



Space Geodesy Satellite Laser Ranging

SGSLR

Critical Design Review

Jan McGarry, 61A
Howard Donovan, 61A/KBRwyle

September 5 & 6, 2018
Version 2.8



Welcome & Logistics



- ◆ Linda opening remarks
- ◆ SGSLR schedule (Jan):
 - Day 1: 8:30am to 5pm (Building 36, room C211)
 - Lunch is on your own – 1 hour.
 - Day 2: 8:30am to noon (Building 21, room 183A)
- ◆ Logistics (Jan):
 - Please sign in the attendance sheets
 - RFAs: Use RFA sheets to fill out (or electronic versions). Please return to Linda.
 - Lunch, breaks, snacks, etc



SGSLR CDR Agenda (1 of 2)



CDR Section	DAY 1 – 36/C211	Time
Opening remarks	Linda Pacini, Jan McGarry	0830
SGSLR Intro/Overview	Jan McGarry	0900
Error budgets	Evan Hoffman, Jan McGarry, Mark Shappirio	1000
	BREAK	1020
Performance Analysis	Jan McGarry	1030
SGSLR Design Overview	Joe Marzouk, Bud Donovan	1130
	LUNCH	1200
Subsystem Designs: Gimbal & Telescope, Time & Frequency, Optical Bench, Meteorological	Bud Donovan	1300
	BREAK	1350
Subsystem Designs: Laser Safety, Laser, Dome/Shelter/Pier/Riser	Bud Donovan	1400
Subsystem Designs: Receiver Subsystem	Evan Hoffman	1440



SGSLR CDR Agenda (2 of 2)



CDR Section	DAY 1 – 36/C211 (cont)	Time
Computer & Software Subsystem	Jack Cheek	1510
System Integration & Testing	Mark Shappirio	1540
Requirements Verification	Mark Shappirio	1620
CDR Section	DAY 2 – 21/183A	Time
Local Operations	Jan McGarry	0830
Site Descriptions	Jan McGarry	0900
Network Architecture	Einar Gautun, Mike Kozlowski	0920
	BREAK	0950
Safety	Josh Allen (10), Bud Donovan(40), Burke Fort(15), Are Færøvig(15)	1000
CM, QA, Path to PSR, Schedule, Risks	Scott Wetzel, Jan McGarry	1120
Summary	Jan McGarry	1150
Concluding Remarks	Linda Pacini	1200



Introduction / Overview



SGSLR CDR Scope (1 of 2)



- ◆ The CDR will concentrate on the ranging performance (ranging data is our critical data measurement)
- ◆ We presented the detailed design information at the EPRs and will not go into as much detail in the CDR
- ◆ We will present the design, development and testing through Collocation and Pre-Ship Review (PSR) for the following systems:
 - McDonald Geophysical Observatory (MGO)
 - Ny-Ålesund Geophysical Observatory (NGO)
- ◆ We will cover the Integration & Testing at the Goddard Geophysical and Astronomical Observatory (GGAO) site



SGSLR CDR Scope (2 of 2)



- ◆ The CDR covers local operations of SGSLR only
 - SGSLR will be operated locally through collocation and commissioning
 - Development of remote operations will continue throughout this period, but a local operator will always be present
- ◆ Safety for MGO and NGO will be presented by the site owners
- ◆ The software is classification “D” during this phase
 - The software does not control or make any safety decisions.
 - Safety decisions are made by the hardware and the local operator

SGSLR is a ground instrument, not subject to the full rigor of the NASA design, build or review process. The SGSLR team is small with limited funding. We are concentrating now on meeting the performance requirements and getting the technical details right.



What we will show



- ◆ We have made major progress in the SGSLR subsystem designs:
 - Some subsystems are being built (for long lead time builds and based on successful EPRs)
 - Others are at the threshold of being built
- ◆ The design meets the performance requirements
- ◆ Safety is an important part of our process
- ◆ Facilities are in place to support the build and testing
- ◆ We are ready to continue with the subsystem builds (after completing the final subsystem technical reviews)



Success Criteria Tailored (NPR 7123.1B) (1 of 2)



- ◆ The detailed design is expected to meet the requirements with adequate margins.
- ◆ Interface control documents are sufficiently mature to proceed with fabrication, assembly, integration, and test, and plans are in place to manage any open items.
- ◆ High confidence exists in the product baseline, and adequate documentation exists or will exist in a timely manner to allow proceeding with fabrication, assembly, integration, and test.
- ◆ The product verification requirements and plans will be completed in a timely manner.
- ◆ The testing approach is well understood, and the planning for system assembly, integration, test, and site commissioning and operations is sufficient to progress into the next phase.
- ◆ Risks to mission success are understood and credibly assessed, and plans exist to manage them.
- ◆ Safety and reliability have been adequately addressed in system and operational designs, and any applicable safety and reliability products meet requirements, are at the appropriate maturity level for this phase of the program's life cycle, and indicate that the program safety/reliability residual risks will be at an acceptable level.



Success Criteria Tailored (NPR 7123.1B) (2 of 2)



- ◆ The project has demonstrated compliance with NASA requirements, standards, processes, and procedures for IT Security and Safety.
- ◆ There are no TBD and TBR items in the level 3 and 4 requirements.
- ◆ Engineering test units and modeling and simulations have been developed and have been or are being tested per plan.
- ◆ The operational concept has matured, is of sufficient detail, and has been considered in test planning.
- ◆ Manufacturability has been adequately included in design (and presented in more detail at EPRs).
- ◆ Software design has matured significantly since PDR. The software is ready to progress to next phase. And continued development during this next phase will produce mature design, hazard analysis, and testing process.



NASA's Space Geodesy Program (SGP)



- ◆ New NASA initiative started at the end of 2011 in response to the Earth Science Decadal and the National Research Council study “Precise Geodetic Infrastructure.”
- ◆ Encompasses the development, operation, and maintenance of a Global Network of Space Geodetic technique instruments, a data transport and collection system, analysis and the public disseminations of data products required to maintain a stable terrestrial reference system.
- ◆ Comprises ongoing tasks that include:
 - The operation and management of NASA’s existing global geodetic network and analysis systems, and the delivery of Space Geodetic products.
 - Operation of the prototype next generation space geodetic site at NASA Goddard with integrated next generation SLR, VLBI, GNSS, and DORIS stations, along with a system that provides for accurate vector ties between them.
 - **Plan and implement the construction, deployment and operation of a NASA network of similar next generation stations that will become the core of a larger global network of modern space geodetic stations.**
 - Development and delivery of retro-reflector arrays for the next generation GPS III satellites.
 - Modernization of NASA’s space geodesy analysis systems in support of NASA Earth Science requirements.

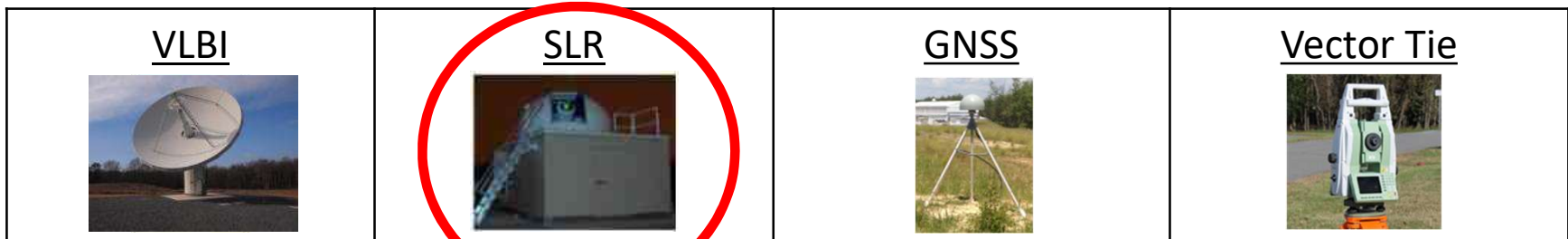



NASA's Space Geodesy Partners



- ◆ The McDonald Observatory has been part of the NASA's Satellite Laser Ranging for over 50 years. Now a partner for Space Geodesy's VLBI as well as SLR. The SGP site is called McDonald Geophysical Observatory (MGO).
 - The development of the MGO site for SLR and VLBI is a partnership between the University of Texas and SGP.
 - Operation of the two stations will be under an existing contract with UT.
- ◆ Ny-Ålesund has long been a VLBI site and the partnership between NASA and Norway's Kartverket (aka Norwegian Mapping Authority or NMA) is longstanding. The new site at Ny-Ålesund has 2 new VLBI stations and will house SGSLR. This site is NGO.
 - NMA has developed the new site & built the shelter.
 - NASA is building the SGSLR system for NMA under a Reimbursable Agreement.



SGP Project Organization

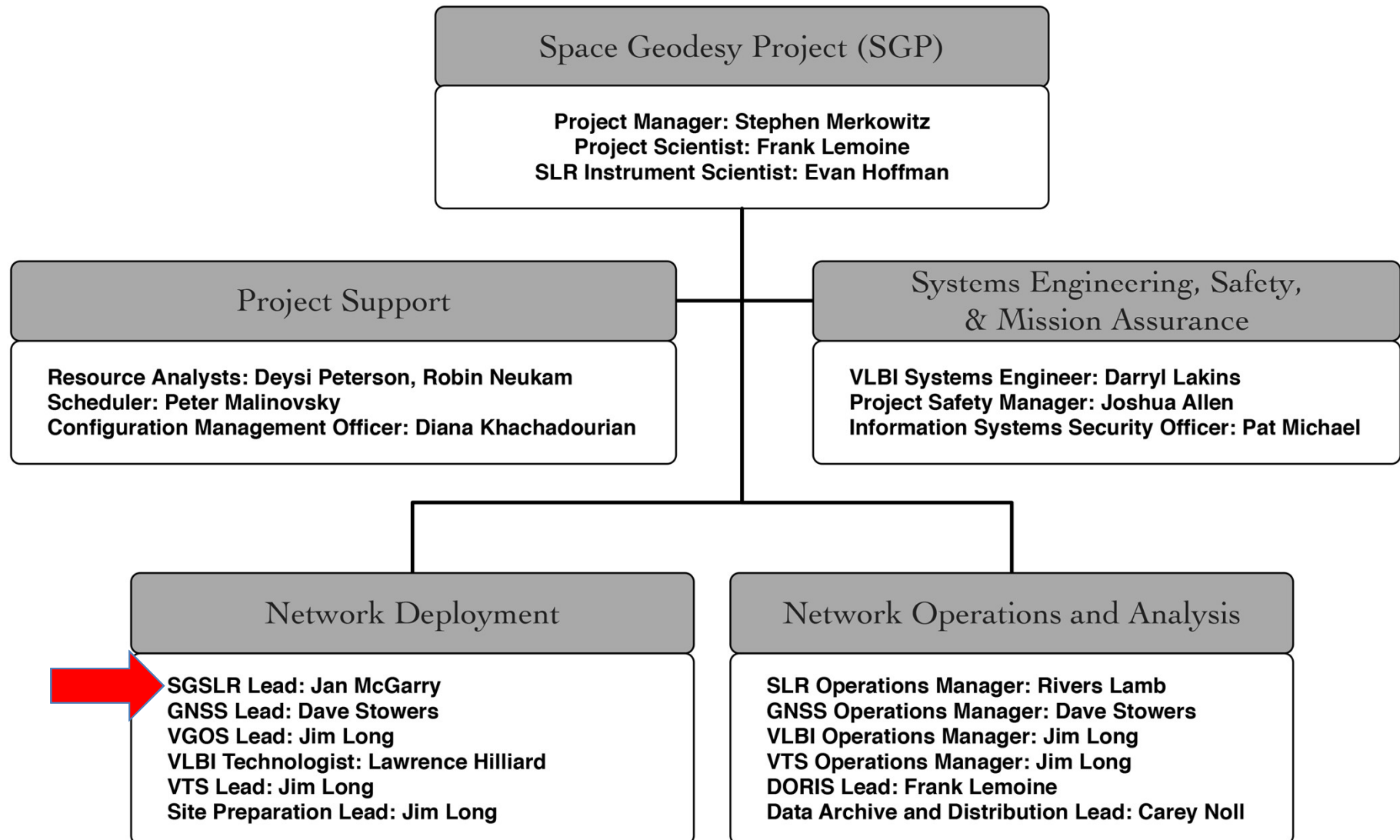



SGSLR Organization (1 of 2)

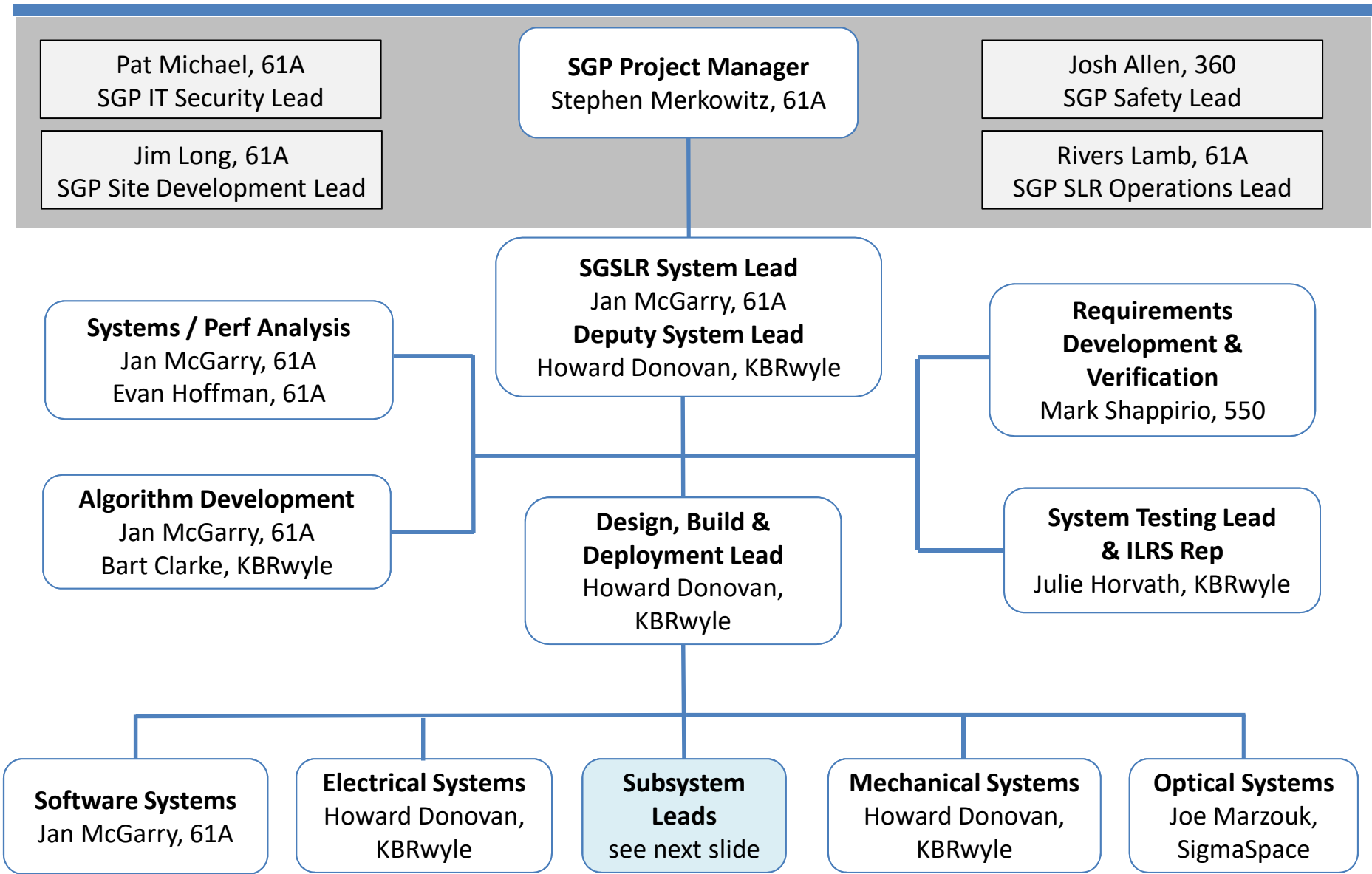



SGSLR Organization (2 of 2)

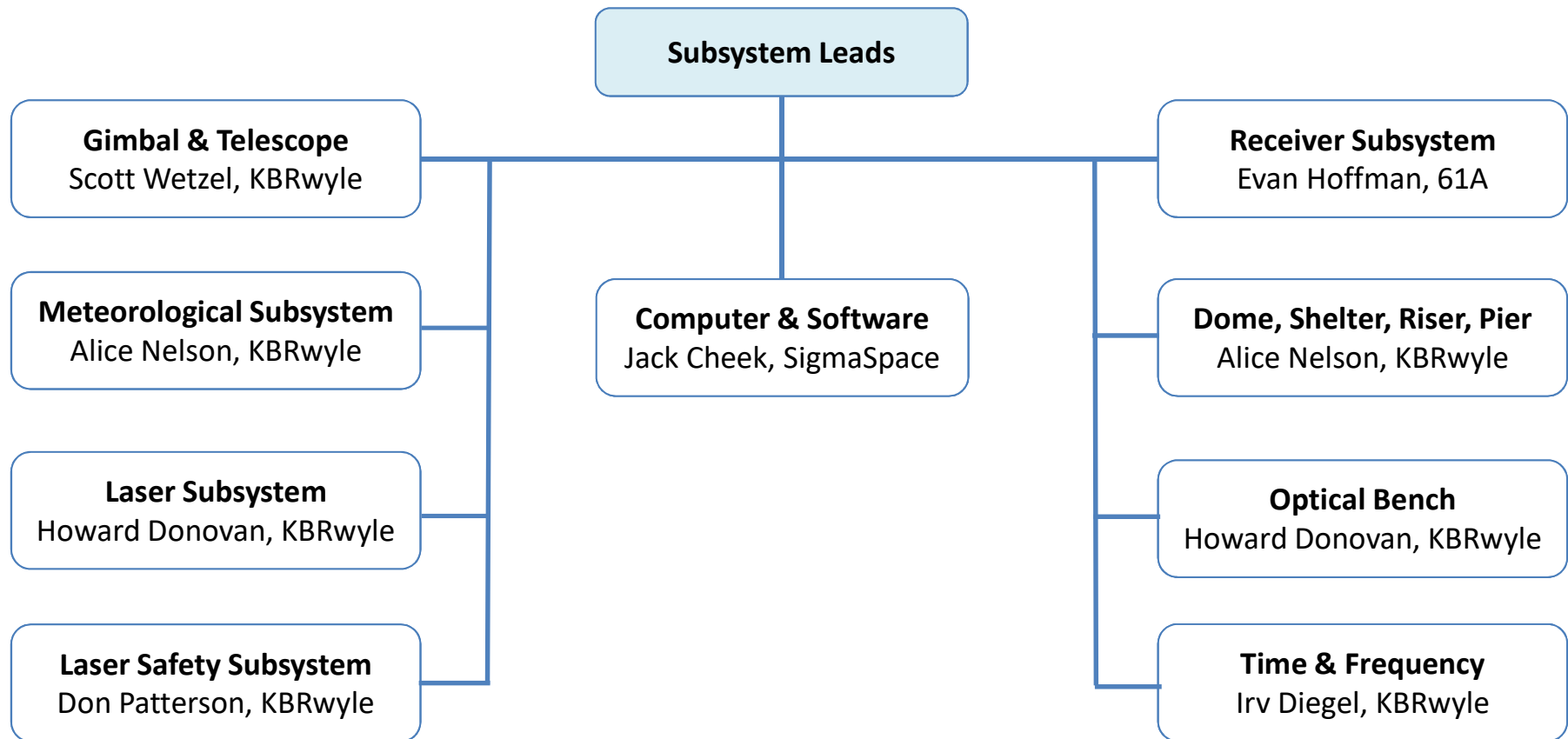

SGSLR Team is made up of < 20 FTEs (including C.S. and contractor)



SGSLR Simplified Block Diagram

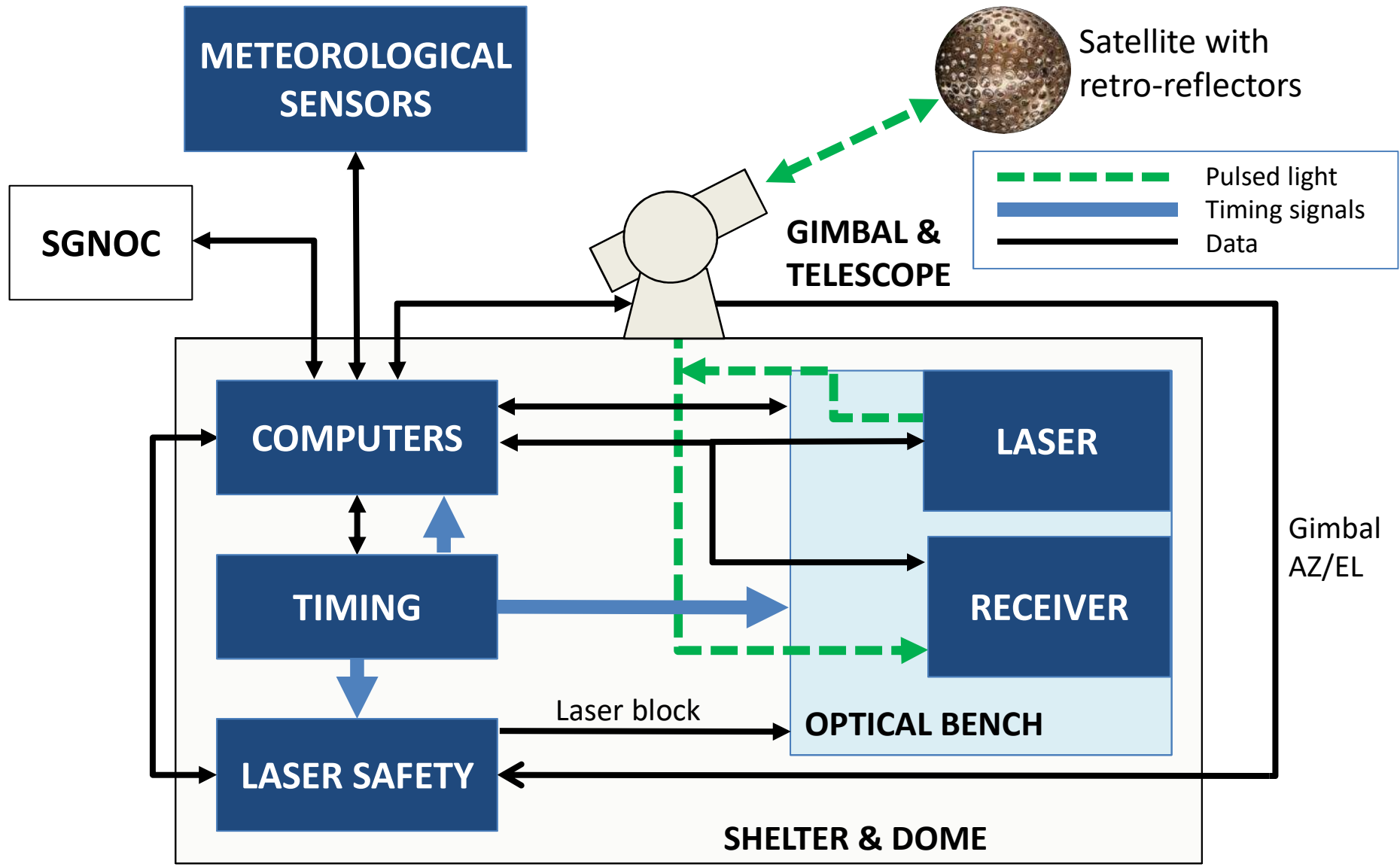



SGSLR's Nine Major Subsystems



- **Timing & Frequency (T&F)**
 - GPS tie to USNO – heart beat of system
 - Monitoring of timing using 2nd GPS
 - Monitoring info supplied to software
- **Meteorological (MET)**
 - Pressure, Temperature, Humidity for data quality
 - Horizontal Visibility, Precipitation, Wind, Sky Clarity for automation
- **Telescope and Gimbal**
 - Gimbal & Telescope Assembly (**GTA**) – pointing and tracking
 - Visual Tracking Aid – used by operator
- **Optical Bench (OB)**
 - Transmit path, Receive path, Star Camera, Motion Control
 - Software can automatically configure for all modes
- **Laser**
 - Provides health & diagnostic information to Software
 - Repetition rate controlled by software
- **Laser Safety (LSS)**
 - NASA/ANSI compliant, Failsafe, Redundant, Highly responsive
 - Provides information to Software on actions it takes and reasons why
- **Receiver**
 - Sigma Space Range Receiver (**SSRx**) – Precise signal timing coupled with angular offset info to optimize pointing
 - Range Control Electronics (**RCE**) – sets range window and laser fire rate
- **Dome, Shelter, Pier, Riser (DSPR)**
 - Provides clean stable environment and protection from weather
 - Software controls power through UPS units and can shut everything down
- **Computer and Software (C&S)**
 - Ties all subsystems together for manned, remote, and automated operations



SGSLR Facilities at GSFC



- ◆ Building 28 W120G
 - Limited access lab (smartcard needed) with no windows
 - Designed for laser testing & characterization
 - Optical benches will be built here
- ◆ 1.2 meter telescope facility (located at GGAO)
 - Hardware lab is being used for receiver testing
 - Telescope can and has been used for:
 - Ground target ranging using SGSLR prototype receiver
 - Testing GTA FAT camera configuration by tracking stars and sunlit satellites
 - Software lab is being used for SW development/testing
- ◆ SGSLR facility (located at GGAO)
 - Ground breaking for this facility will be soon (code 220)
 - Will be used for GTA SAT, SGSLR I&T, and System Verification (including collocation with MOBLAS-7)



SGSLR External Interfaces

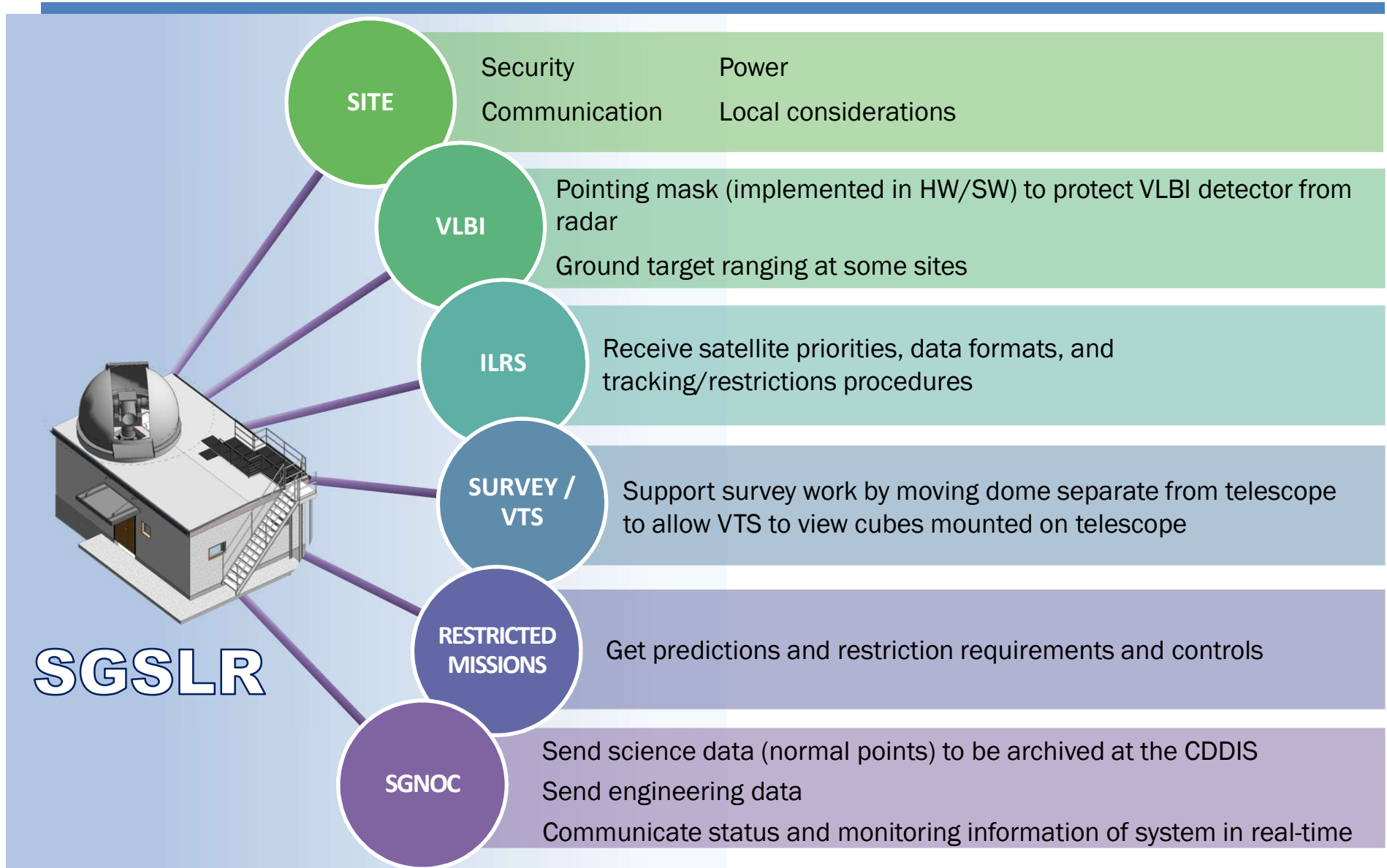



International Laser Ranging Service: Goals



- ◆ To provide global satellite and lunar laser ranging data and their related products to support geodetic and geophysical research activities.
- ◆ To promote research and development activities in all aspects of the satellite and lunar laser ranging technique.
- ◆ To provide the International Earth Rotation and Reference Systems Service (IERS) with products important to the maintenance of an accurate ITRF.
- ◆ To develop the global standards and specifications and encourage international adherence to its conventions.
- ◆ To specify laser ranging satellite priorities and tracking strategies required to maximize network efficiency.
- ◆ To provide a forum for the exchange of laser ranging technology, operational experience, and mission planning.

NASA SLR is a leader in the ILRS





International Laser Ranging Service

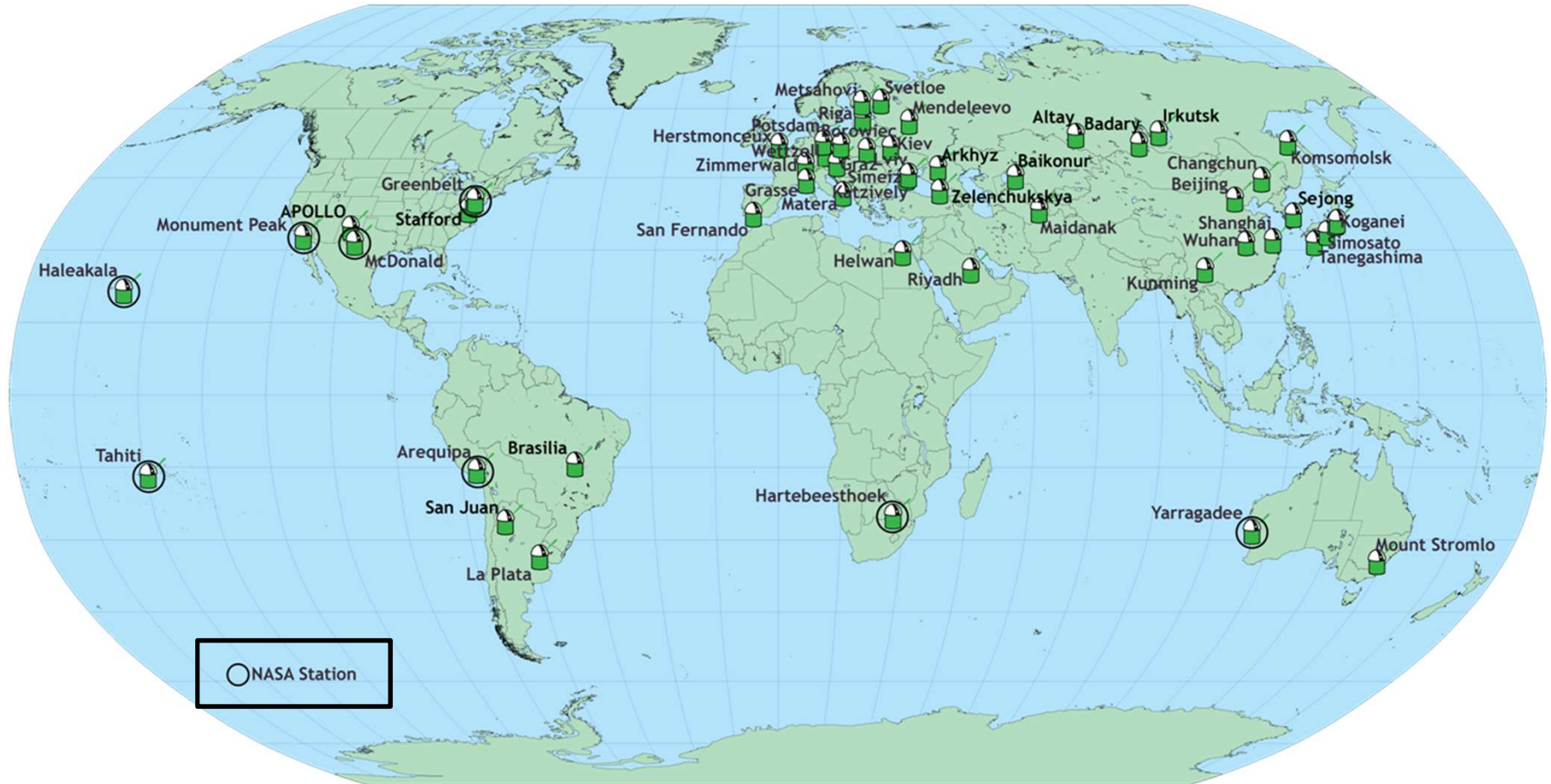

Eight of these stations are part of NASA's Current Legacy Network



Science Data Products



- ◆ Normal Point data is the standard ILRS data product and the primary science data product (level-1). A Normal Point is a combination of range measurements spanning a period of time which is a function of satellite altitude.
- ◆ SGSLR will follow the ILRS standards for Normal Point generation utilizing the Herstmonceux Algorithm. Refer to the following link for a description:
http://ilrs.gsfc.nasa.gov/data_and_products/data/npt/npt_algorithm.html
- ◆ Normal Points will be automatically generated and subject to the following quality control checks on-site.
 - Use a minimum number of observations and single shot RMS to filter potential invalid normal points.
 - Use the skew and kurtosis to filter anomalous normal points.
- ◆ Qualified Normal Points will be automatically delivered to the SGNOC.
- ◆ Full rate data will also be delivered to the SGNOC



ILRS Performance Standards



- ◆ The ILRS uses the LAser GEOdynamics Satellites (LAGEOS) to determine ground system performance

https://ilrs.cddis.eosdis.nasa.gov/missions/satellite_missions/current_missions/lag1_general.html

- ◆ LAGEOS satellites (1 and 2) are spherical satellites with 426 retro-reflector cubes uniformly distributed about the surface
- ◆ Very stable ~6000 km altitude orbits
- ◆ Satellite ephemeris is known to < 1 cm
- ◆ 40+ years on orbit for first LAGEOS





SGP Requirements



- ◆ Level 0: Project Objectives
- ◆ Level 1: Science Requirements
- ◆ Level 2: Mission Requirements
- ◆ **Level 3: Technique Requirements (SLR, VLBI, etc.)**
- ◆ **Level 4: Subsystem Requirements**
- ◆ Level 5: Component Requirements

**This review covers SGP Requirements
Levels 3 and 4 for SGSLR**



Quality Requirements

- **SLBP3.1**
Data precision for LAGEOS Normal Points shall be < 1.5 mm when averaged over a one month period
- **SLBP3.2**
The LAGEOS Normal Point range bias shall be stable to 1.5 mm over 1 hour
- **SLBP3.3**
Over 1 year the RMS of station's LAGEOS Normal Point range biases shall be < 2 mm
- **SLBP3.5**
Normal Point time of day shall be accurate to < 100 ns RMS
- **SLBP3.8**
SGSLR Stations shall not introduce any unquantified biases into the legacy SLR network

Quantity Requirements

- **SLBP3.4**
SGSLR Station shall be capable of producing an annual volume of 45,000 LEO, 7,000 LAGEOS and 10,000 GNSS Normal Points



SGSLR Documents



- ◆ SGSLR produced; signature controlled at SGP level
 - Document Tree (SGP-SGSLR-DESC-0006)
 - Development & Implementation Plan (SGP-SGSLR-PLAN-0016)
 - Ny-Ålesund Concept of Operations (SGP-SGSLR-PLAN-0012)
 - McDonald Concept of Operations (SGP-SGSLR-PLAN-0013)
 - External Interface Document (SGP-SGSLR-ICD-0001)

- ◆ SGSLR produced; signature controlled at SGSLR level
 - Systems Requirements Level 4 (SGP-SGSLR-REQ-0001)
 - Test and Verification Plan (SGP-SGSLR-PLAN-0014)
 - Internal Interface Document (SGP-SGSLR-ICD-0004)
 - Hardware Design Document (SGP-SGSLR-DESC-0004)
 - Software Design Document (SGP-SGSLR-DESC-0005)

Documents can be found on the SGP TDMS site



Changes since PDR



- ◆ All subsystem designs have matured.
 - EPRs were part of the maturing process.
- ◆ Receiver: MCP PMT array instead of SiAPD (SensL).
- ◆ Software now using VMs for some computers as suggested by panel at PDR.
- ◆ IT Security and Network Architecture designed to meet NASA requirements.
- ◆ All Sky Camera for local & remote operator has been chosen and has gone through initial testing.



PDR RFAs



- ◆ There were 36 RFA's.
- ◆ We have responded to 32, of which 7 have been closed.
- ◆ All PDR RFAs and responses are in the files given to panel.
- ◆ PDR RFAs were a useful part in the maturing process of the subsystem designs.
- ◆ And there are 4 that we cannot yet respond to. These are explained on the next slide.



PDR RFAs not yet responded to



RFA #	Originator	RFA description	Reason why we cannot respond
13	J. Volosin	The team should perform a thorough assessment of the plans for SGSLR automation prior to CDR.	1
24	L. Thomas	Complete a formal receiver trade study.	2
30	X. Sun	Develop two (or three) levels of autonomous rules, one with high reliability and completely autonomous.	1
32	X. Sun	Complete the software development of the cloud detection via the IR camera.	3

- 1- We will be doing a post-CDR review (~ 1 year) on Remote and Automated Operations and will present these analyses and plans there.
- 2- We are still working on this. Expect to have this completed in next few months.
- 3- We will be developing the cloud detection algorithms ourselves. This will not be needed until Full Automation. A preliminary report on our progress will be given at the Remote & Automated Operations Review.



Subsystem EPRs: Dates/Leads



- ◆ GTA: April 2015 (Donovan/Marzouk lead) **COMPLETED**
- ◆ Laser: June 2016 (Hoffman lead) **COMPLETED**
- ◆ Timing: June 2016 (Diegel lead) **COMPLETED**
- ◆ MET: June 2016 (Nelson lead) **COMPLETED**
- ◆ RCE: Nov 2016 (Donovan/Patterson leads) **COMPLETED**
- ◆ DSPR: Feb 2017 (Donovan/Nelson leads) **COMPLETED**
- ◆ OB: March 2018 (Donovan lead) **COMPLETED**

Receiver, Laser Safety and Software: reviews expected to be completed by early 2019.

All review packages can be found on the SGP TDMS site



Subsystem EPRs: Panel / RFAs



- ◆ GTA: 7 RFAs (**ALL CLOSED**)
 - Panel: S. Merkwowitz, L. Ramos-Izquierdo, J. Griffiths (NRL), C. Moore (NRL), J. Livas, J. Esper
- ◆ Laser, Timing, MET: 3 RFAs (**ALL CLOSED**)
 - Panel: S. Merkwowitz, X. Sun, M. Stephen, L. Hilliard
- ◆ RCE: 2 RFAs (**ALL CLOSED**)
 - Panel: S. Merkwowitz, D. McCormick, J. Degnan
- ◆ DSPR: 8 RFAs (**ALL CLOSED**)
 - Panel: S. Merkwowitz, J. Long, T. Sanders, T. Hayes, D. McCormick, R. Smallcomb, M. Perry.
- ◆ OB: 11 RFAs (**ALL CLOSED**)
 - Panel: S. Merkwowitz, L. Ramos-Izquierdo, X. Sun, C. Moore (NRL).

Responses to all EPR RFAs can be found on the SGP TDMS site



Following the path from Light to Range Data



Ranging Data Flow: Real-time SW & HW

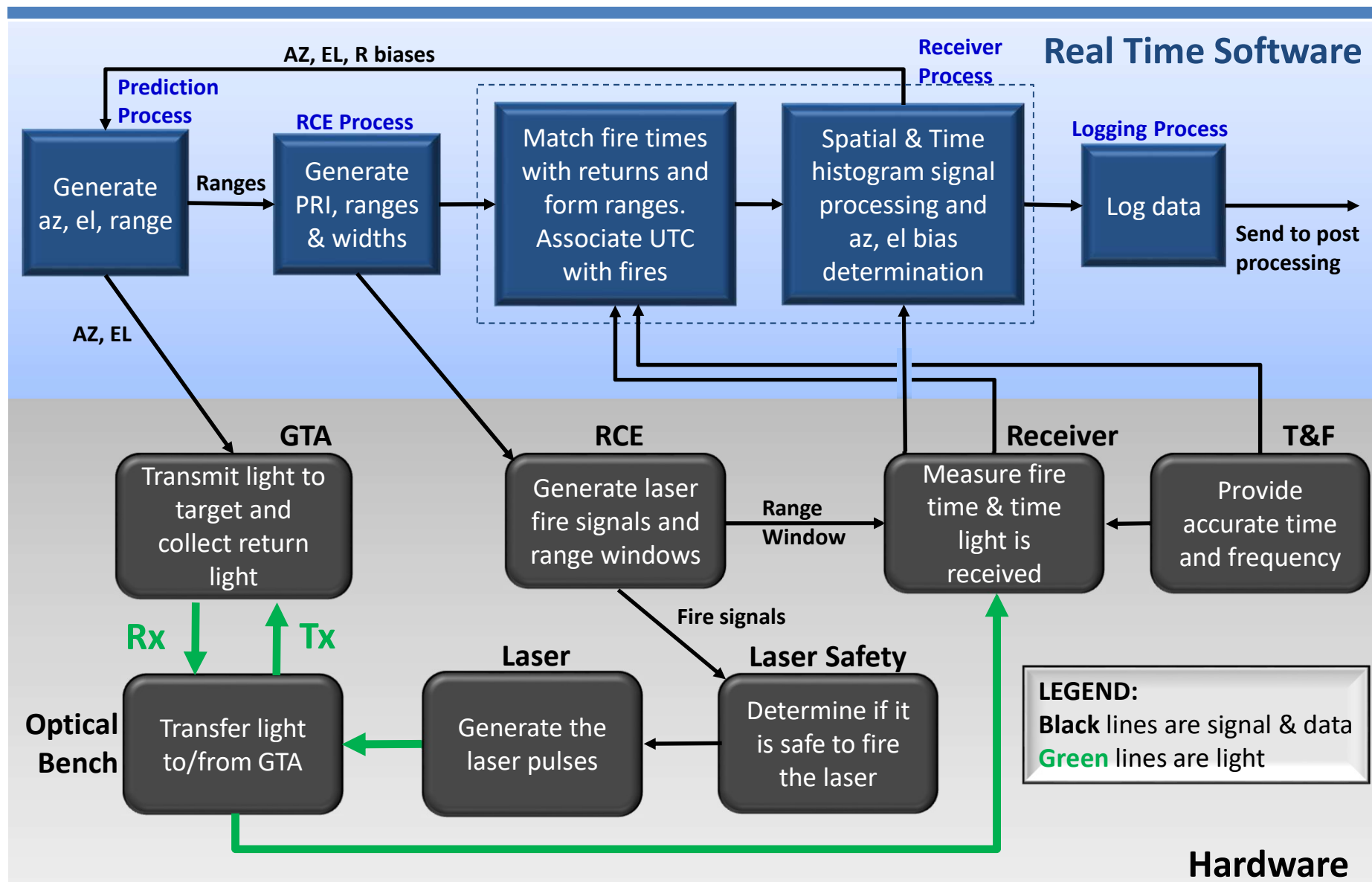



Range Control Electronics (RCE) Process



The RCE process generates fire times, ranges and range widths for RCE. The process adjusts the pulse repetition interval (PRI) so that there are no collision between fire and return in a 2 kHz interval.

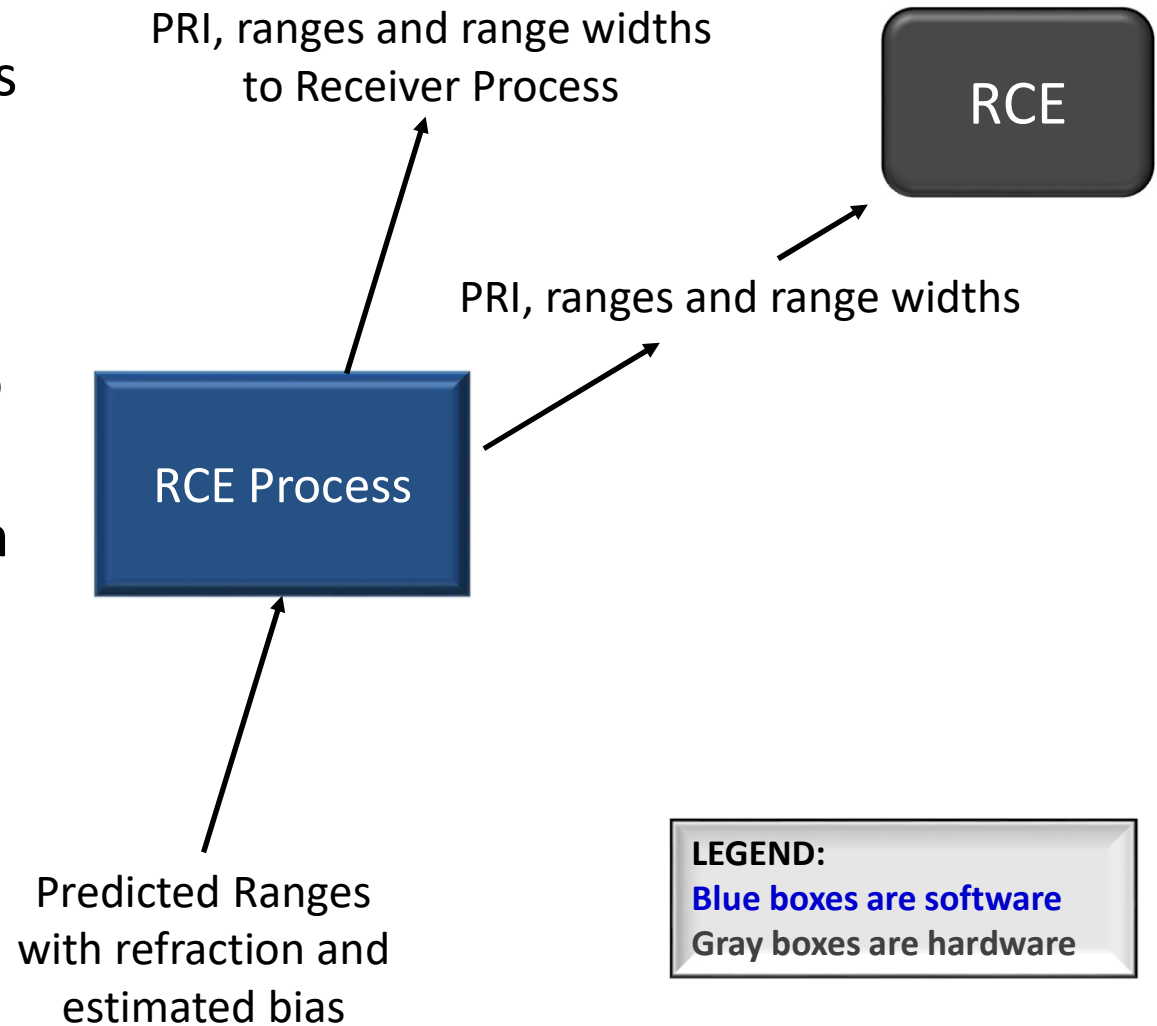



Receiver Process



The Receiver Process receives event timer stop, start, and 1 PPS event bundles. Then it:

- ◆ Generates relative event times from event timer coarse and fine counts
- ◆ Determines epoch fire times from IRIG-B, 1 PPS and event time 1 PPS
- ◆ Determines ranges by matching event timer fires and returns
- ◆ Signal Processes spatial data to estimate angular bias

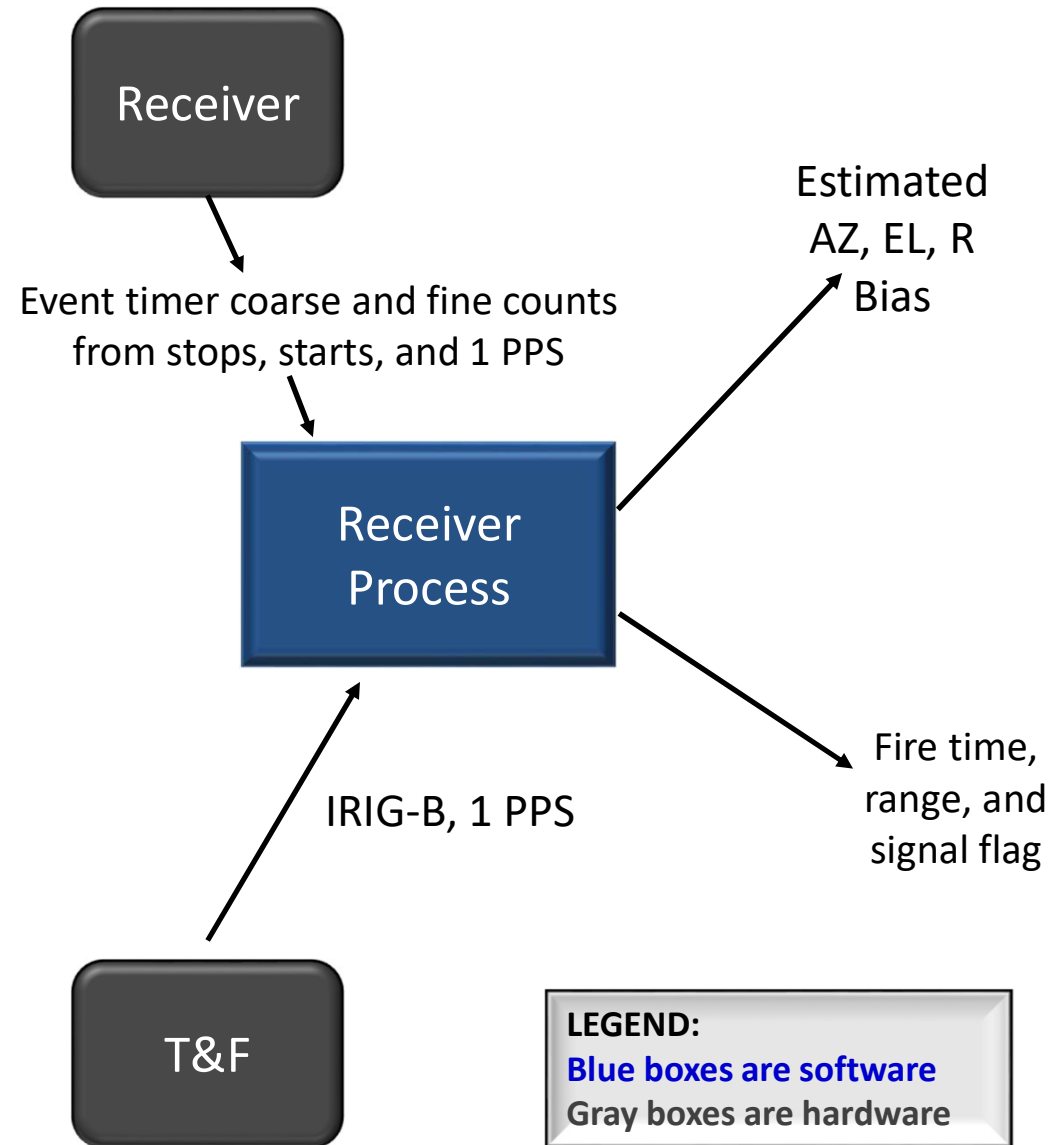



Calculations for Range Determination



◆ Relative Event Timer Times

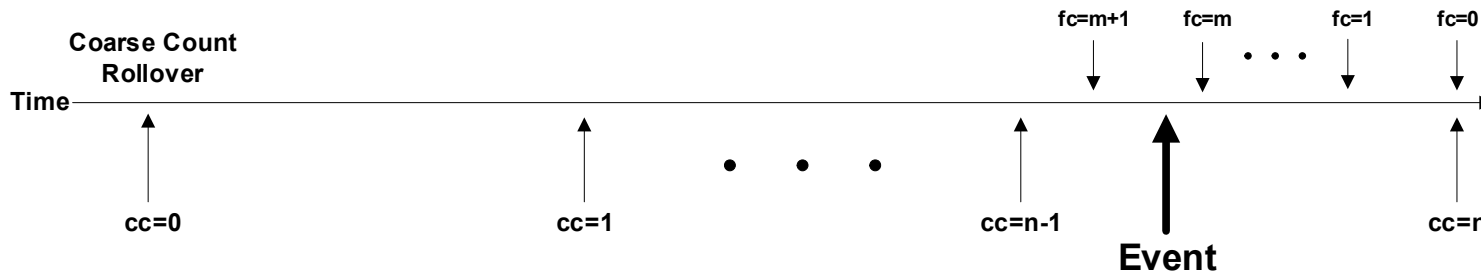

cc = event timer coarse count
fc = event timer fine count

$$ET = (cc / cc_{\text{rate}}) - f(fc),$$

ET = time of event since last event timer coarse count rollover (relative count)

where $f(fc)$ is determined from a fine calibration table and cc_{rate} is the coarse count rate



Calculations for Range Determination (cont.)



◆ Fire Time and Range

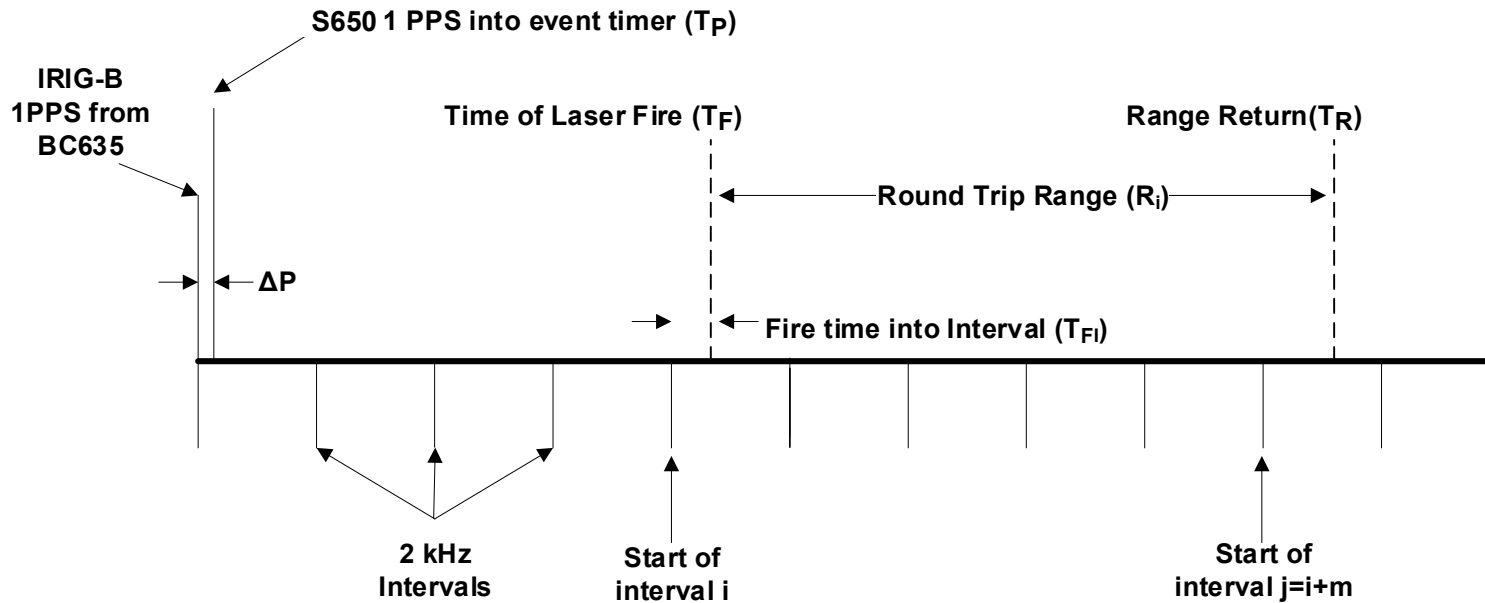

$$T_F = \text{SOD} + (ET_F - ET_{1\text{PPS}}) - \Delta P$$

$$R_i = (ET_R - ET_F)$$

where,

SOD = second of day from IRIG-B 1 PPS

ET_F = relative ET time of fire

$ET_{1\text{PPS}}$ = relative ET time of 1 PPS into ET

ΔP = known offset between BC635 and ET 1 PPS

ET_R = relative ET time of return



Post Processing Data Flow



- ◆ When a ground calibration is processed, satellite data between that calibration and the previous calibration are processed (~45 to 90 minutes between calibrations). Calibrations are used to determine system delay.
- ◆ When forming normal points, the full rate data are corrected for the system delay determined from the pre and post calibration and a refraction correction determined from the meteorological parameters.
 - The system delay is applied to the normal point.
 - Per ILRS standards, the refraction correction is not applied to the normal point, but is included in the data record.
- ◆ When processing is complete, the normal points and potentially the full rate data are transferred to the SGNOC for use by science community. This data is used by the scientific community for the generation of the ITRF and precision orbits.

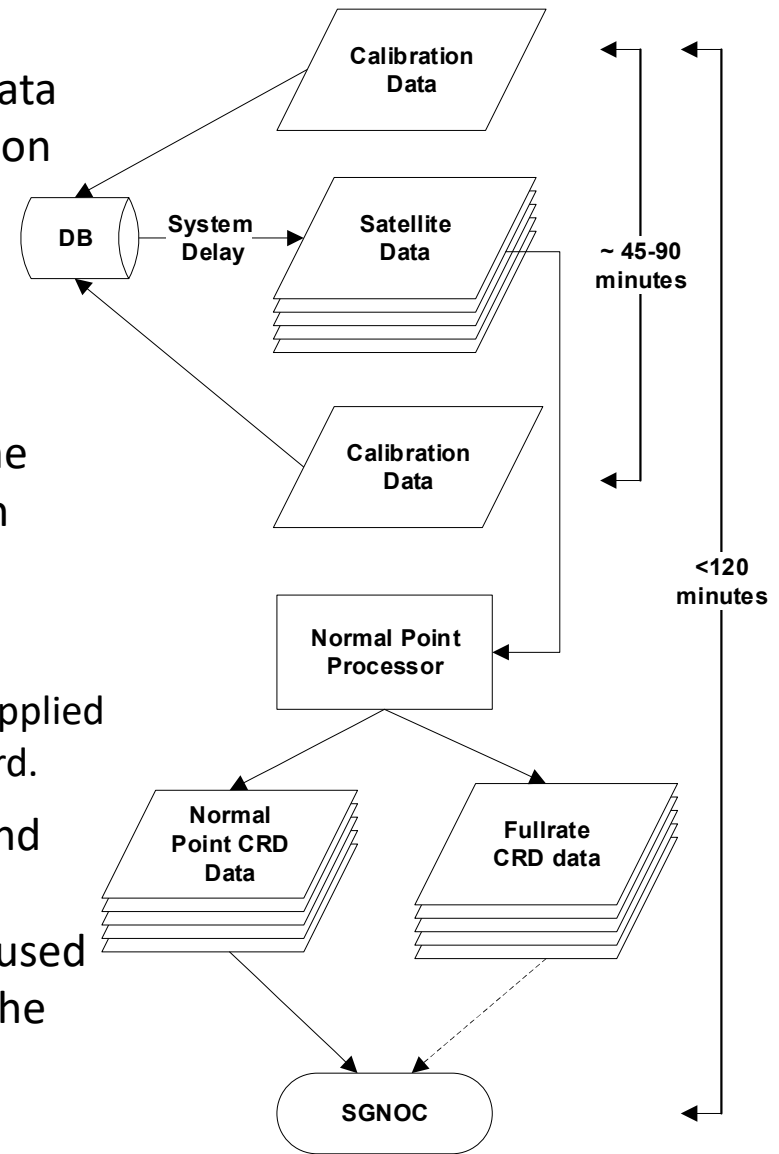



Error Budgets



LAGEOS Annual Bias Error Budget

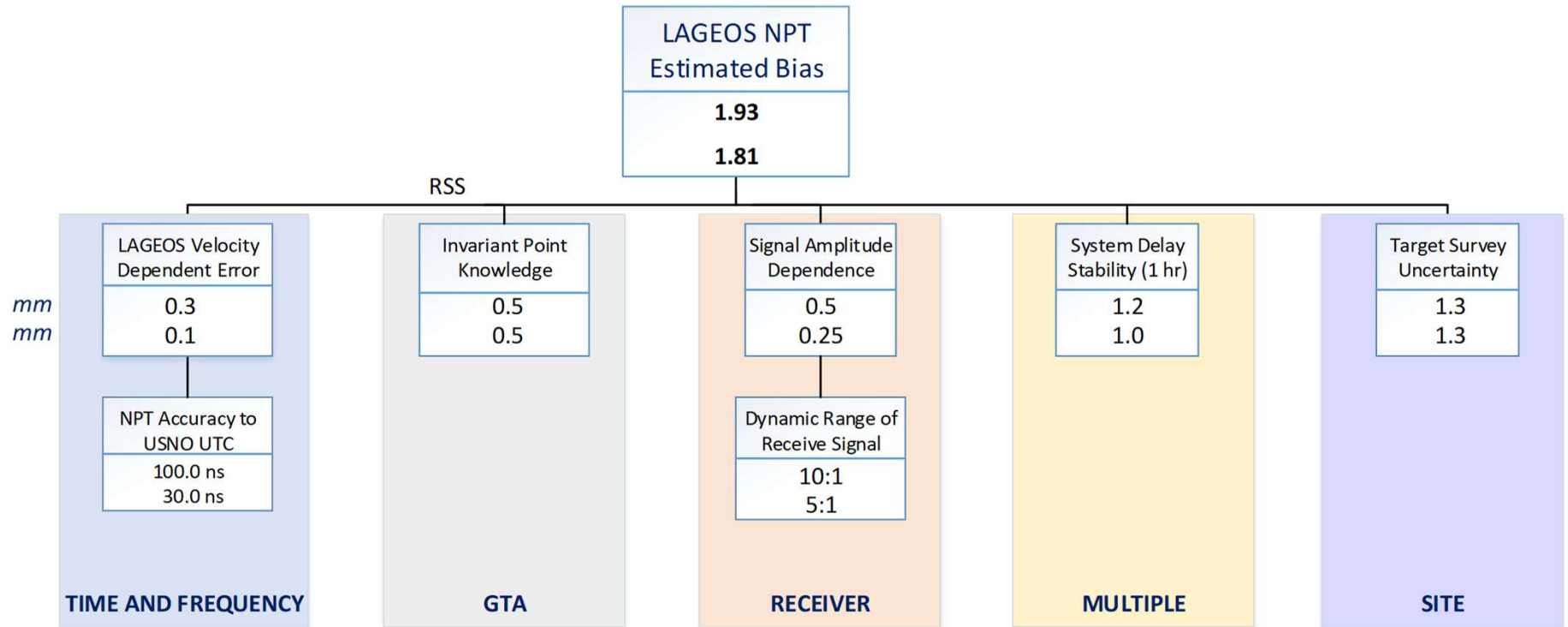

Requirement SLBP3.3: Less than 2 mm over the course of a year

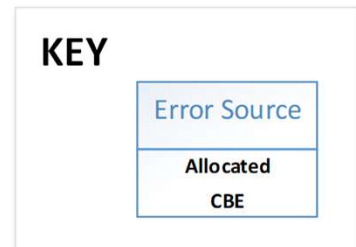



Precision Error Budget

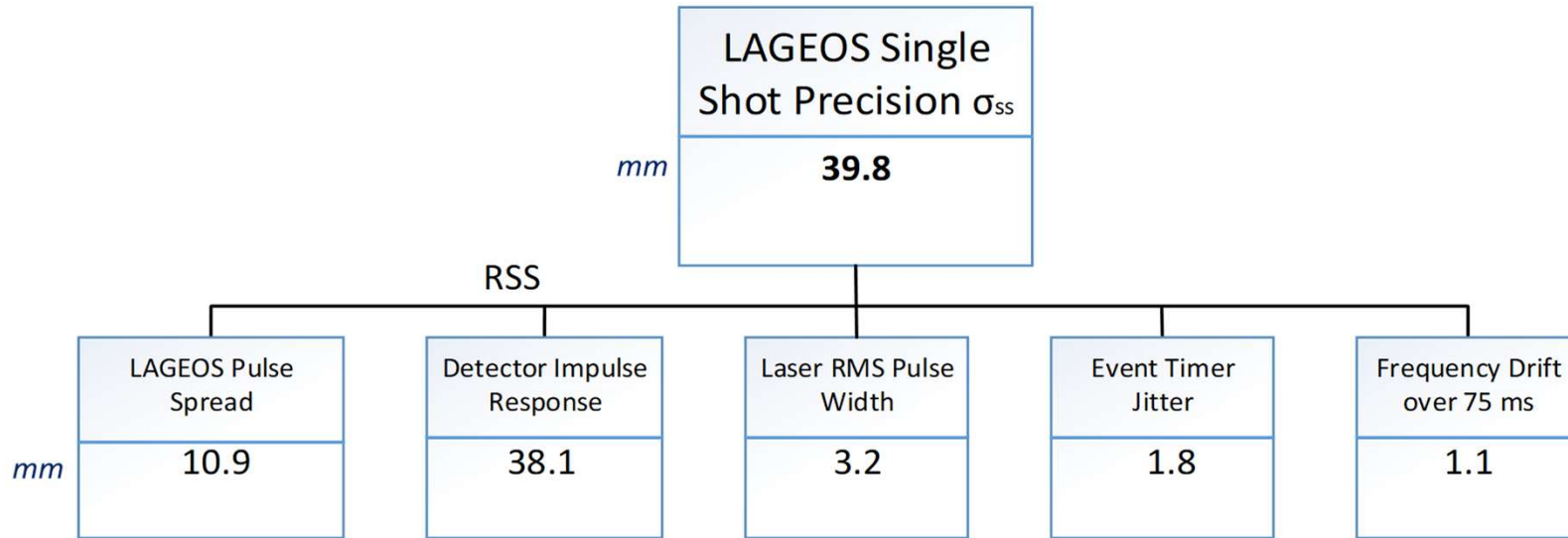

Single Shot Precision σ_{SS}

Normal Point Precision σ_{NPT}

Number of Observations N

$$\sigma_{NPT} = \frac{\sigma_{SS}}{\sqrt{N}} = 1 \text{ mm} \Rightarrow N = 1586 \Rightarrow \frac{N}{2000 \text{ Hz} * 10\% \text{ return rate}} = 7.9 \text{ seconds}$$

A normal point for LAGEOS must be acquired within a **2 minute** time bin





Normal Point Time Tag Error

Error Budget Contributions – Normal Point Time of Day



➤ **SLBP3.5** Normal Point time of day shall be accurate to < 100 ns RMS

	Allocation (ns)	CBE (ns)	Subsystem
S650 1 PPS error to USNO	99.960 RMS	15.000 RMS	Timing
1 PPS Splitter Jitter	0.100 RMS	0.010 RMS	Timing
Distribution Amplifier Jitter	0.100 RMS	0.050 RMS	Timing
1 PPS delay to receiver meas. error	2.000 RMS	0.500 RMS	Timing
1 PPS delay within ET meas. error	2.000 RMS	0.500 RMS	Receiver
1 PPS ET measurement error	0.200 RMS	0.004 RMS	Receiver
Start diode fire time error	0.100 RMS	0.010 RMS	Receiver
Fire time ET measurement error	0.200 RMS	0.004 RMS	Receiver
Software induced 1PPS error	0.010 RMS	0.000 RMS	Software
Software induced fire time error	0.010 RMS	0.005 RMS	Software
Normal Pt time calculation error	0.010 RMS	0.005 RMS	Software
TOTAL error	~ 100 ns RMS	~ 15.02 ns RMS	
T&F Contribution to error	~ 99.98 ns RMS	~ 15.01 ns RMS	

(RSS of all RMS values)



Tracking Pointing Error



	Allocation (asec)	CBE (asec)	Subsystem
SUM of GTA errors	2.0 RMS	1.5 RMS	GTA
Gimbal command minus encoder	1.0 RMS	1.0 RMS	GTA
GTA SDC timing induced errors	1.0 RMS	0.5 RMS	GTA
Pointing offset measurement error	2.0 RMS	1.0 RMS	Receiver
Calculation error and error caused by delay in applying offset	2.0 RMS	1.0 RMS	Software
TOTAL error (RSS)	3.5 asec RMS	2.1 asec RMS	

No mount model error assumed here because of closed loop tracking provided by receiver subsystem

Pointing Error impacts the link which directly affects the data volume requirement (SLBP3.4)



Acquisition Pointing Error



	Allocation (asec)	CBE (asec)	Subsystem
Gimbal errors (RMS)	2.0	1.5	GTA
Mount model error (RMS)	3.0	3.0	GTA
Satellite prediction error: LEO, LAGEOS, GNSS (RMS)	6.0, 2.0, 1.0	5.5, 1.0, 0.5	Software
TOTAL error (RSS): LEO, LAGEOS, GNSS (RMS)	7.0, 4.1, 3.7	6.4, 3.5, 3.4	

This error calculation is for regularly tracked ILRS satellites with good predictions and known or very small timebias errors. Time bias error assumed to be 5 ms or less.

Acquisition Pointing Error impacts the link and thus the time to acquire which directly affects the data volume requirement (SLBP3.4)



Target Acq Budget: Time to close on Target



LEO, LAGEOS, GNSS worst case	Allocation (sec)	CBE (sec)	Subsystem
Time to slew to target (max 180°)	20	9	GTA & Dome
Time to settle once at target	5	3	GTA
Time to acquire (open loop pt)	30	20	Software & Rcvr
Time to make final pt correction	5	1	Software & GTA
TOTAL allocation error (SUM)	60 sec	33 sec	

This calculation is not an error budget but rather a determination of the maximum time that would be required to find the target, center it in the FOV, and transfer to Tracking mode for a satellite with good predictions and with hazy sky conditions.

Time to acquire and close on the target impacts the data volume requirement (SLBP3.4)



MTBF/MTTR: Assumptions



- ◆ 16% allotted downtime (~54 days)
- ◆ Summed with weather outages for data volume analysis
- ◆ Subsystem downtime summed (conservative estimates)
- ◆ Components within a subsystem RSS'ed
- ◆ CBE based on vendor data where available, previous use of equipment or comparable equipment when vendor data not available



MTBF/MTTR: Subsystem Allotment and CBE



SUBSYSTEM	Allotment		CBE	
	%	days/yr	%	days/yr
Gimbal and Telescope Assembly	0.7	2.6	0.685	2.5
Optical bench	1.8	6.6	1.754	6.4
Receiver	1.6	5.8	1.574	5.7
Laser	2.9	10.6	2.854	10.4
Laser Safety	2	7.3	1.937	7.1
Time and Frequency	1.3	4.7	1.27	4.6
Meteorological	0.5	1.8	0.412	1.5
Dome, Shelter, Pier and Riser	3.1	11.3	3.051	11.1
Computer and Software	2.1	7.7	2.05	7.5
Total	16	58.4	15.587	56.8



Performance Analysis: Link Calculations



SLR Link Equation

$$n_s = \frac{E_t}{h\nu} \eta_t \frac{2}{\pi(\theta_d R)^2} \exp\left[-2\left(\frac{\Delta\theta_p}{\theta_d}\right)^2\right] \left[\frac{1}{1 + \left(\frac{\Delta\theta_j}{\theta_d}\right)^2} \right] \left(\frac{\sigma A_r}{4\pi R^2} \right) \eta_r \eta_c T_a^2 T_c^2$$

n_s = detected satellite photoelectrons per pulse

E_t = laser pulse energy

$h\nu$ = laser photon energy = 3.73×10^{-19} J @ 532 nm

η_t = transmitter optical throughput efficiency

θ_d = beam divergence half angle

R = slant range between station and satellite

$\Delta\theta_p$ = laser beam pointing error

$\Delta\theta_j$ = RMS tracking mount jitter

σ = satellite optical cross-section

A_r = Telescope Receive Area

η_r = receiver optical throughput efficiency

η_c = detector counting efficiency

T_a = one way atmospheric transmission

T_c = one way cirrus cloud transmission

Reference: J. Degnan, "Millimeter Accuracy Satellite Laser Ranging: A Review", in Contributions of Space Geodesy to Geodynamics: Technology Geodynamics, 25, pp. 133-162, 1993.

Short and Long Term Beam Wander, Scintillation now included in T_a (they were not at PDR)



SLR Characteristics for Link Calculations



Array detector with 7 x 7 elements (pixels) with edges missing

Laser fire rate: 2 kHz

Signal processing frame time is short enough that we don't have to worry about Coudé path rotation

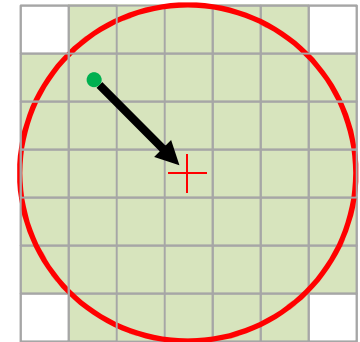

Center of receiver FOV shown with red crosshairs. Target returns offset from center shown as green dot.

Characteristics	SGSLR value
Per pulse laser energy transmitted (out of laser)	1.5 mJ
Optical throughput: transmit	0.77
Optical throughput: receive	0.54
Satellite retro-reflector response	Given at ILRS website
Cirrus cloud contribution	Medium
Effective Receive Aperture	0.187 m ²
Detector counting efficiency	0.28
Beam wander and scintillation	Sea level site (worst case)
Tracking closed loop tracking	7 x 7 pixelated detector



Detection Probability and Normal Point Precision



For a SLR system with a single photon detection threshold, the probability of detecting the satellite signal is

$$P_d = 1 - \exp(-n_s) \cong n_s$$

where the approximation holds for $n_s \ll 1$. In this low signal limit, the number of range measurements contributing to a satellite “normal point” is

$$N = P_d f_L \tau_{np} = (1 - e^{-n_s}) f_L \tau_{np}$$

where

f_L = the laser repetition rate,

τ_{np} = the normal point time interval

and the normal point precision is equal to

$$\sigma_{np} = \frac{\sigma_{ss}}{\sqrt{N}}$$

where σ_{ss} is the satellite-dependent, single shot range precision.



Atmospheric Attenuation



The atmospheric attenuation coefficient decreases approximately exponentially with altitude, h , according to the equation

$$\sigma_{atm}(\lambda, V, h) = \sigma_{atm}(\lambda, V, 0) \exp\left(-\frac{h}{h_v}\right)$$

where V is the sea level visibility and $h_v = 1.2$ km is a visibility scale height. Thus, the one way attenuation from a SLR station at elevation h_g above sea level to a satellite outside the atmosphere is

$$T_{atm}(\lambda, V, h_g) = \exp\left[-\sec\theta_{zen} \int_{h_g}^{\infty} \sigma_{atm}(\lambda, V, h) dh\right]$$

$$= \exp\left[-\sigma_{atm}(\lambda, V, 0) h_v \sec(\theta_{zen}) \exp\left(-\frac{h_g}{h_v}\right)\right]$$

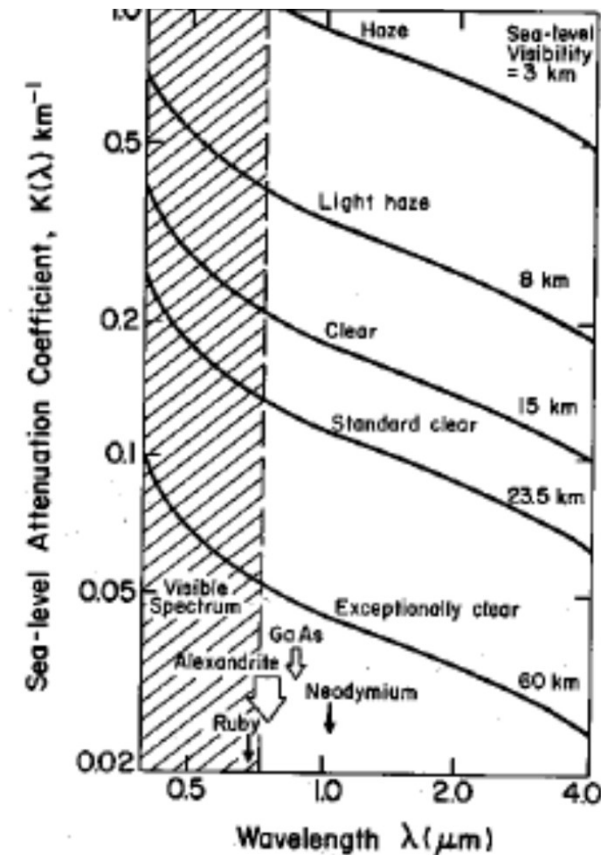

*Graph of Sea level attenuation coefficients obtained from R. J. Pressley, Handbook of Lasers, Chemical Rubber Co., Cleveland (1971).



Atmospheric Turbulence, Scintillation and Speckle



- ◆ In response to a PDR RFA John Degan evaluated the effects of scintillation and speckle. This work was presented in a paper at the ILRS Workshop in Potsdam, German in 2016:

J. Degan “**An Upgraded SGSLR Link Analysis Which Includes the Effects of Atmospheric Scintillation and Target Speckle**”, 20th International Workshop on Laser Ranging, Potsdam, Germany, 2016.

- ◆ The slides that follow (including the link analysis) are from this presentation. The paper is attached to the RFA response.



Combined Effects of Uplink Scintillation and Target Speckle



- ◆ Scintillation and Speckle reduce the return signal strength. Plot at right shows the relative probability of detection (with scintillation and speckle) to what would be calculated by the nominal SLR link equation (Degnan equation shown in earlier slide).
- ◆ The $n_s = 1, 3, 5, 10$ values are the expected return signal strength (in photoelectrons) assuming no losses from scintillation or speckle.
- ◆ The losses are greater at higher zenith angles (lower elevation angles). The losses are also greater for sites that are near sea level (such as GGAO).

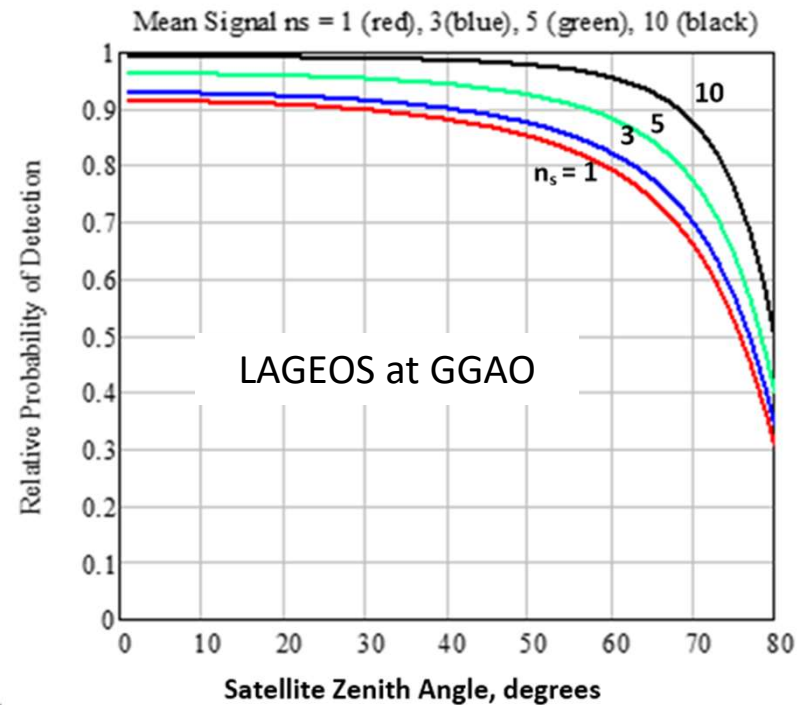

For $n_s = 1$ at a zenith angle of 50° , the actual expected return signal strength will be about 85% of what the link calculation shows without scintillation & speckle.



Effects of Telescope Pointing Bias on Signal Strength



- ◆ Vertical axis of plot is ratio of signal strength with pointing bias to the signal strength with zero bias.
- ◆ Horizontal axis is ratio of pointing bias to half divergence angle
- ◆ For a pointing bias equal to the half divergence angle (ratio of pointing bias to half divergence angle = 1) the return signal strength is only about 15% of what it would be if we were pointing directly at the target.

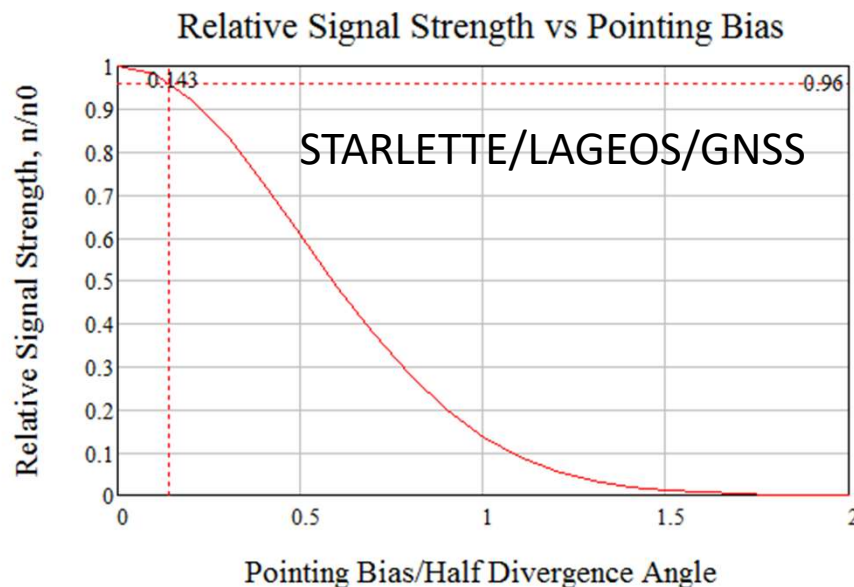

With a 7 arcsec pointing bias and a 28 arcsec full divergence, the ratio of pointing bias to half divergence = 0.5 which implies a return signal strength of about 60% what would be seen with zero pointing bias.



SGSLR Probability of Detection

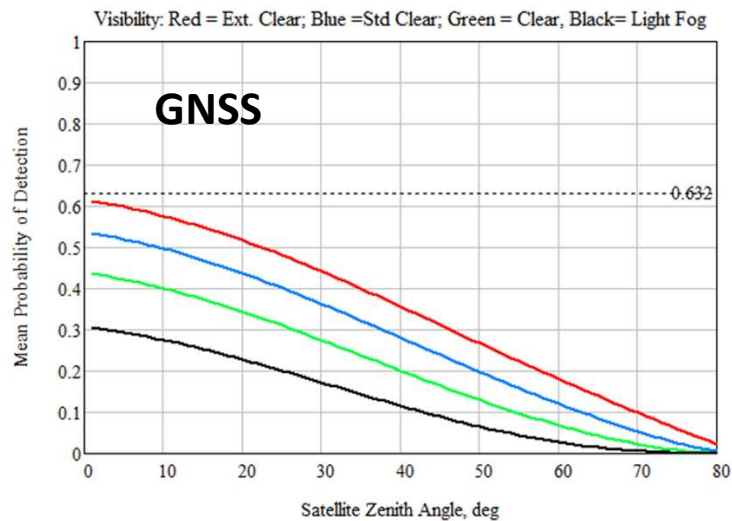
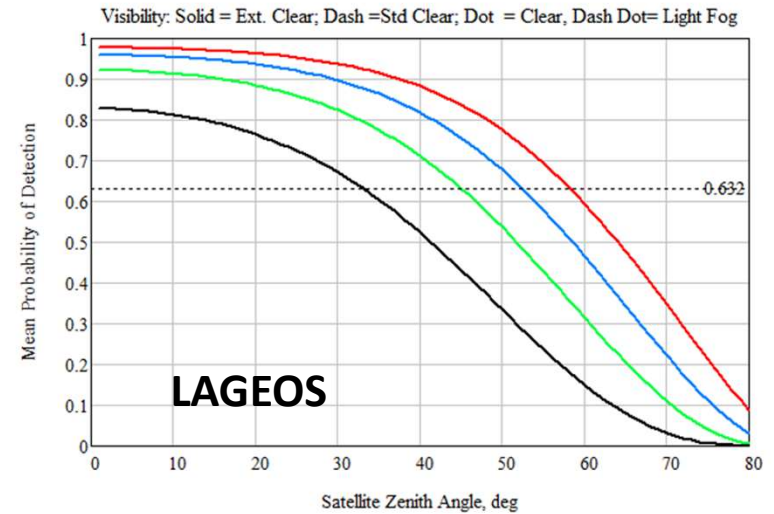
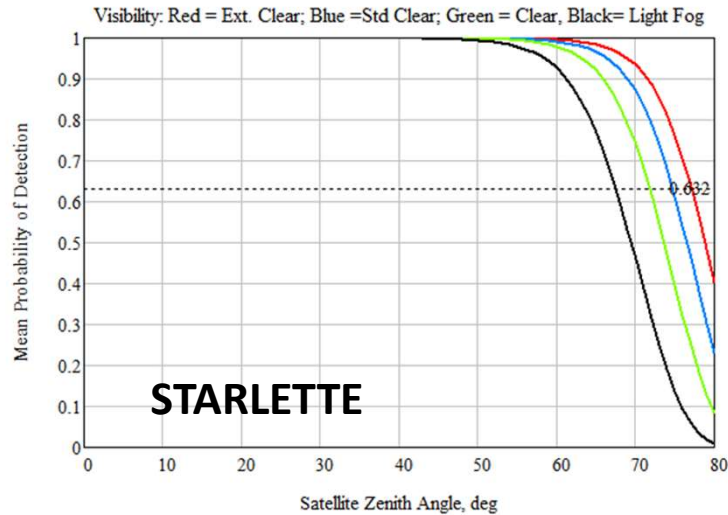

28 arc second full divergence (STARLETTE & LAGEOS)
 14 arc second full divergence (GNSS)
 2 arc second pointing offset
 2 arc second RMS jitter
 Includes effects of scintillation and beam wander
 Sea level (worst case) site

Red = Extremely Clear (V=60 km)
Blue = Standard Clear (V=23.5 km)
Green = Clear (V=15 km)
Black = Light Fog = Light Haze (V=8 km)



System configuration for SGSLR ACQ/TRK



- ◆ Laser divergence and FOV settings for both ACQ/TRK:
 - LEO, LAGEOS: 28 arcsecond full width
 - GNSS: 14 arcsecond full width

- ◆ Acquisition Pointing Bias (from Pointing Error Budget):
 - LEO: 7 arcseconds
 - LAGEOS: 4.1 arcseconds
 - GNSS: 3.7 arcseconds

- ◆ Tracking Pointing Bias (from Pointing Error Budget):
 - 3.5 arcseconds

- ◆ All calculations assume 2 arcsecond GTA jitter



Link calculations for SGSLR configuration



- ◆ Using previous link calculation plots and scaling for the configuration given on previous slide:
 - LEO (STARLETTE):
 - Clear (ACQ at 10° EL has 0.06 pes; TRK at 10° EL has 0.09 pes)
 - Light Haze (ACQ at 15° EL has 0.06 pes; TRK at 15° EL has 0.09 pes)
 - LAGEOS:
 - Clear (ACQ at 15° EL has 0.04 pes; TRK at 15° EL has 0.05 pes)
 - Light Haze (ACQ at 20° EL has 0.03 pes; TRK at 20° EL has 0.03 pes)
 - GNSS:
 - Clear (ACQ at 25° EL has 0.03 pes; TRK at 25° EL has 0.04 pes)
 - Light Haze (ACQ at 35° EL has 0.04 pes; TRK at 35° EL has 0.04 pes)
 - GEO:
 - 0.001 pes at or above 20°

So even in light haze:

- **LEO has expected > 0.06 pes at 15°**
- **LAGEOS has expected > 0.03 pes at 20°**
- **GNSS has expected > 0.04 pes at 35°**

Note: pes = expected photoelectrons/fire



Performance Analysis: Acq/Trk Capability



SGSLR Background Noise



- ◆ The worst case solar noise for SGSLR occurs at low elevation angles.
- ◆ Dark count rate for an MCP/PMT is nominally 50 kHz.
- ◆ For a 14 arcsec full-width FOV solar background = ~ 8 MHz
 - For 45 pixel array with 14 arcsec FOV the combined worst case solar noise and dark counts ~ 180 kHz / pixel.
 - For a 500 ns range window width this implies about 0.11 noise counts per pixel per range window (adding in dark count rate)
- ◆ For a 28 arcsec full-width FOV solar background = ~ 32 MHz
 - For 45 pixel array with 28 arcsec FOV the combined worst solar noise and dark counts ~ 720 kHz / pixel
 - For a 500 ns range window width this implies about 0.44 noise counts per range window
- ◆ At night, the noise is 0.0006 pes/pixel/fire, which greatly reduces the required signal detection time



Signal Detection (14" FOV & Divergence)



Signal Detection using the Spatial Histogram from the Pixelated Array

Want: $\mu'_S + \mu'_N > \mu'_N + 3 \cdot \sigma'_N$

where the means and std are over a number of fires N

$$\mu'_S = N \cdot \mu_S \quad \mu'_N = N \cdot \mu_N \quad \sigma'_N = \sqrt{N \cdot \mu_N}$$

Solving for N, want $N > 9 \cdot \mu_N / \mu_S^2$

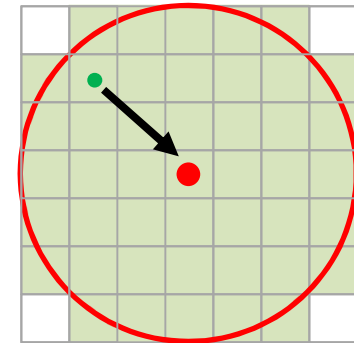

Using the **expected background rate of 0.11 pes/pixel/fire** from the previous slides, and assuming that all of the satellite returns fall into a single pixel:

Signal return rate	Number of fires	Seconds to find signal
0.005 pes/fire	39600	19.8 seconds
0.010 pes/fire	9900	5.0 seconds
0.020 pes/fire	2475	1.2 seconds
0.030 pes/fire	1100	< 1 second
0.050 pes/fire	396	< 1 second

Even in light haze all have expected > 0.03 pes which requires < 1 sec to detect signal (goal < 20 sec).



Signal Detection (14" FOV & Divergence cont)



All of the satellite returns may not fall into a single pixel.

Assuming 4 pixels needed to cover the satellite returns, then the max daylight **background rate** per 2x2 pixel subset will be = 4 x 0.11 pes/fire = **0.44 pes/fire**.

Signal return rate	Number of fires	Seconds to find signal
0.005 pes/fire	158400	> 60 seconds
0.010 pes/fire	39600	19.8 seconds
0.020 pes/fire	9900	5.0 seconds
0.030 pes/fire	4400	2.2 seconds
0.050 pes/fire	1584	< 1 second

Too long

Even in light haze all have expected > 0.03 pes which requires < 3 sec to detect signal (goal < 20 sec).



Signal Detection (28" FOV & Divergence)



In this FOV each pixel represents 4 arcseconds. If all signal falls within a single pixel, this case is the same as signal detection in 2x2 pixels with FOV = 14".

If the satellite returns fall in 4 pixels then the max daylight **background rate** per 2x2 pixel subset will be = **1.76 pes/fire**.

Signal return rate	Number of fires	Seconds to find signal
0.005 pes/fire	Too many	Too long
0.010 pes/fire	158400	> 60 seconds
0.020 pes/fire	39600	19.8 seconds
0.030 pes/fire	17600	8.8 seconds
0.050 pes/fire	6336	3.2 seconds

Too long

Too long

Even in light haze all have expected > 0.03 pes which requires < 9 sec to detect signal (goal < 20 sec).



System ACQ/TRK capabilities



- ◆ **Previous slides have shown that, even with angular biases from the pointing error budget allocations, and with max daylight background:**
 - For light haze, LEOs can be acquired and tracked in daylight down to 15° (20° for LAGEOS, 35° for GNSS). Lower at night.
 - The signal detection time is < 10 seconds for all conditions shown.
- ◆ **These are conservative estimates:**
 - Background noise
 - Pointing errors
 - Number of pixels signal is spread over
- ◆ **This means we expect to be able to acquire and track with lower expected return pes/fire, so lower elevations and/or worse atmospheric conditions**



False Alarms



- ◆ With a 3*sigma threshold level, the probability of false alarm (when there is little or no signal) is about 0.3%.
- ◆ With 45 independent pixels, this means that for any given signal calculation the probability of a false alarm is 13.5%. While this is not an issue when signal is strong, it could drive the telescope off the target for periods of weak or no signal.
- ◆ False Alarms can be greatly reduced with either requiring multiple spatial histograms to pick the same pixel, or potentially better, to perform both spatial and time histograms on the data.
- ◆ Analysis and simulation show spatial and time histogramming reduces probability of False Alarm to < 1%.



Acquisition & Tracking Conclusions



- ◆ Expected returns for LEO to GNSS during full daylight have been shown to be robust, quickly acquired, and easily tracked
- ◆ Angular information from the receiver will ensure that the target remains within an optimal offset of the receiver field of view
- ◆ Night time acquisition and tracking will be robust for all satellites up to and including GEO



Performance Analysis: Data Volume



Calculating the Data Volume (1 of 2)



- ◆ For GGAO our Data Volume calculations used:
 - 50% weather outage & 16% other outage (maintenance, etc.) = 66% of time with no tracking
 - 40% data collection rate from all of the other times (=> 60% data loss when tracking or attempting to track)
 - No real-time interleaving of GNSS or LAGEOS passes
- ◆ Average time of pass segments: ~5 minutes
- ◆ Giving acquisition 20% of the data loss when attempting tracking => acquisition time must be < 60 seconds



Calculating the Data Volume (2 of 2)



- ◆ Based on link calculations, for light haze or clearer, above 15 degrees, LEO acq < 60 seconds
- ◆ Based on link calculations, for light haze or clearer, above 20 degrees, LAGEOS acq < 60 seconds
- ◆ Based on link calculations, for light haze or clearer, above 35 degrees elevation, GNSS acquisition < 60 seconds
- ◆ To minimize search time, we will limit attempts at acquisition for LAGEOS > 15 deg elevation, and for GNSS > 30 deg elevation.
- ◆ Weather conditions that are worse than light haze will be rejected by the use of the all sky camera.
- ◆ **With mount pointing accuracy < 3 arcsec RMS, the system will satisfy the inputs to the data volume simulation on the next slide, which shows SGSLR successfully meeting the data volume, precision and stability requirements even under worst case daylight conditions.**



Expected Performance against Global Station Performance



Data volume from ILRS Global Report Card: April 2013 thru March 2014

Site ID	Station Number	LEO NP Totals	LAGEOS NP Totals	High NP Totals	LAGEOS Average Precision (mm)	JCET Long Term Stability (mm)
YARL ¹	7090	176,683	20,634	21,986	1.9	2.5
GODL ²	7105	76,554	7,666	3,052	2.0	3.5
CHAL	7237	69,438	7,235	14,735	0.8	4.1
STL3	7825	78,089	7,218	3,984	1.9	1.5
GRZL	7839	75,714	5,468	18,016	0.2	1.8
HERL	7840	38,592	7,018	6,069	1.9	1.2
WETL	8834	46,509	5,053	12,683	1.6	3.0
SGSLR(20°)	@7105	53,400	7,400	12,200	<1.5	<1.8
SGSLR(10°)	@7090	200,000	18,500	26,400	<1.5	<1.8
Requirement		45,000	7,000	10,000	<1.5	<2.0

Projected SGSLR annual NP data volume³:

(20°) 50% weather outage, 16% other outage, 40% data collection when active, min 20° elevation

(10°) 14% weather outage, 16% other, 40% data collection when active, min 10° elevation

¹YARL has 14% weather outage and tracks to 14° elevation

²GODL has 50% weather outage and tracks down to 10° elevation

³Precision and stability numbers for SGSLR are based upon SGSLR analysis and NGSLR performance



Data Volume Conclusions



- ◆ Simulations show SGSLR meeting the data volume requirement even with 50% weather outages
- ◆ SGSLR performs as well as most of the best ILRS stations when allowed to track down to 10 degrees and with weather outages that are minimal (as at Yarragadee)
- ◆ Real-time interleaving was not simulated – this will greatly increase the number of LAGEOS and GNSS Normal Points

All inputs to this calculation are very conservative and actual data volumes numbers are expected to be higher



SGSLR System Design



Internal Interface Overview

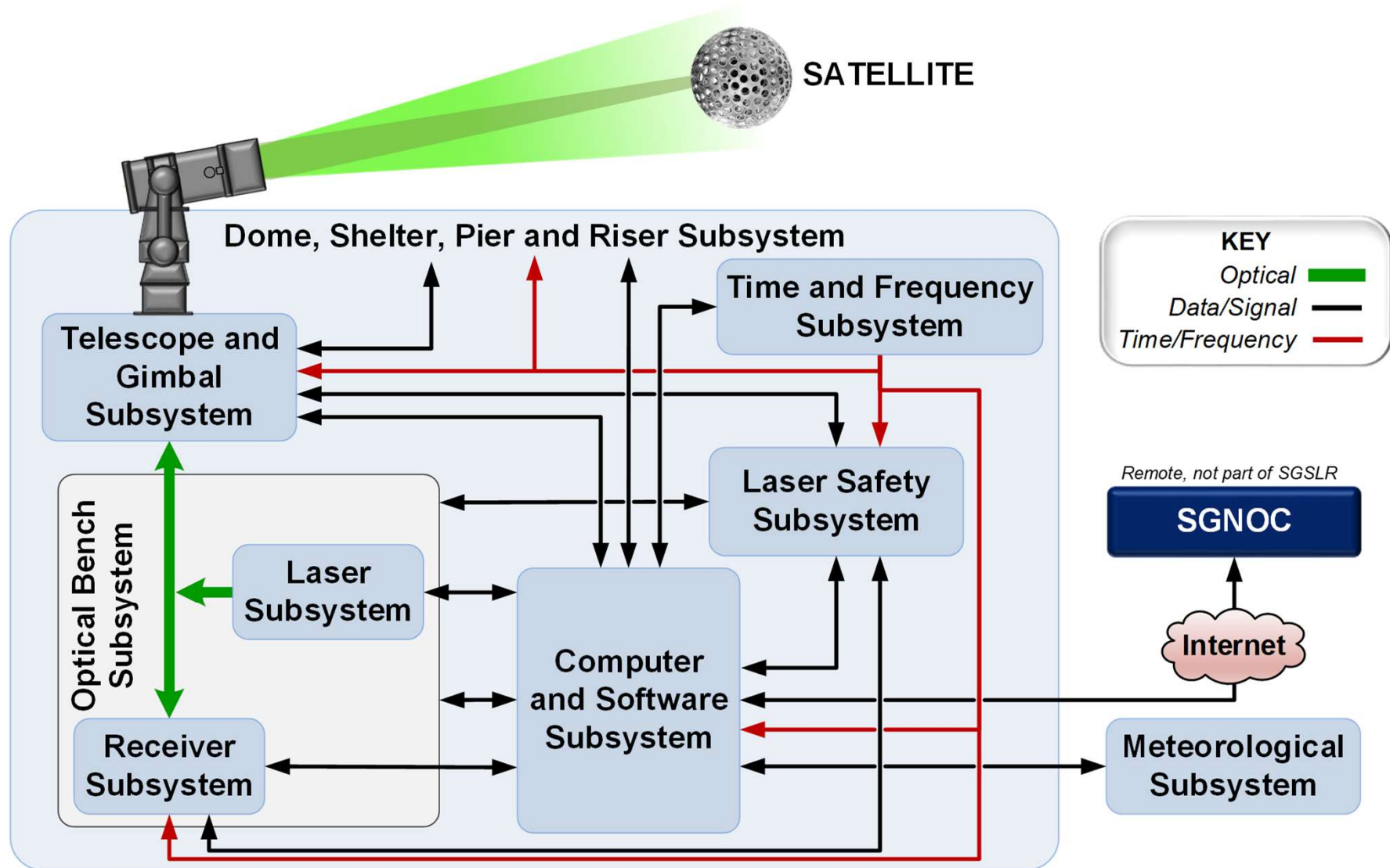

Drawing D-011a



SYSTEM OPTICAL DESIGN

Design Lead: Joe Marzouk



Simplified Optical System Layout

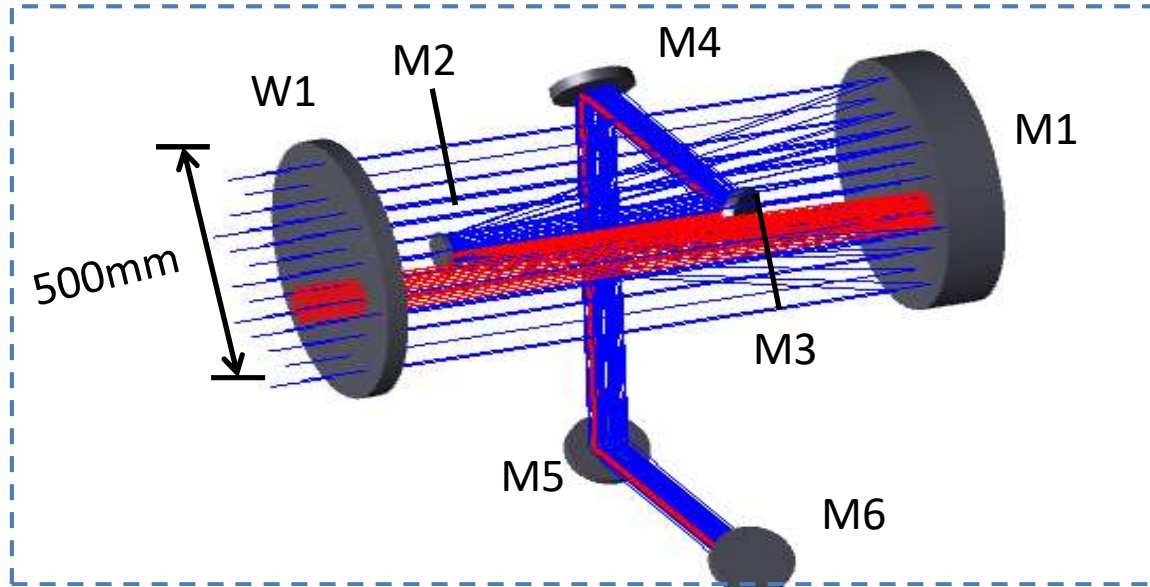

Telescope Assembly
Beam Compression
ratio: 6.944:1

System uses a classic coudé feed; The optical and mechanical axes are co-aligned. Transmit and receive path are coupled using an insertion fold mirror.

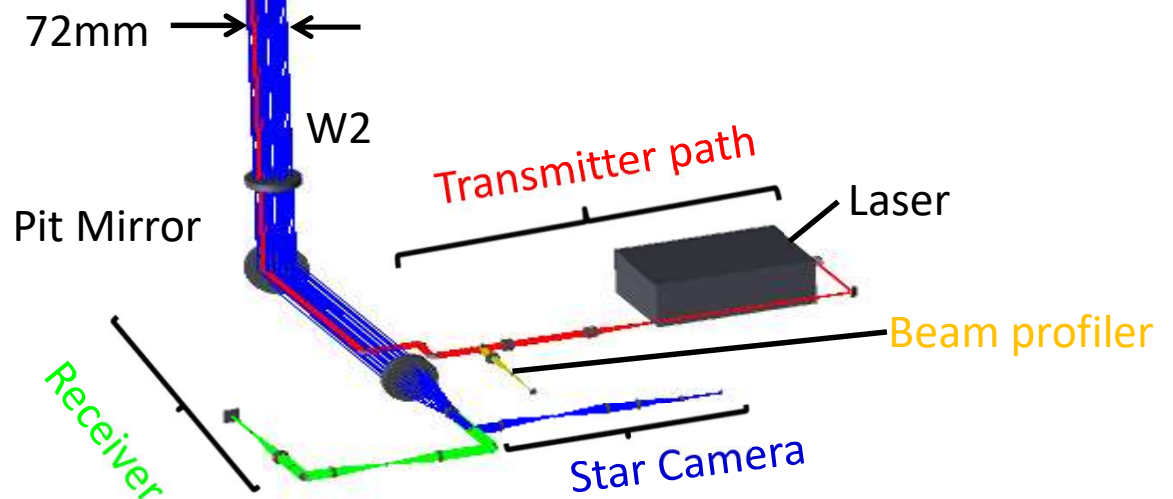



Optical Paths on the Optical Bench

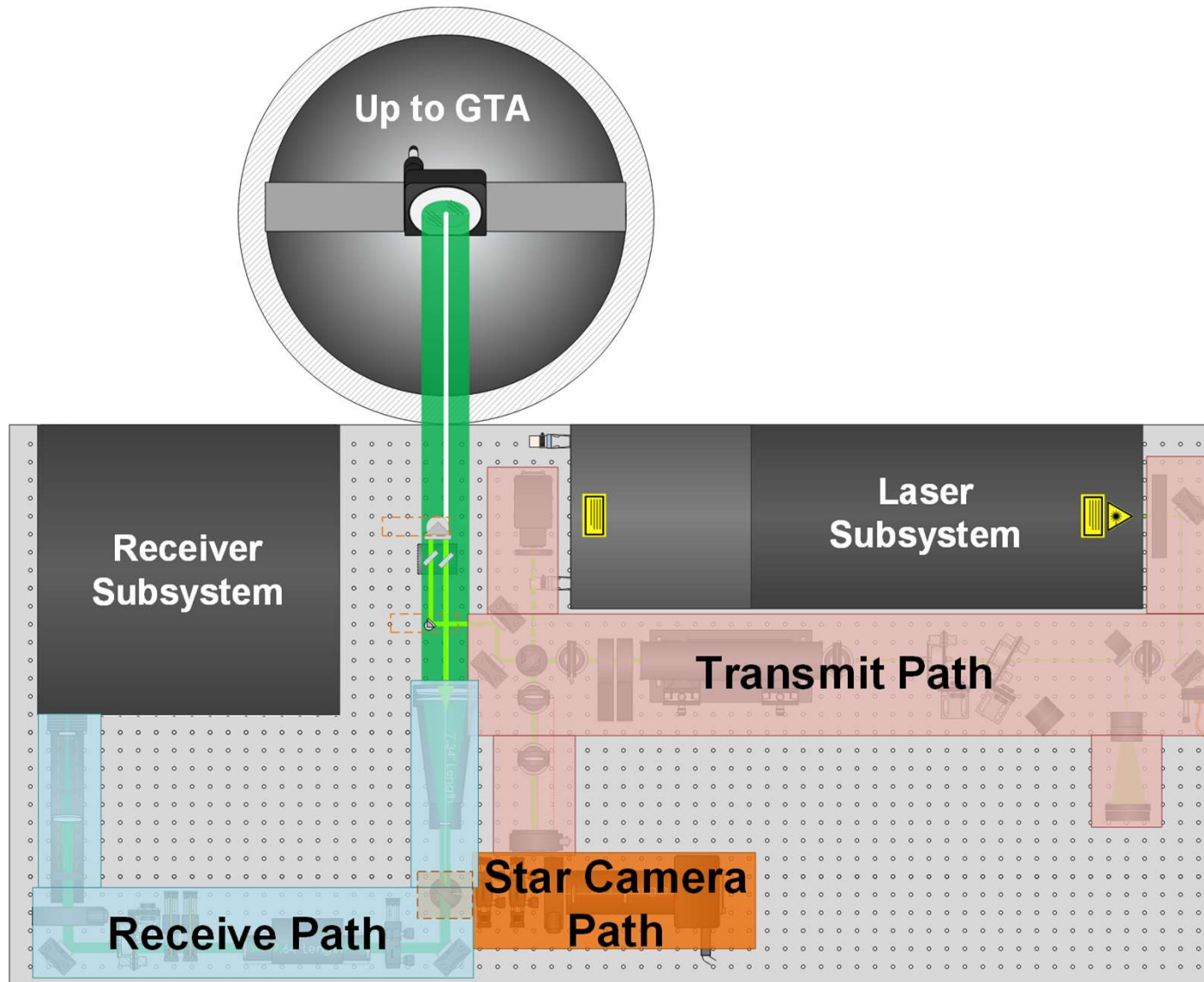



Transmit Leg

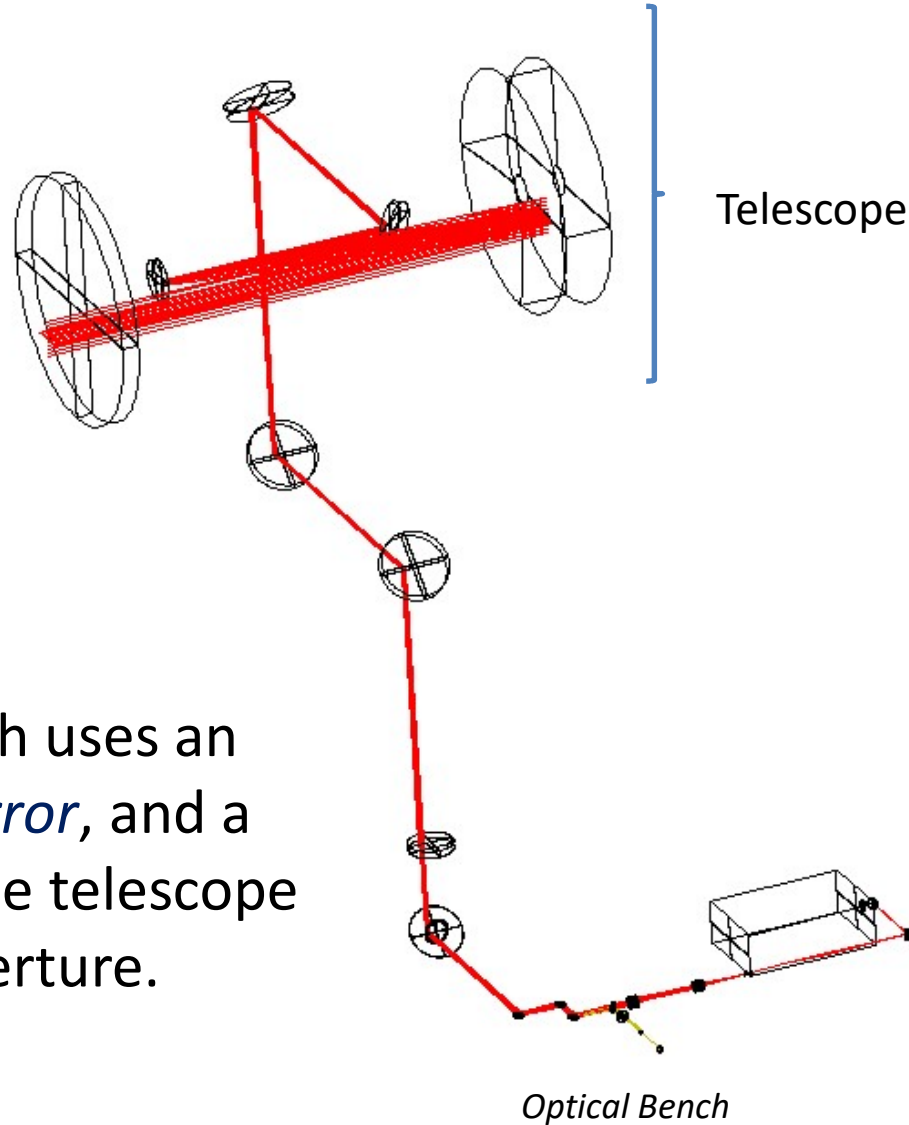

Transmit path uses an *insertion mirror*, and a portion of the telescope outgoing aperture.



Transmit Optics Layout

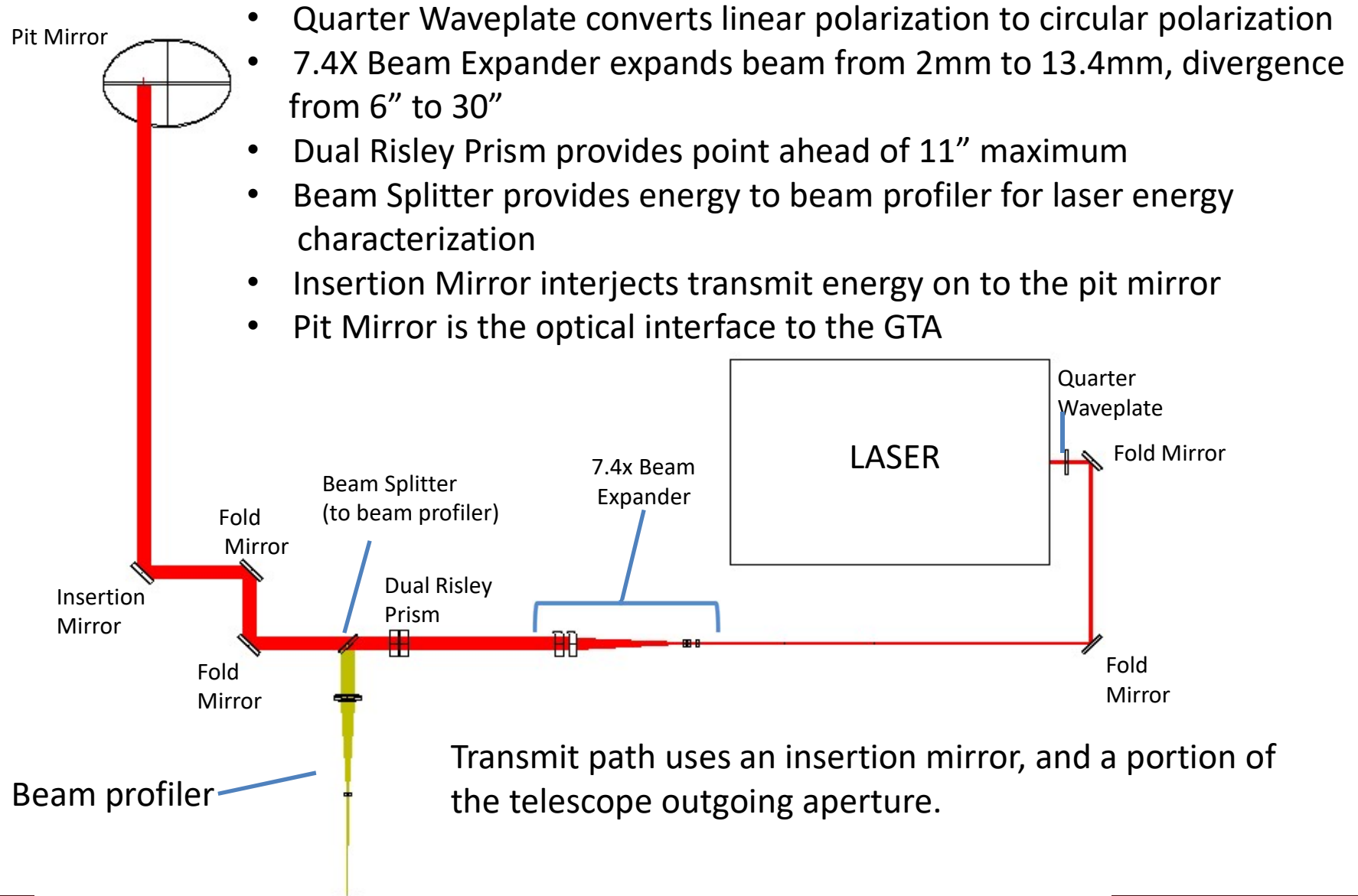



Receive Path

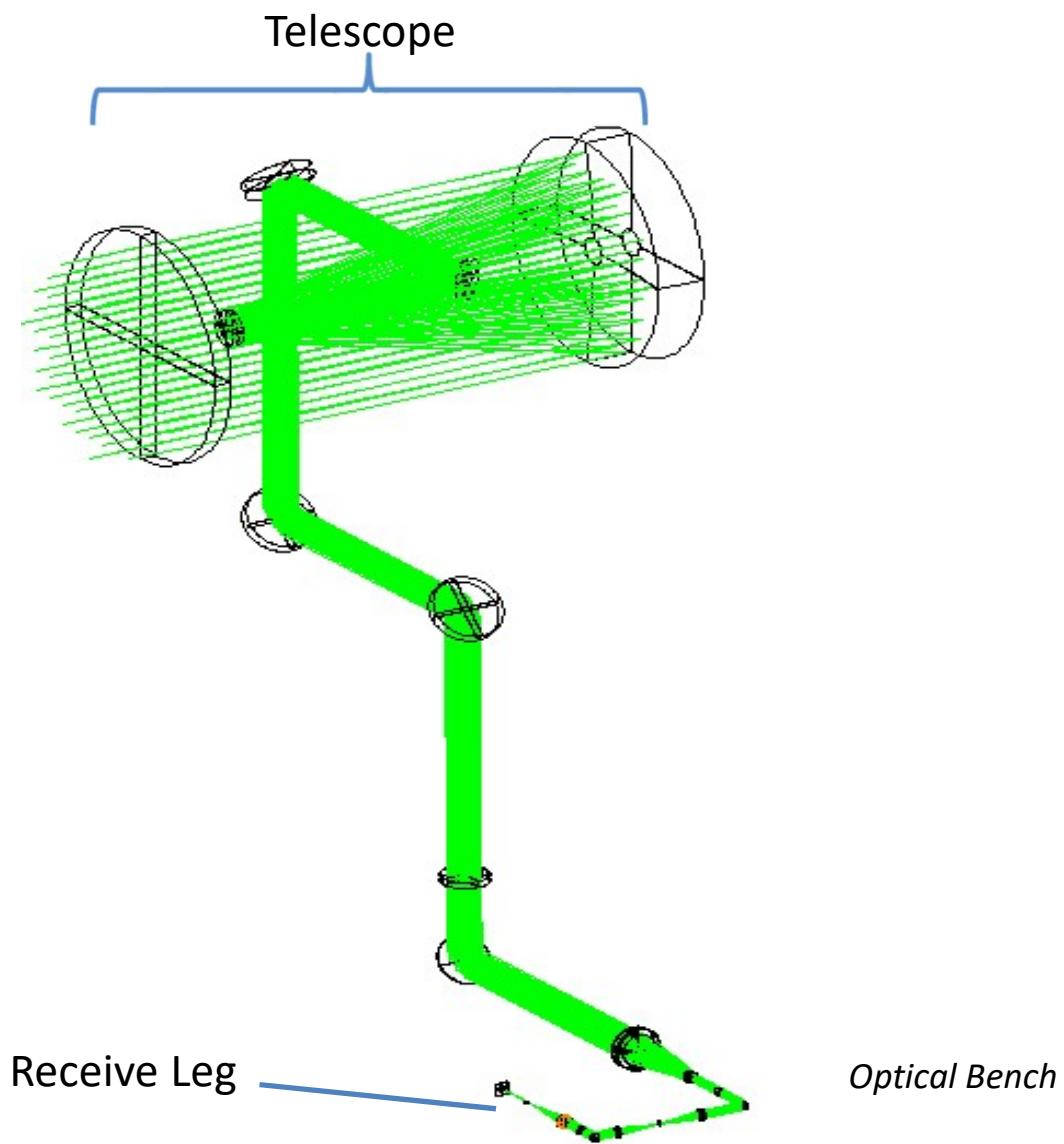



Receive Optics Layout

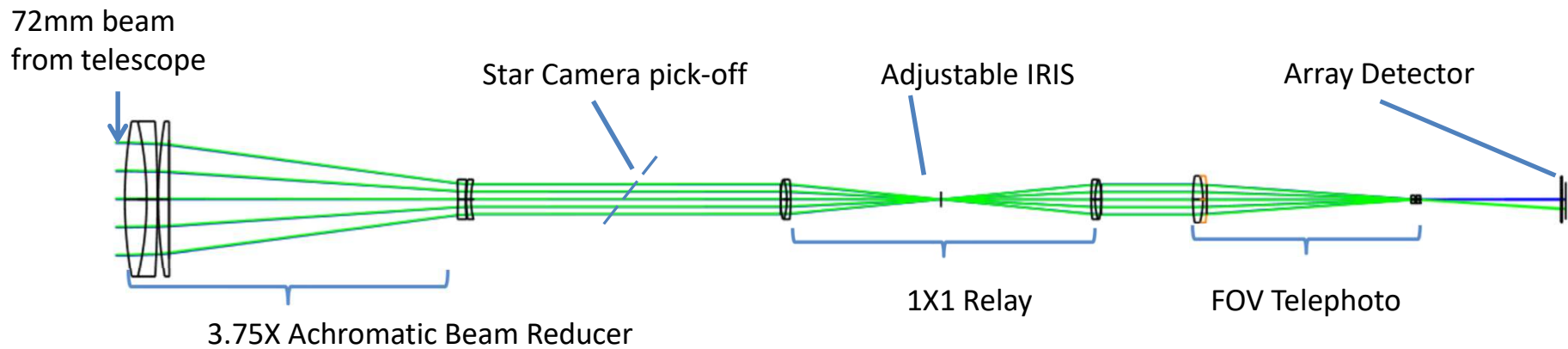

- 3.75X Beam Reducer reduces beam diameter from 72 mm to 19.2 mm
- Star camera pick-off (beam splitter) directs broadband light to star camera
- 1X1 Relay limits FOV (stray light) from 14" to 60"
- FOV Telephoto provides adjustable FOV from 14" to 60" into detector



Star Camera Path

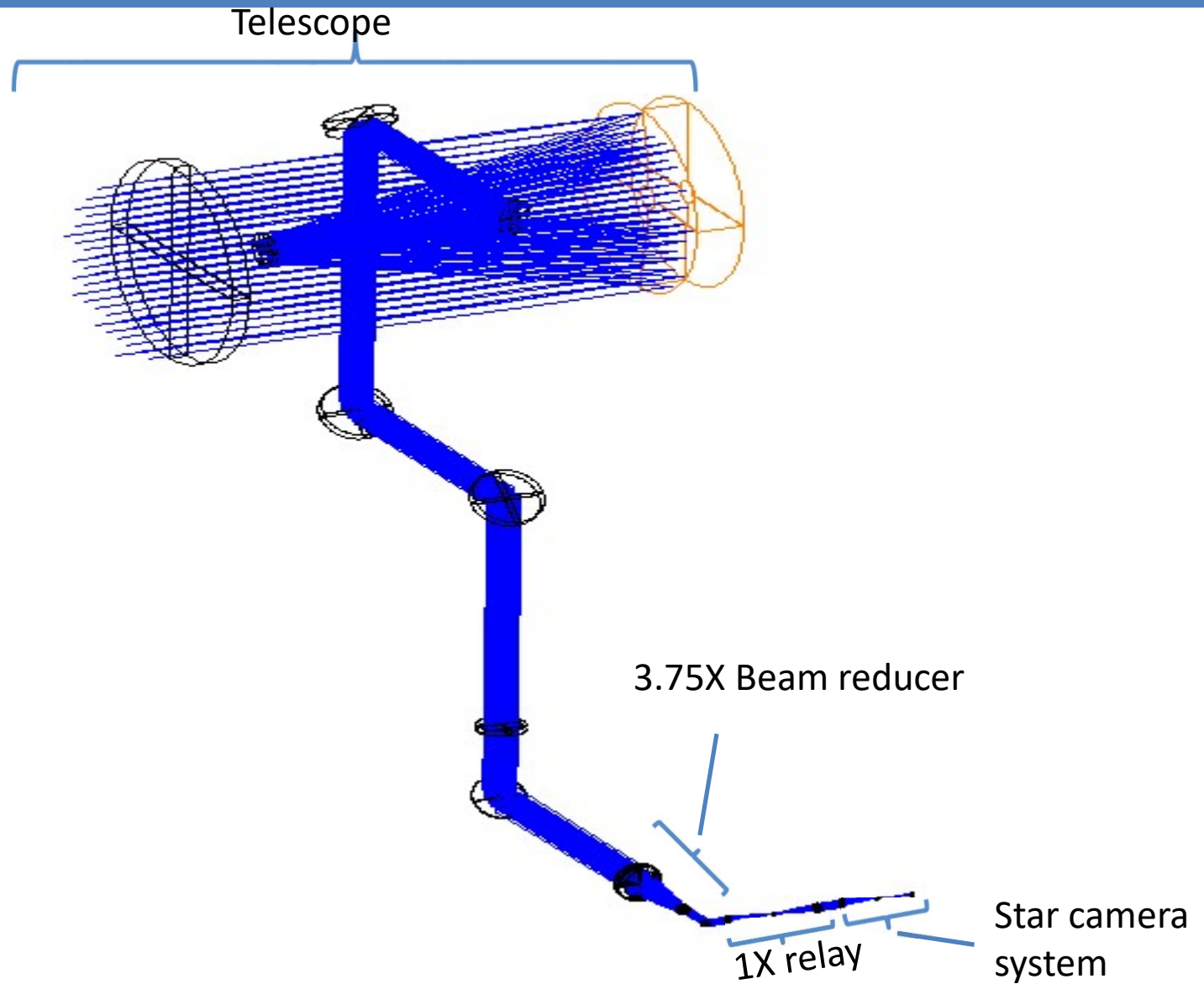



Star Camera Path

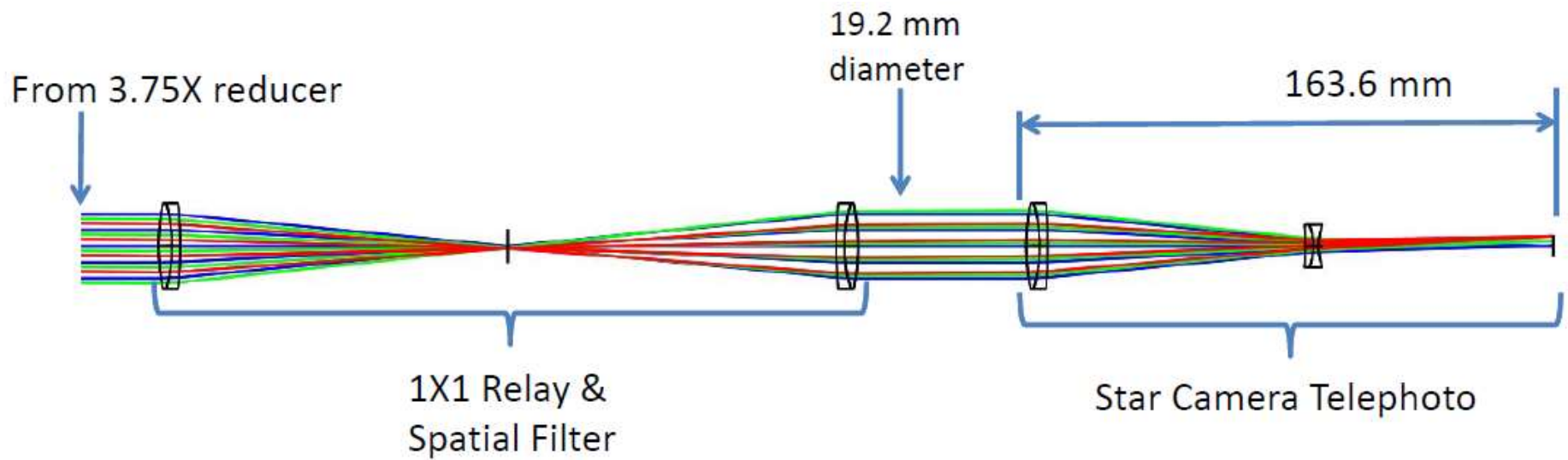

- 1X1 Relay and Spatial Filter for background reduction
- Star Camera Telephoto provides star image on camera in 2 arc minute object space



SYSTEM MECHANICAL DESIGN

Design Lead: Howard Donovan



3D View of Shelter Exterior

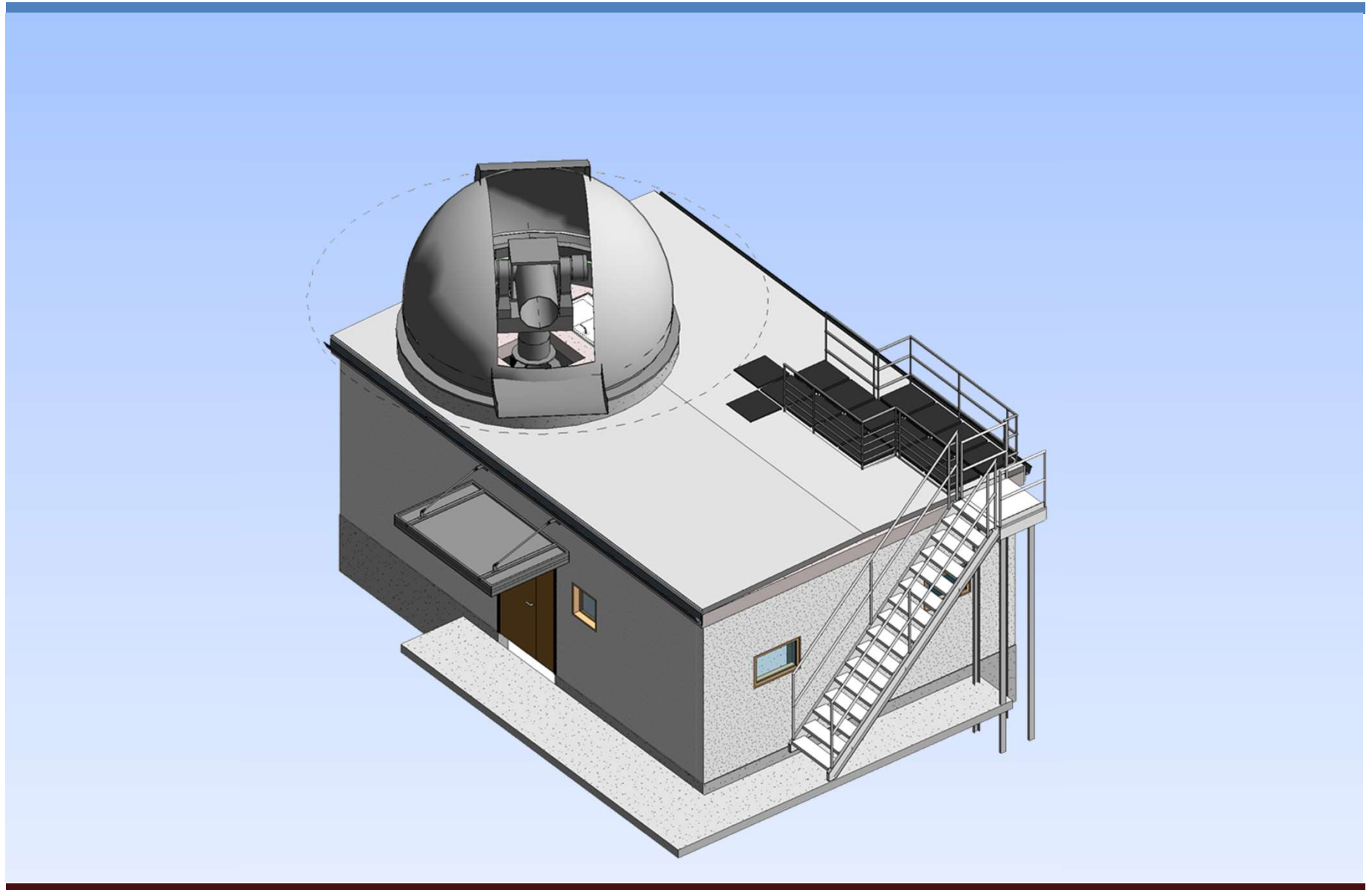



Section of Shelter

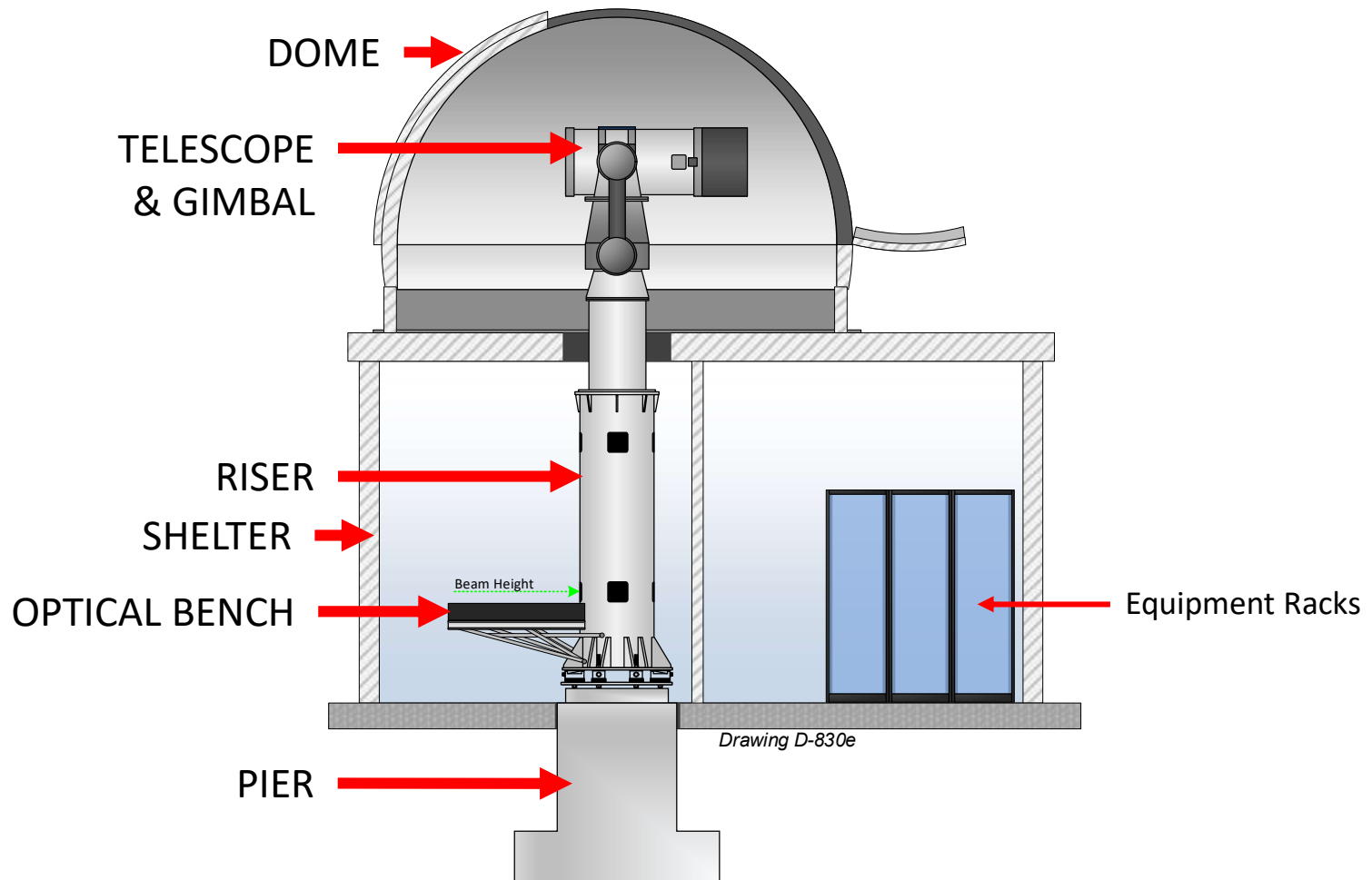



Riser and the Optical Bench

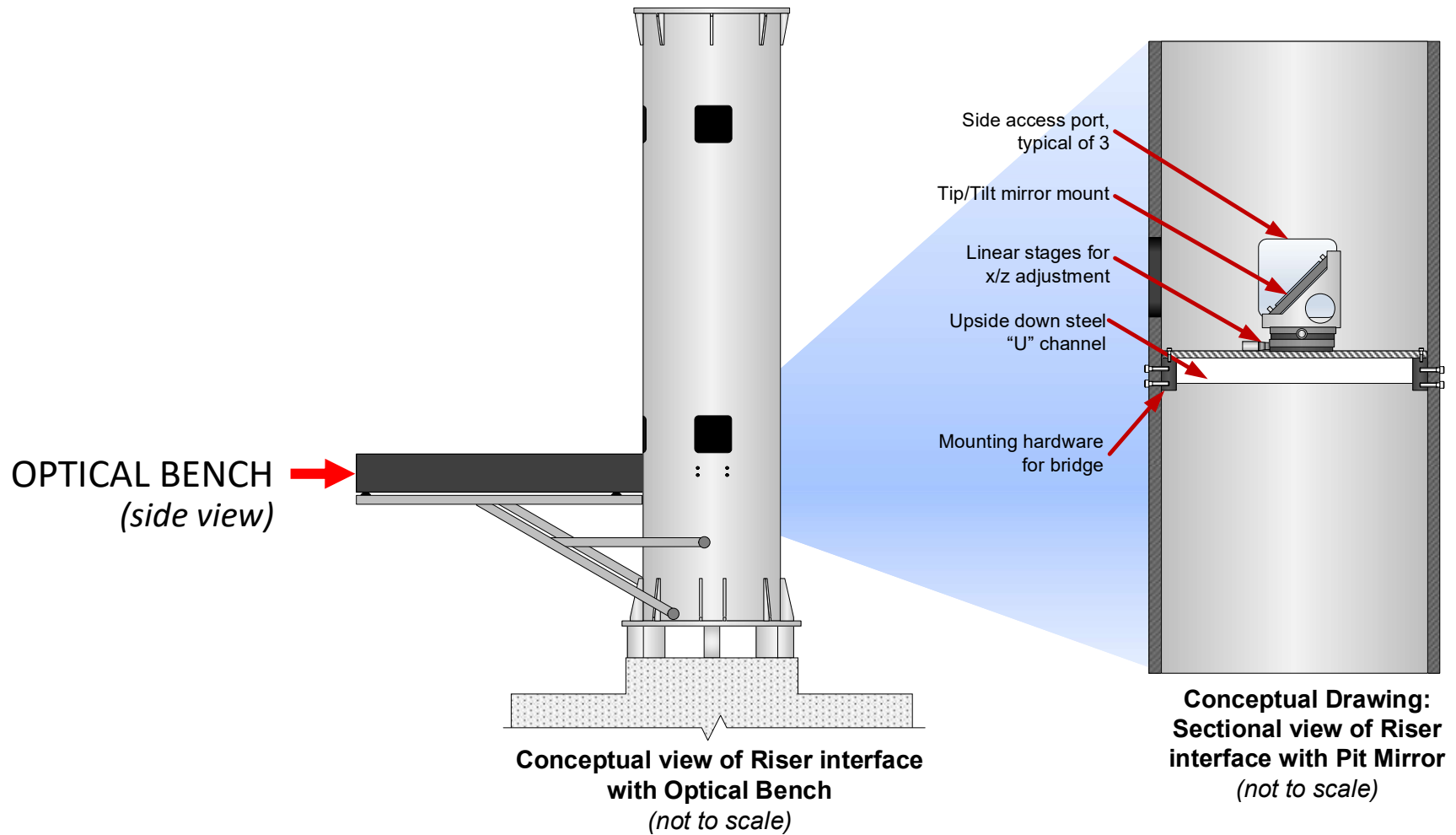



Shelter – Plan View

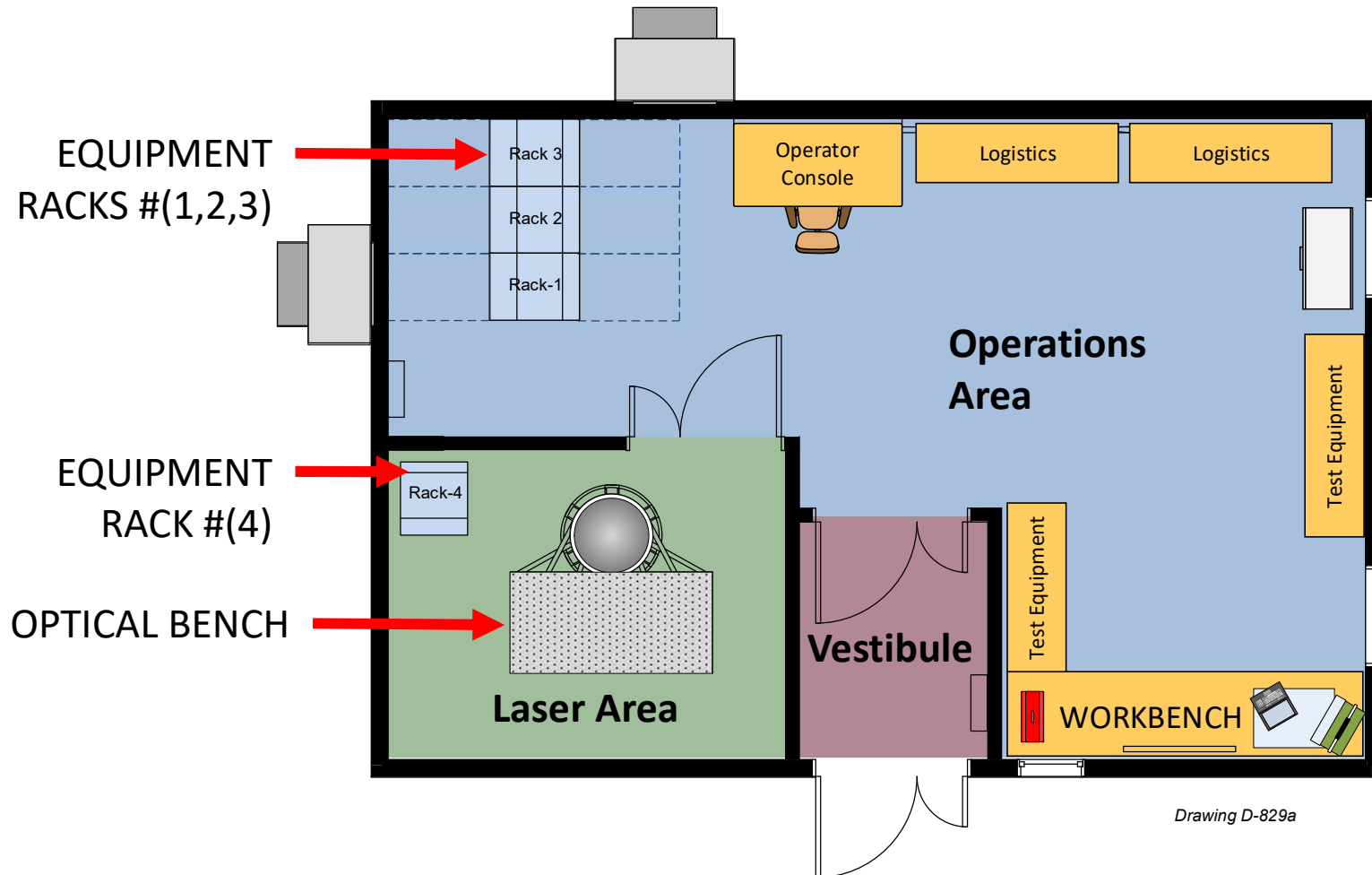

Drawing D-829a



SYSTEM ELECTRICAL POWER DESIGN

Design Lead: Howard Donovan



Simplified Power Distribution Diagram

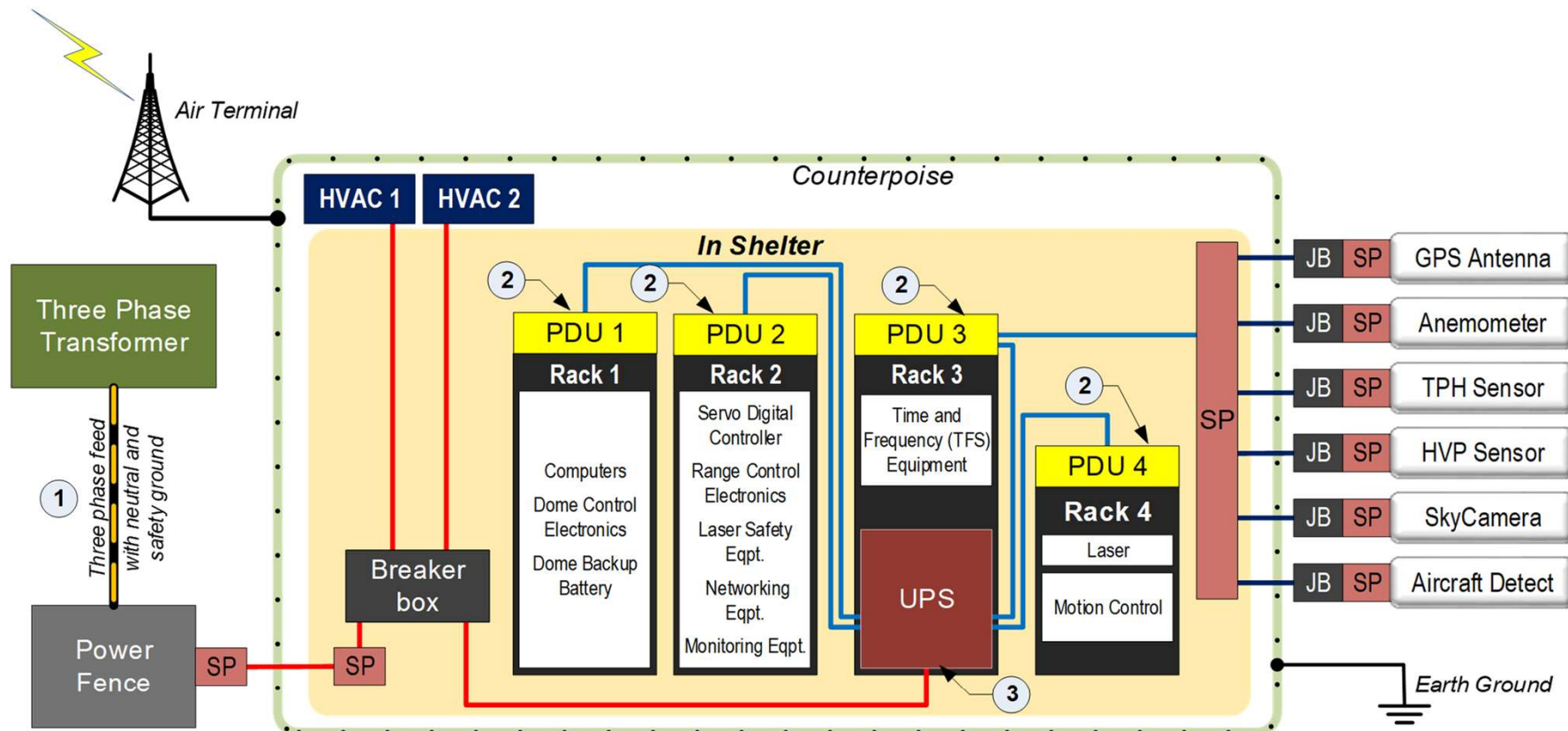

DRAWING NOTES

- 1 Five wire, three phase feed (A, B, C) system with neutral and ground isolated back to the transformer.
- 2 PDU units are used to provide, monitor and control (ON/OFF) power.
- 3 UPS unit is used to provide, monitor and control (ON/OFF) conditioned power.

KEY

	Counterpoise (leads to ground field)		Electrical Junction Box
	Three phase feed (5 wire)		Surge Protection
	Three phase (5 wire)		Uninterruptable Power Supply
	Single phase		Power Distribution Unit
	Conditioned single phase		

Drawing D-828a



SYSTEM DATA & SIGNAL DESIGN

Design Lead: Howard Donovan



Inter-subsystem Interfaces

Data & Signal



- ◆ Slide removed due to export control regulations



SYSTEM INTERFACE OVERVIEW

Design Lead: Howard Donovan



Critical Mechanical Interfaces



- ◆ Mechanical interfaces between subsystems have been identified and defined
- ◆ These include:
 - Telescope and Gimbal to Riser
 - Riser to Pier
 - Riser to Optical Bench



Critical Mechanical Interfaces



 Line of demarcation between critical mechanical interfaces

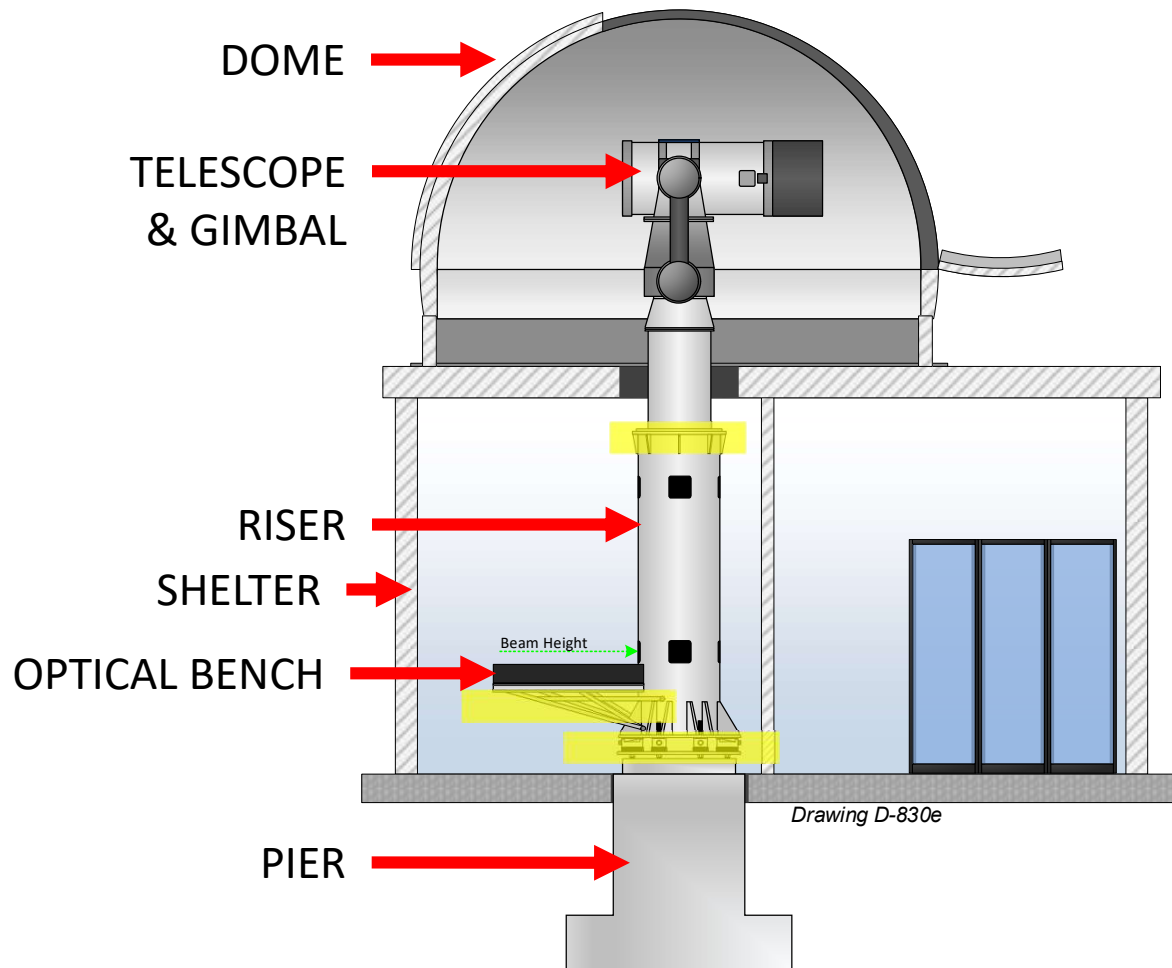



LUNCH

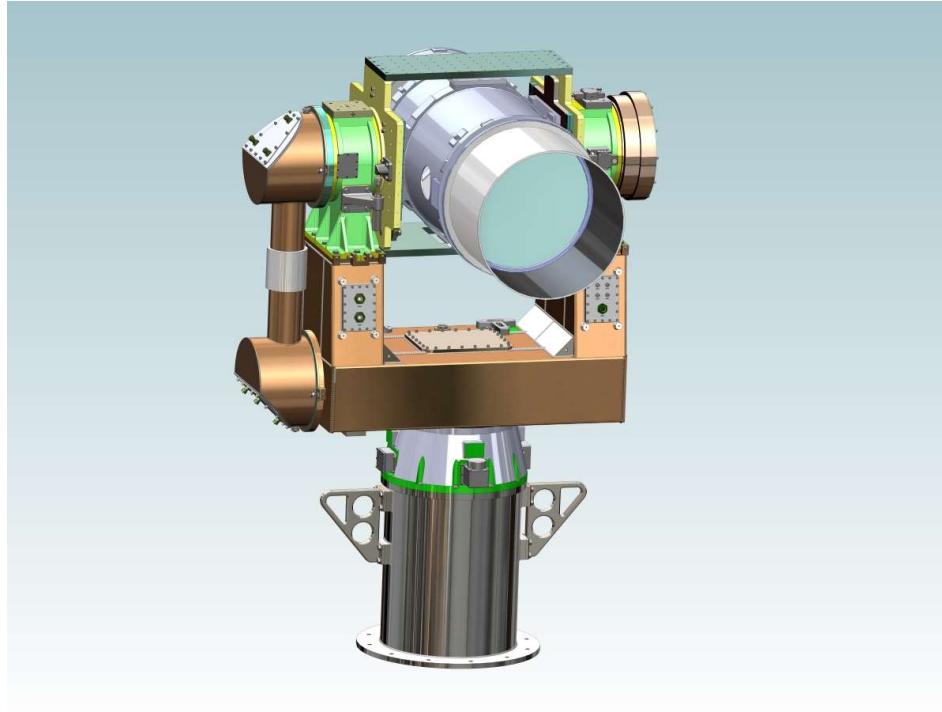

TELESCOPE AND GIMBAL SUBSYSTEM

Design Lead: Scott Wetzel

Additional details can
be found in EPR slides
and ICD document



Telescope and Gimbal Subsystem



◆ Purpose of subsystem

- To accurately and reliably point the telescope at the satellite, transmit the laser, and receive the ranging signal
- To feed the Optical Bench (and Receiver) with the ranging signal from the satellite



Telescope and Gimbal Subsystem



◆ Key Specifications

- Azimuth 0° to 360° (continuous)
- Elevation 7° to 90° (tracking)
- Absolute Pointing ≤ 3 arcsec RMS*
- Jitter ≤ 1 arcsec
- Azimuth \ Elevation Velocity 0 to $5^{\circ}/\text{sec}$
- Azimuth \ Elevation Acceleration 0 to $5^{\circ}/\text{sec}^2$
- Invariant Point Knowledge ≤ 1 mm in 3D space
- Slew Rate $20^{\circ}/\text{sec}$
- Operational Range -40°C to $+50^{\circ}\text{C}$
- Operational wind velocity ≤ 40 mph**

*after modeling from star calibration

** with dome protection



Telescope and Gimbal Subsystem Inter-Subsystem ICD



- ◆ Slide removed due to export control regulations



Telescope and Gimbal Subsystem Design Diagram



- ◆ Slide removed due to export control regulations



Telescope and Gimbal Subsystem



◆ Status of build

- Telescopes being fabricated
- Gimbal unit 1 and controller are undergoing testing at the manufacturer
- Gimbal unit 2 is under integration
- SGSLR team initiated testing at the vendor facility
 - Software ready for testing
 - Test plan written
 - Test hardware being procured



◆ Location of activity

- Cobham - Lansdale, PA
- GSFC / GGAO
- MGO



Telescope and Gimbal Subsystem



- ◆ Path forward/work left to be done
 - Vendor to complete Telescope and Gimbal assembly for each site
 - Conduct Factory Acceptance Tests (FAT)
 - Install GTA 1 at GSFC / GGAO site and perform Site Acceptance Tests (SAT)
 - Deploy GTA #1 to Ny-Ålesund after SAT
 - Install GTA 2 at GSFC / GGAO site and perform Site Acceptance Tests (SAT)
 - Install GTA 3 at MGO site and perform Site Acceptance Tests (SAT)

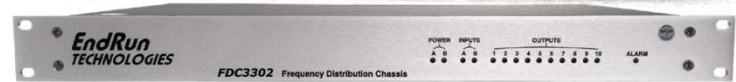
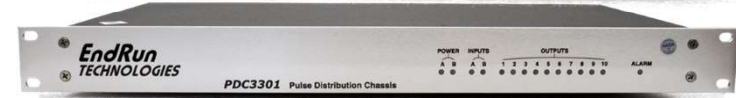

TIME AND FREQUENCY SUBSYSTEM

Design Lead: Irv Diegel

Additional details can be found in EPR slides and ICD document



Time and Frequency Subsystem



◆ Purpose of subsystem

— Time and Frequency Source

- Provides stable and accurate time & frequency signals to SGSLR subsystems
- GPS steering provides the tie to USNO for critical system events

— Signal Distribution

- Distributes signals provided by the T&F source to the various SGSLR subsystems

— Internal Monitoring

- Measures the relationship between station time and USNO as well as the relative stability of the distributed timing signals



Time and Frequency Subsystem



◆ Key Specifications

- 10 MHz Frequency Reference Stability
 - @ 1 Second $\leq 7 \times 10^{-11}$
 - @ 1 Day $\leq 2 \times 10^{-12}$
- IRIG-B Accuracy
 - DCLS 200 ns of UTC
 - AM 10 μ S of UTC
- 1 PPS Accuracy 15 ns to UTC
- Monitoring Accuracy
 - Time Resolution: 12.2 ps LSB, 48 bit range
 - Jitter: < 10 ns/second



Time and Frequency Subsystem Inter-Subsystem ICD



- ◆ Slide removed due to export control regulations



Time and Frequency Subsystem Design Diagram



- ◆ Slide removed due to export control regulations



Time and Frequency Subsystem



- ◆ Status of build
 - Major components have been procured for SW Laboratory
 - Component acceptance test plan and procedures written
 - Component testing in progress with many complete
 - Custom chassis have been assembled and are undergoing characterization and testing
- ◆ Location of activity
 - KBRwyle
 - GSFC / GGAO

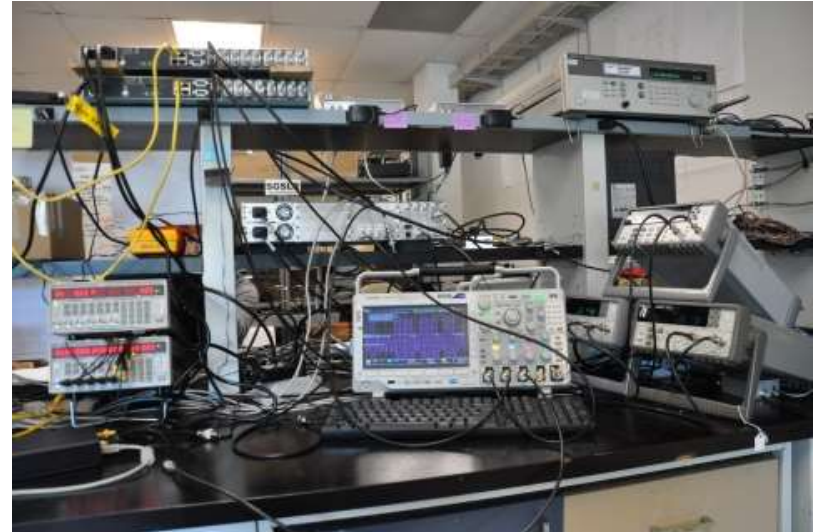



Time and Frequency Subsystem



- ◆ Path forward/work left to be done
 - Write subsystem acceptance test plan and procedures
 - Procure components for SGSLR facility
 - Complete the characterization and testing of each component
 - Assemble components into the T&F subsystem
 - Test and characterize as a subsystem
 - Deliver Time and Frequency Subsystem to SGSLR facility



OPTICAL BENCH SUBSYSTEM

Design Lead: Howard Donovan

Additional details can be found in EPR slides and ICD document





Optical Bench Subsystem



◆ Purpose of subsystem

- Serve as the optical interface between the Telescope and Gimbal, Laser, and Receiver Subsystems

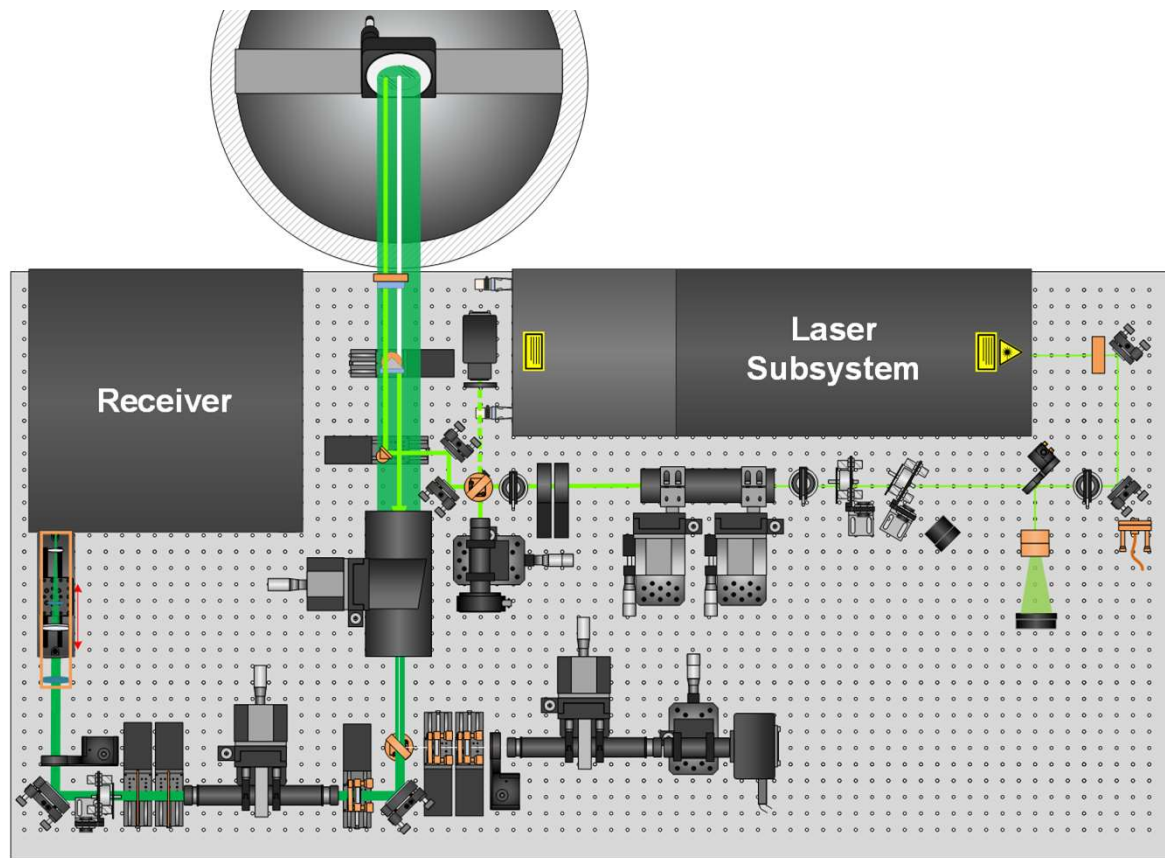



Optical Bench Subsystem



◆ Key Specifications

- Photonics Industries Laser Parameters
 - Divergence range 0.4 to 1.5 mR
 - Beam diameter range 1.5 to 2.0 mm
 - Maximum laser energy 2.5 mJ @ 532 nm
- Transmit path optical transmission > 90.8%
- Transmit Divergence out of the Telescope
 - 6 – 30 arcseconds full angle
- Point Ahead – GTA out of the Telescope
 - Satellite 0 – 11 arcseconds beam angular displacement in any direction
 - Planetary 0 – 60 arcseconds beam angular displacement in any direction
- Receive path optical transmission 77% (night) 54% (day)
- Receiver FOV from the Telescope
 - 14 to 60 arcseconds
- Star Camera FOV from the Telescope
 - 2 arcminute FOV
 - Spot size 2 arcseconds (Covers ~10 pixels)



Optical Bench Subsystem

Inter-Subsystem ICD



- ◆ Slide removed due to export control regulations



Optical Bench Subsystem Design Diagram



- ◆ Slide removed due to export control regulations



Optical Bench Subsystem



- ◆ Status of build
 - Procuring long lead items
 - Procuring test hardware and instrumentation
- ◆ Location of activity
 - GSFC / Building 28, W120G
 - GSFC / GGAO
 - KBRwyle
 - Sigma Space



Optical Bench Subsystem



- ◆ Path forward/work left to be done
 - Create component and subsystem acceptance test plan and procedures
 - Procure remaining components
 - Perform component testing
 - Complete optical/motorized assemblies and test
 - Populate optical bench with components/assemblies and align optics
 - Integrate test laser and test receiver with the Optical Bench Subsystem
 - Test and characterize as a subsystem
 - Deliver Optical Bench Subsystem to SGSLR facility



METEOROLOGICAL SUBSYSTEM

Design Lead: Alice Nelson

Additional details can
be found in EPR slides
and ICD document



Meteorological Subsystem



- ◆ Purpose of subsystem
 - Measures environmental conditions to support ranging and system health & safety



Meteorological Subsystem



◆ Key Specifications

- Barometric Pressure Measurement
 - Range: 500 to 1100 hPa
 - Accuracy: ± 0.08 hPa
- Temperature Measurement
 - Range: -40°C to $+60^{\circ}\text{C}$
 - Accuracy: $\pm 0.1^{\circ}\text{C}$
- Humidity Measurement
 - Range: 0 to 100% non-condensing
 - Accuracy: $\pm 2\%$ at 25°C
- Precipitation:
 - Device measures multiple types of precipitation: rain, freezing rain, fog, haze (dust, smoke, sand) and clear conditions
 - Precipitation detection sensitivity: 0.05 mm/h or less, within 10 minutes
 - Intensity Measurement Range: 0.00 – 999 mm/h



Meteorological Subsystem



◆ Key Specifications

- Wind Speed Measurement
 - Range: 0 – 75 m/s
 - Accuracy: ± 0.1 m/s or 2% of reading (*whichever is greater*)
 - Resolution: 0.01 m/s
- Wind Direction Measurement Range: 0 - 360°
 - Accuracy: $\pm 2^\circ$
 - Resolution: 0.01°
- Sky Camera
 - Field of View: $180^\circ \times 180^\circ$
 - Pixel Scale: 5.4 arcmin/pixel
- Temperature Range for Operation/Survival
 - Operating Temperature: -40°C to $+50^\circ\text{C}$
 - Survival Temperature: -40°C to $+50^\circ\text{C}$



Meteorological Subsystem Inter-Subsystem ICD



- ◆ Slide removed due to export control regulations



Meteorological Subsystem Design Diagram



- ◆ Slide removed due to export control regulations



Meteorological Subsystem



◆ Status of build

- Developing component acceptance test plan and procedures (laboratory and field)
- Most of the components have been procured
- Initial component testing in progress (laboratory and field)

◆ Location of activity

- KBRwyle
- GSFC / GGAO





Meteorological Subsystem



- ◆ Path forward/work left to be done
 - Purchase remaining components and supporting hardware
 - Write subsystem acceptance test plan and procedures
 - Complete the characterization and testing of each component
 - Mount components for outdoor testing as a subsystem
 - Test and characterize as a subsystem
 - Deliver Meteorological Subsystem to SGSLR facility

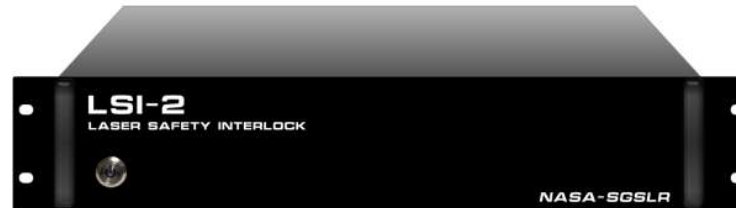
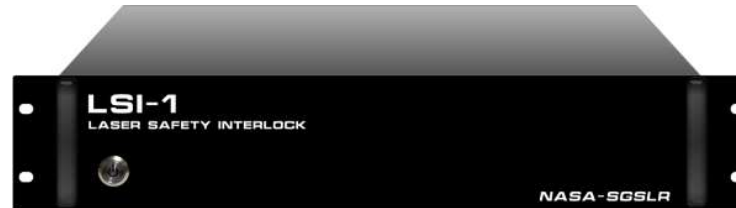

LASER SAFETY SUBSYSTEM

Design Lead: Donald Patterson





Laser Safety Subsystem



◆ Purpose of subsystem

— Laser Safety Interlock (LSI)

- Provide a means of operating an outdoor laser system in a safe manner as prescribed under NASA, ANSI, FAA and Local Safety Standards
- Protect personnel from harmful exposure to laser light inside or outside the SGSLR shelter
- Prevent the transmitted beam from striking an aircraft

— Laser Hazard Reduction System (LHRS)

- Provide a means of detecting an aircraft before it intersects with a transmitted laser beam



Laser Safety Subsystem



◆ Key Specifications

— LSI

- Failsafe & Redundant
- Multiple Safety Sensor Inputs (Footpads, Door Sensors, Laser Kill Switches, etc.)
- Reaction time
 - Laser Fire Disable ~50 ms

— LHRS (radar)

- Transmit Frequency 9410 MHz
- Transmit Power 25 W
- Range 45 km for a 20 sq-m target
- Drive Rate
 - Azimuth 20°/second
 - Elevation 20°/second
- Pointing Accuracy $\pm 0.05^\circ$
- Dish diameter 48"
- Repetition Rate 1000 Hz
- Pulse
 - Pulse length 40 ns
 - Chirp length 2-96 μ s



Laser Safety Subsystem



◆ Key Features

- Fails Safe Design/Implementation
- Co-aligned and directly slaved to the telescope and gimbal
 - Constantly monitors airspace in direction of laser energy
- Radar power level monitored
- Radar pedestal level monitor
- Cable interfaces
- Watchdog timers used for μ P operations
- Redundancy
 - Laser Trigger Inhibit
 - Beam Blocks/Optical Attenuators
- Weekly LHRS and LI verification
 - Check individual interlocks (door, pressure pads, buttons)
 - Verify radar detection off of ground target
 - Verify beam block operation



Laser Safety Subsystem Inter-Subsystem ICD



- ◆ Slide removed due to export control regulations



Laser Safety Subsystem Design Diagram



- ◆ Slide removed due to export control regulations



Laser Safety Subsystem

LSI Design Details

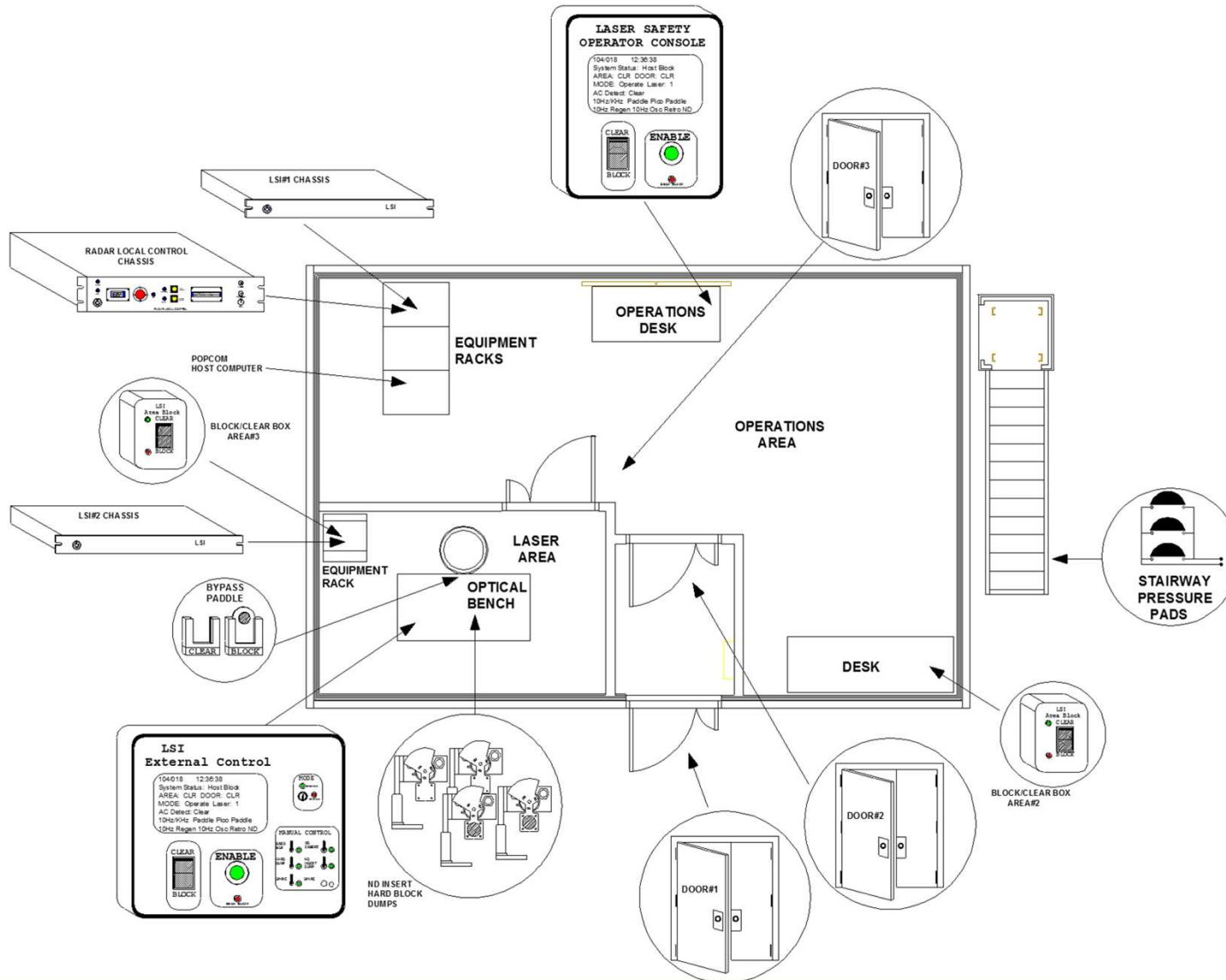



Laser Safety Subsystem

LSI Design Details

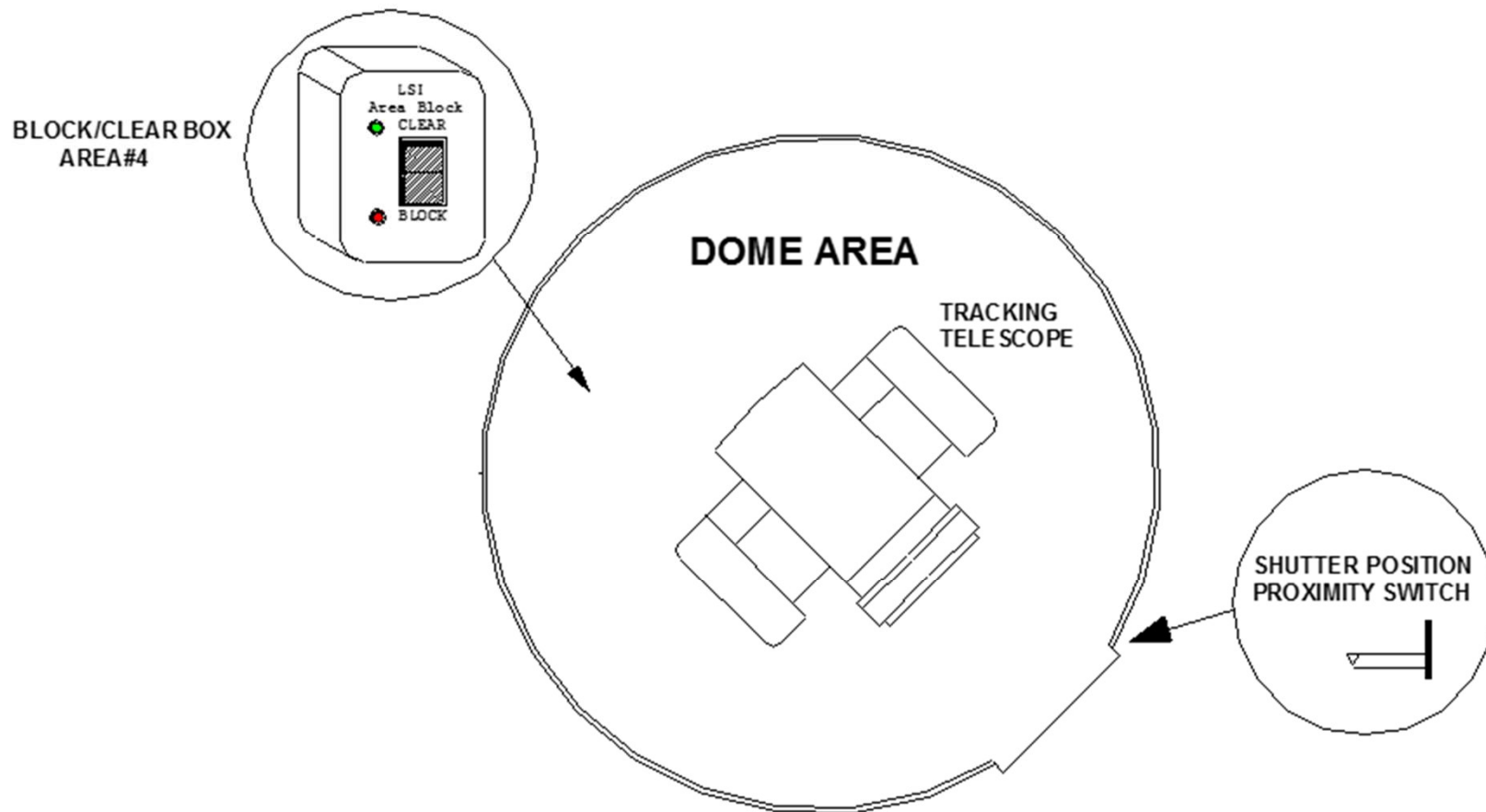



Laser Safety Subsystem

LSI Design Details

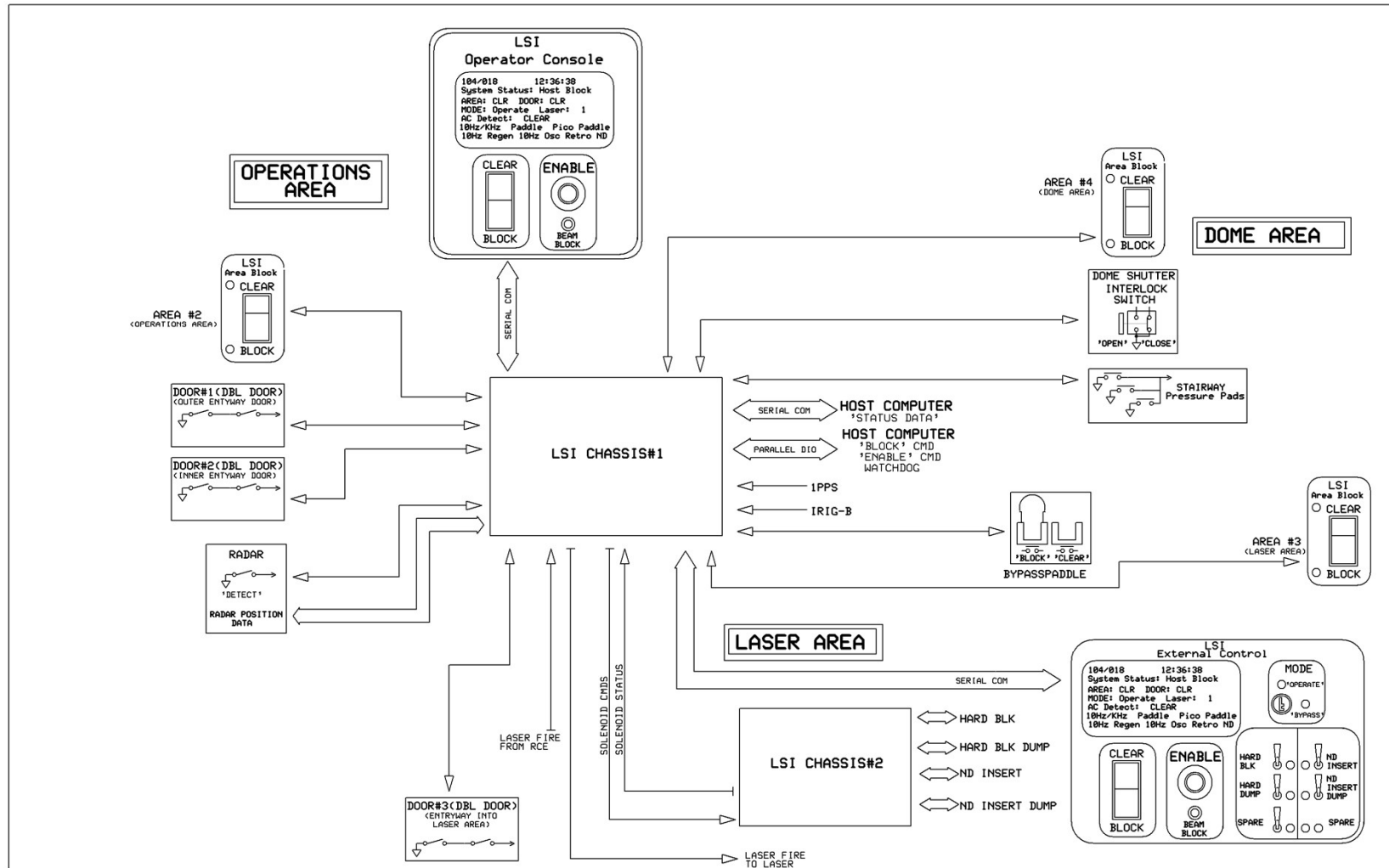

SGSLR LSI BLOCK DIAGRAM
 C:\LSC2018\CDR\EXPRESCHBLK\DWG6202018.SCH
 Rev L.0
 6/27/2018 SHEET#1



Laser Safety Subsystem



◆ Status of build

— LSI

- Parts ordered and being received
- PCBs designed and fabricated, being stuffed
- Machine hardware on order
- Design document complete

— LHRS

- Pedestal design complete
- Pedestal prototype built and undergoing test
- Solid state radar scheme complete
- Solid state radar transceiver purchased and undergoing test

◆ Location of activity

- KBRwyle
- GSFC / GGAO





Laser Safety Subsystem



- ◆ Path forward/work left to be done
 - Conduct LSS subsystem review
 - Write subsystem acceptance test plan and procedures
 - Complete initial component testing
 - Complete the build of the subsystem
 - Test and characterize subsystem
 - Deliver Laser Safety Subsystem to SGSLR facility



Additional details can be found in EPR slides and ICD document

LASER SUBSYSTEM

Design Lead: Howard Donovan





Laser Subsystem



- ◆ Purpose of subsystem
 - Provides stable, narrow pulse width, 532 nm laser pulses used for ranging operations
 - Externally triggered at varying frequencies of 1887 Hz – 2000 Hz (500 – 530 μ s between shots)

- ◆ Subsystem consists of 2 physical packages:
 - Combined laser head/electronics
 - Chiller providing water cooling to laser optics



Laser Subsystem



◆ Key Specifications

- Wavelength 532 nm
- Pulse Energy 2.5 mJ
- Average Power 5.0 W
- Beam Divergence < 1 mR
- Beam Diameter 1.7 mm
- Pulse Width 50 ps
- Repetition Rate Single Shot to 5 kHz
- Spatial Mode TEM₀₀
- Pulse to Pulse Stability < 2% RMS
- Long Term Stability < 2 % (8h ±3°C)
- Beam pointing Stability < 50 μRad

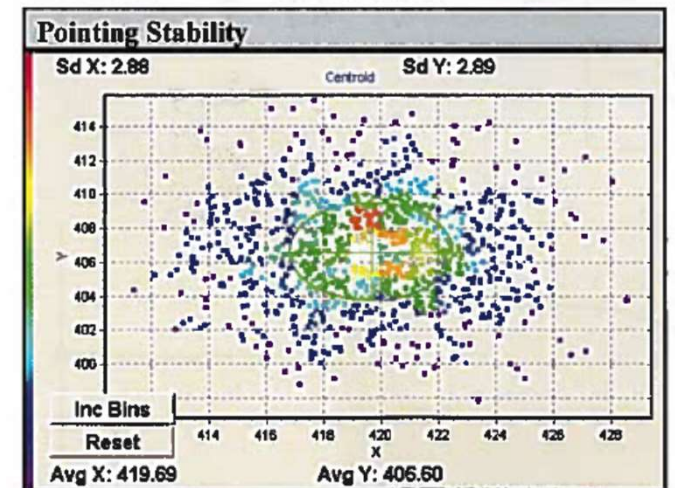
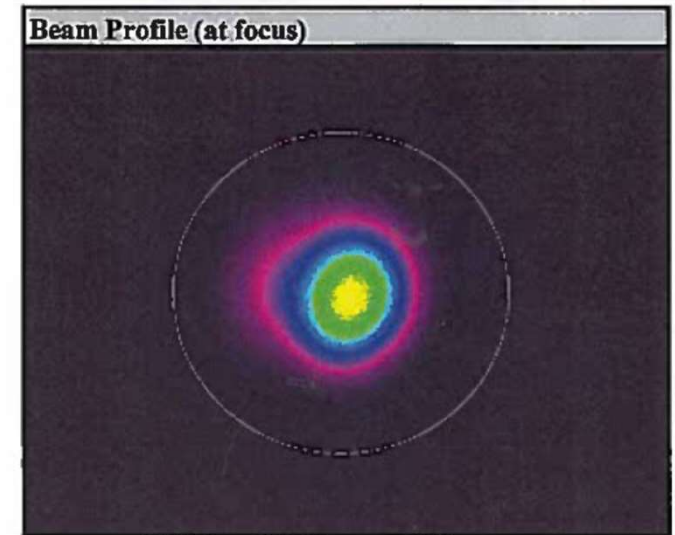



Laser Subsystem Inter-Subsystem ICD



- ◆ Slide removed due to export control regulations



Laser Subsystem Design Diagram



- ◆ Slide removed due to export control regulations



Laser Subsystem



◆ Status of build

- COTS product procured
- Initial checkout test performed at KBRwyle
- Lab currently being set up in GSFC / Building 28, W120G
- Developed laser safety plan for the lab

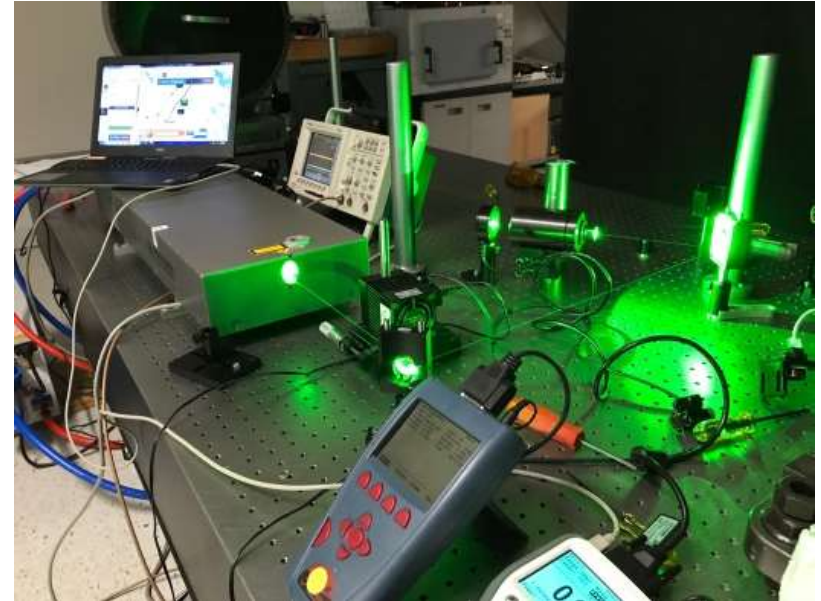

◆ Location of activity

- GSFC
 - GGAO
 - Building 28, W120G

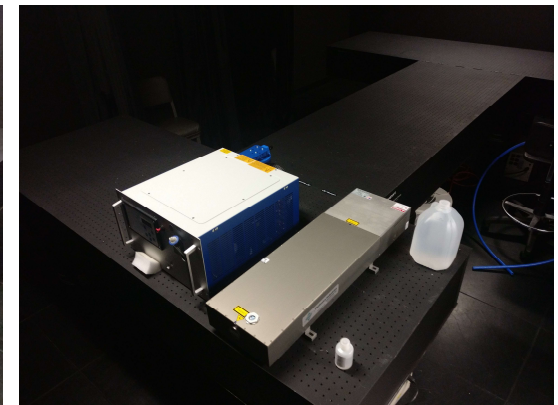
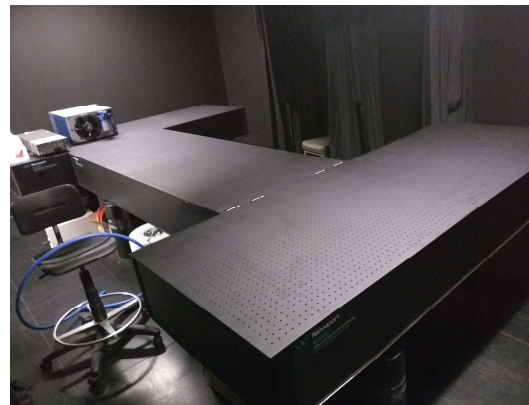



Laser Subsystem



- ◆ Path forward/work left to be done
 - Modify existing laser subsystem acceptance test plan and procedures
 - Acquire laser safety plan approval for GSFC / Building 28, W120G
 - Complete the characterization and testing of laser including long term performance testing
 - Deliver Laser Subsystem to SGSLR facility



Additional details can
be found in EPR slides
and ICD document

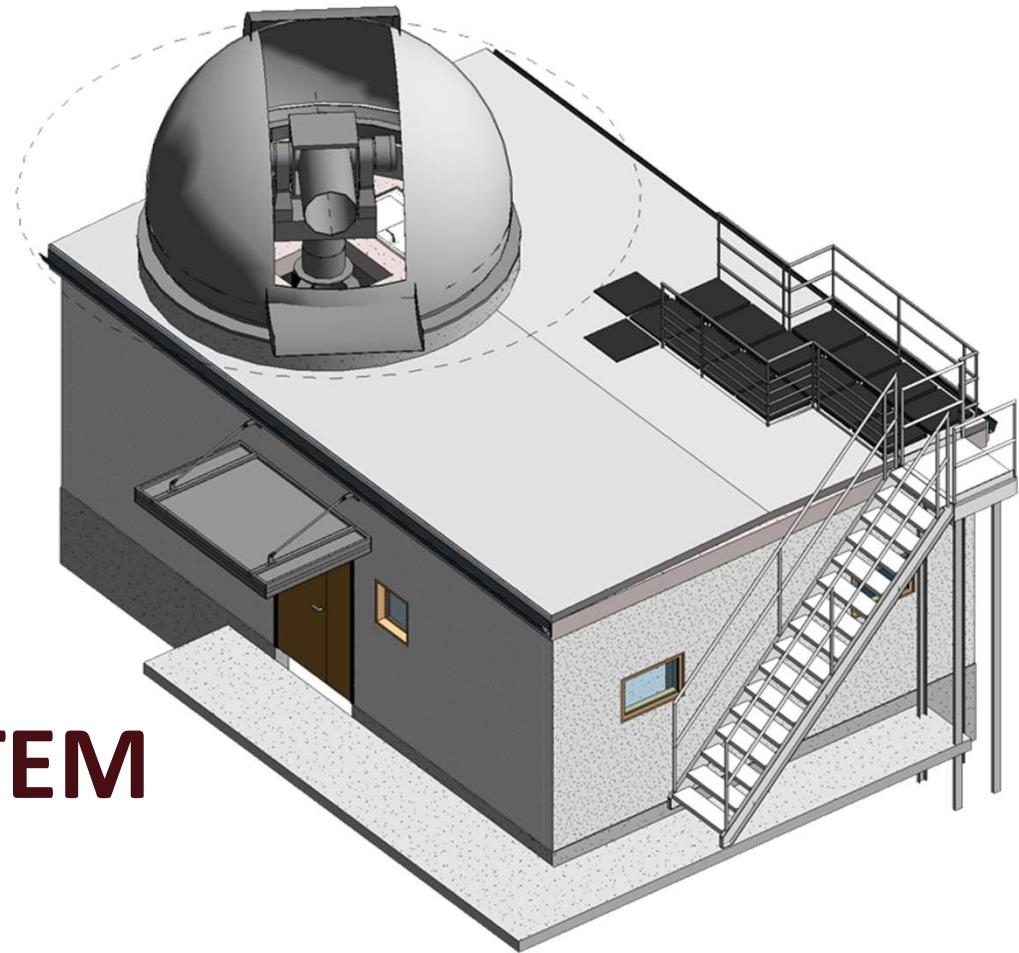

DSPR SUBSYSTEM

Design Lead: Alice Nelson

DOME, SHELTER, PIER AND RISER SUBSYSTEM



DSPR Subsystem



◆ Key Specifications

- Dome
 - ~ 4 meter diameter
 - Supports work inside dome during bad weather
- Shelter
 - COTS prefabricated concrete building
 - 20' wide x 30' long x 10' high
 - Partitioned into three areas (Vestibule, Operations, Laser)
- Pier
 - Steel reinforced concrete, single pour
 - ~ 3' in diameter cylinder on top of a stable foundation
 - No direct contact between the pier and the shelter (vibration isolation)

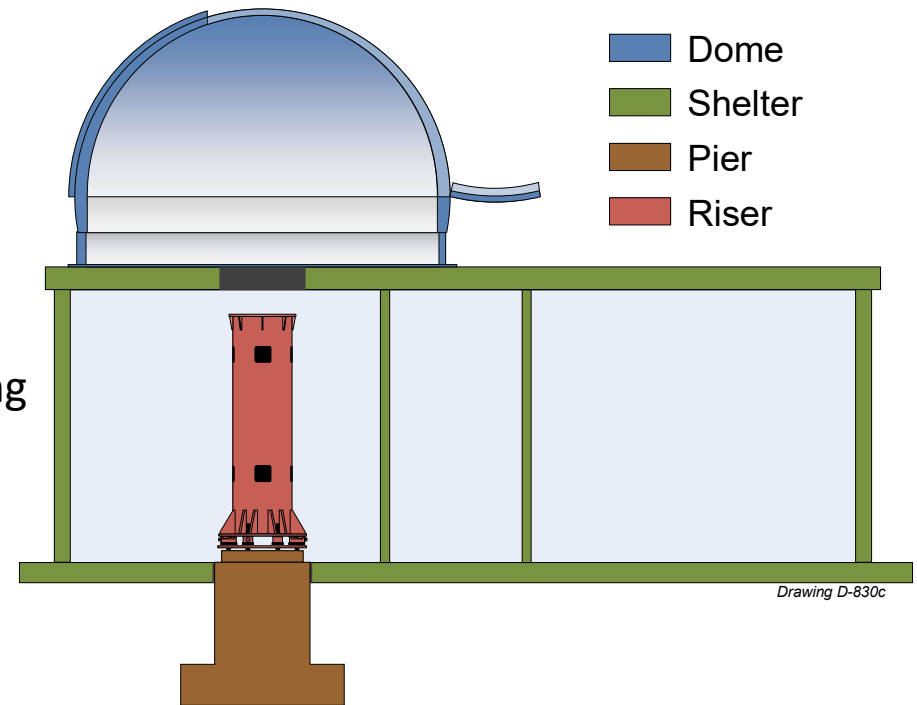

- Riser
 - 1 meter in diameter by 2 meters in height



DSPR Subsystem



◆ Purpose of subsystem

- Provides stable structural support
- Distributes conditioned power to other subsystems
- Provides a conditioned environment for equipment within the shelter
- Dome protects Telescope and Gimbal from the elements
 - Rain, snow, sleet, dust, sand, etc.
 - High wind conditions
 - Reduces wind buffeting during tracking
 - Protects GTA from solar loading
- Provides vibrational isolation for the optical components
- Riser serves as the optical interface between the telescope and the optical bench



DSPR Subsystem Inter-Subsystem ICD



- ◆ Slide removed due to export control regulations



DSPR Subsystem Design Diagram



- ◆ Slide removed due to export control regulations



Simplified Power and Grounding

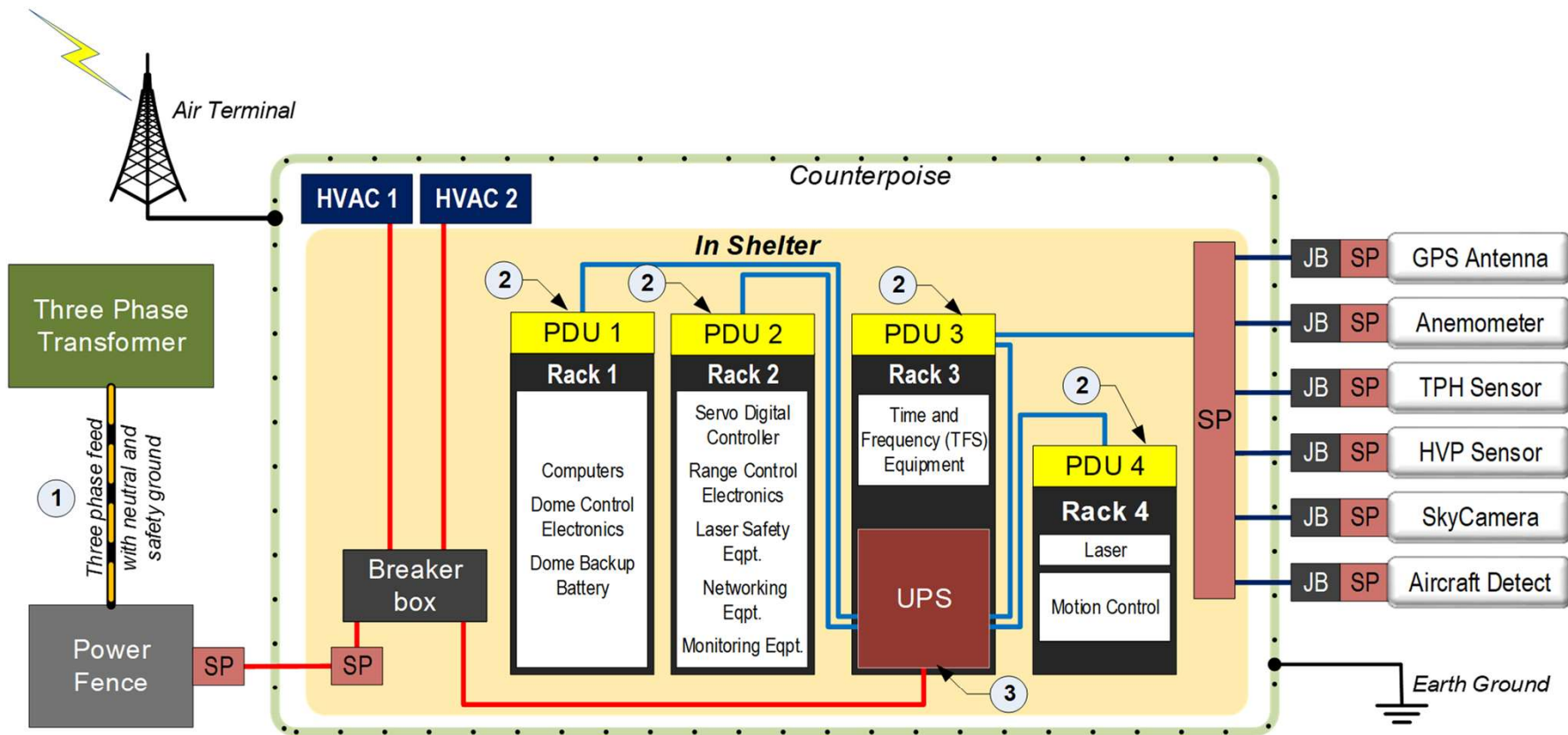

DRAWING NOTES

- 1 Five wire, three phase feed (A, B, C) system with neutral and ground isolated back to the transformer.
- 2 PDU units are used to provide, monitor and control (ON/OFF) power.
- 3 UPS unit is used to provide, monitor and control (ON/OFF) conditioned power.

KEY

	Counterpoise (leads to ground field)		Electrical Junction Box
	Three phase feed (5 wire)		Surge Protection
	Three phase (5 wire)		Uninterruptable Power Supply
	Single phase		Power Distribution Unit
	Conditioned single phase		

Drawing D-828a



DSPR Subsystem



◆ Status of build

- Implementing design at GGAO and MGO
- Consulting with NMA to modify existing shelter at Ny-Ålesund to satisfy requirements for SGSLR

◆ Location of activity

- GSFC / GGAO
- MGO
- NGO
 - Unique configuration built by NMA

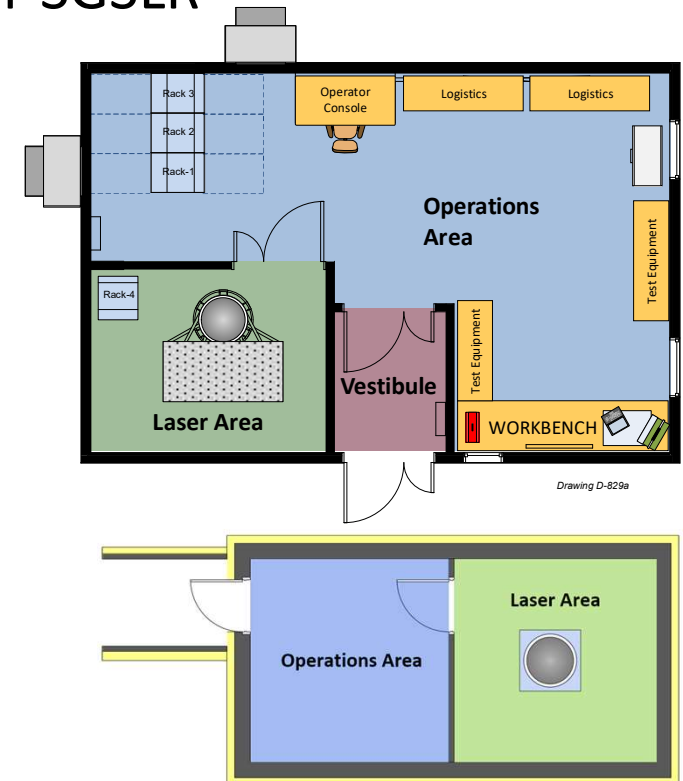



DSPR Subsystem



- ◆ Path forward/work left to be done
 - Write subsystem acceptance test plan and procedures
 - Prepare site, pour concrete for pier and shelter foundation
 - GSFC / GGAO only
 - Construct shelter
 - GSFC / GGAO & MGO only
 - Install at all three sites
 - Riser, equipment racks, dome
 - Test and characterize subsystem (at all 3 sites)
 - Deliver DSPR subsystem to:
 - NASA for GSFC / GGAO and MGO
 - NMA for NGO



RECEIVER SUBSYSTEM

Design Lead: Evan Hoffman



Receiver Subsystem



◆ Purpose of subsystem

- SigmaSpace Receiver (SSRx)
 - Detects and time tags start (transmit) and stop (receive) ranging events
 - Precisely relates ranging events and ancillary signals to UTC
- Range Control Electronics (RCE)
 - **Generate** a gate that 'windows' a Satellite OR Calibration (Ground/Internal) corner cube return for sensor detection in the Receiver Subsystem
 - **Generate** a 'Laser Fire' Command signal BUT not at the same time a window signal appears



Receiver Subsystem



SSRx Key Specifications

- ◆ 7x7 MCP-PMT Detector Array
 - 1.6 mm Pixel size
 - <1 kHz noise per pixel
 - High QE
 - Negligible dead space
- ◆ Sigma Space Timer Card
 - 52 Channels with single shot precision of 3.45 ps
 - 45 multi-stop event channels
 - Dead time per channel (ns)
 - 45 stop event channels 3.39
 - Laser Fire < 60
 - 1 PPS from GPS < 60
 - 1 PPS from Maser < 60
 - Range Gate Start < 60
 - Spare Fire < 60
 - Spare Detector 3.39
 - Spare 1 PPS < 60

RCE Key Specifications

- ◆ Range Window (RW)
 - Delay Range 4 nsec. to 500 msec.
 - Window Width 4 nsec. to 10 μ sec.
 - Dual Output TTL, 50 Ohm BNC
- ◆ Range Window/Window (W/W)
 - W/W Centered on RW
 - W/W Width Based on RW
 - Dual Output TTL, 50 Ohm BNC
- ◆ Laser Fire
 - Pulse Repetition Interval (PRI)
 - 500, 500.5, 501, 502, 504, 510, 520, 530 μ sec.
 - Pulse Width 10 μ sec.
 - Dual Output TTL, 50 Ohm BNC
- ◆ Blanking
 - Selectable 100 nsec. - 100 μ sec. before/after start diode



Receiver Subsystem Inter-Subsystem ICD



- ◆ Slide removed due to export control regulations



Receiver Subsystem Design Diagram



- ◆ Slide removed due to export control regulations



RCE Flow Diagram

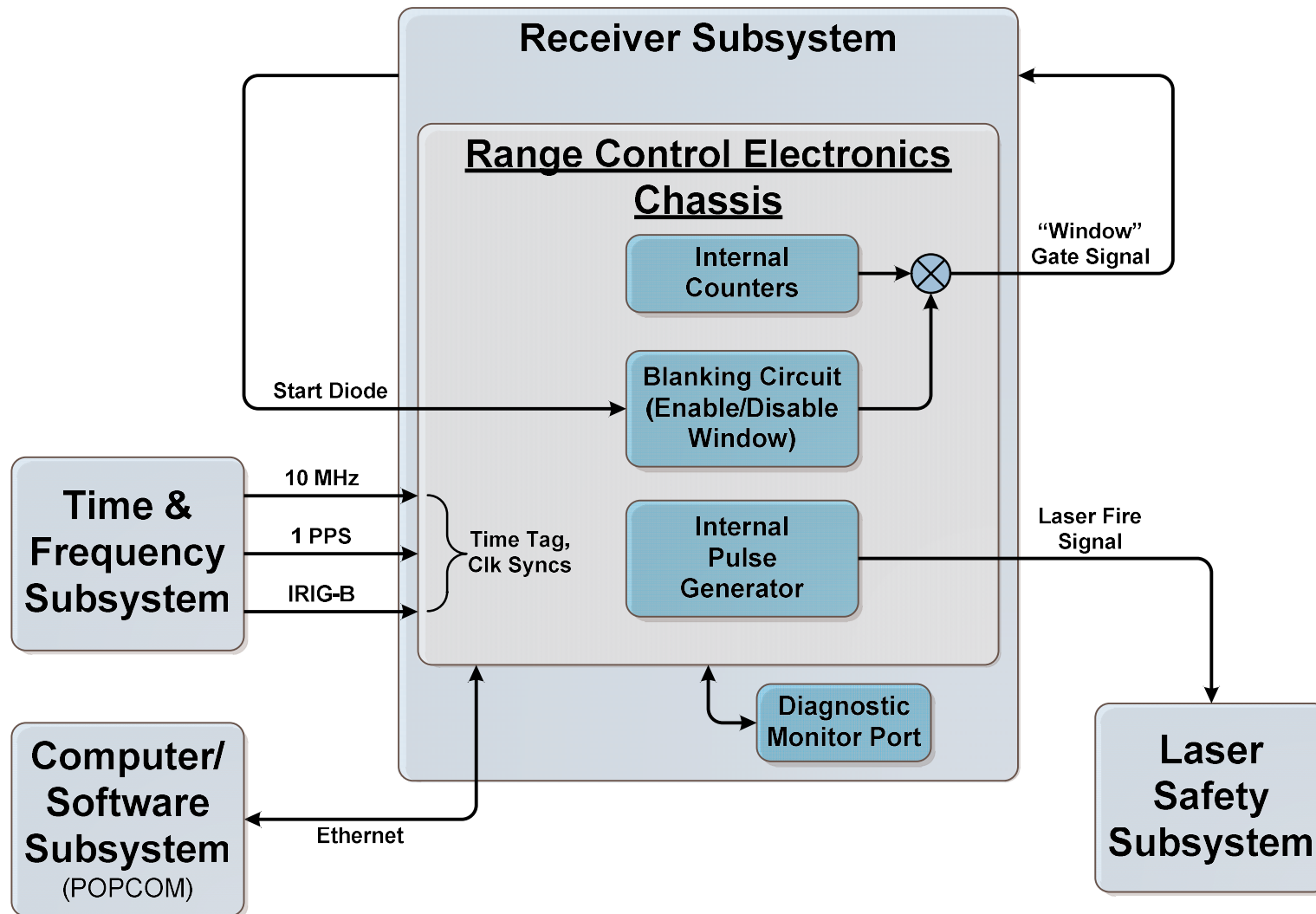



SGSLR SSRx Block Diagram



- ◆ Slide removed due to export control regulations



SGSLR SSRx Overview



- Provide Closed Loop Tracking
 - 7x7 pixelated detector array
 - 4 pixels in corners unused
 - Count # of events in each pixel to determine satellite location
 - Signal location used by C&S subsystem to correct angular position to maximize return signal strength
- Make Precise, High Resolution Timing Measurements
 - Start Events: Single measurement per shot
 - Stop Events: Multi-stop, low dead-time
 - Ancillary Events (e.g., 1 PPS)
- Selection based on proven heritage hardware from aircraft and space-flight designs

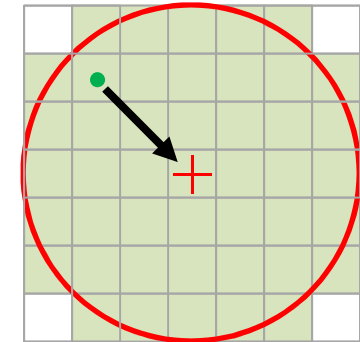



Determining Pointing Error and Eliminating Noise - 7x7 Array

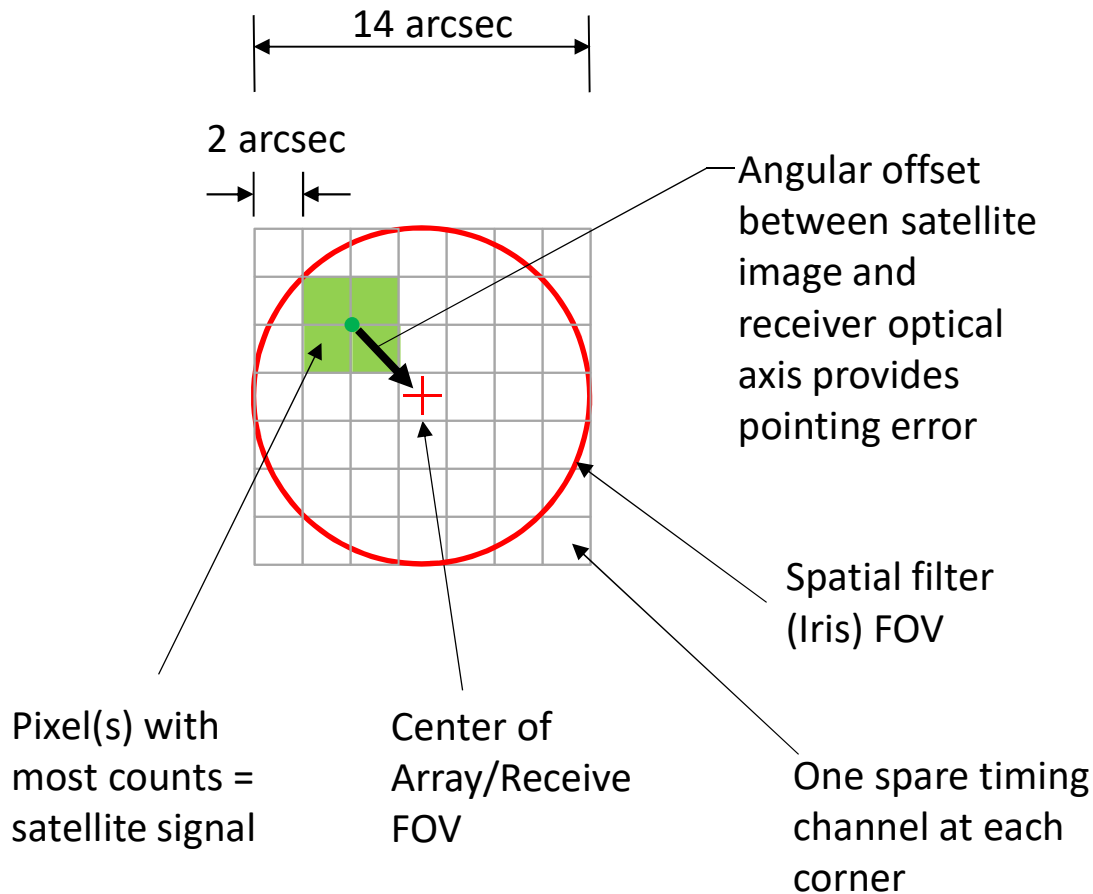

Since noise is distributed uniformly over the entire pixel array, and 4 corner pixels may see some signal, this implies that at least 41 of 45 pixels, or 91% of the noise counts can be discarded, thereby greatly reducing the potential for noise induced range bias errors in weak links.



MCP-PMT Performance Validation



MCP-PMT with constant fraction discrimination configuration tested at 1.2 Meter facility at GGAO, ranging to real ground target

- ◆ Repeatable stability to within 1 mm for 2 minute normal points, over periods greater than 1 hour (Requirement SLBP3.2)
- ◆ Stability within 1 mm for return rates 3%-18% (amplitude independence)

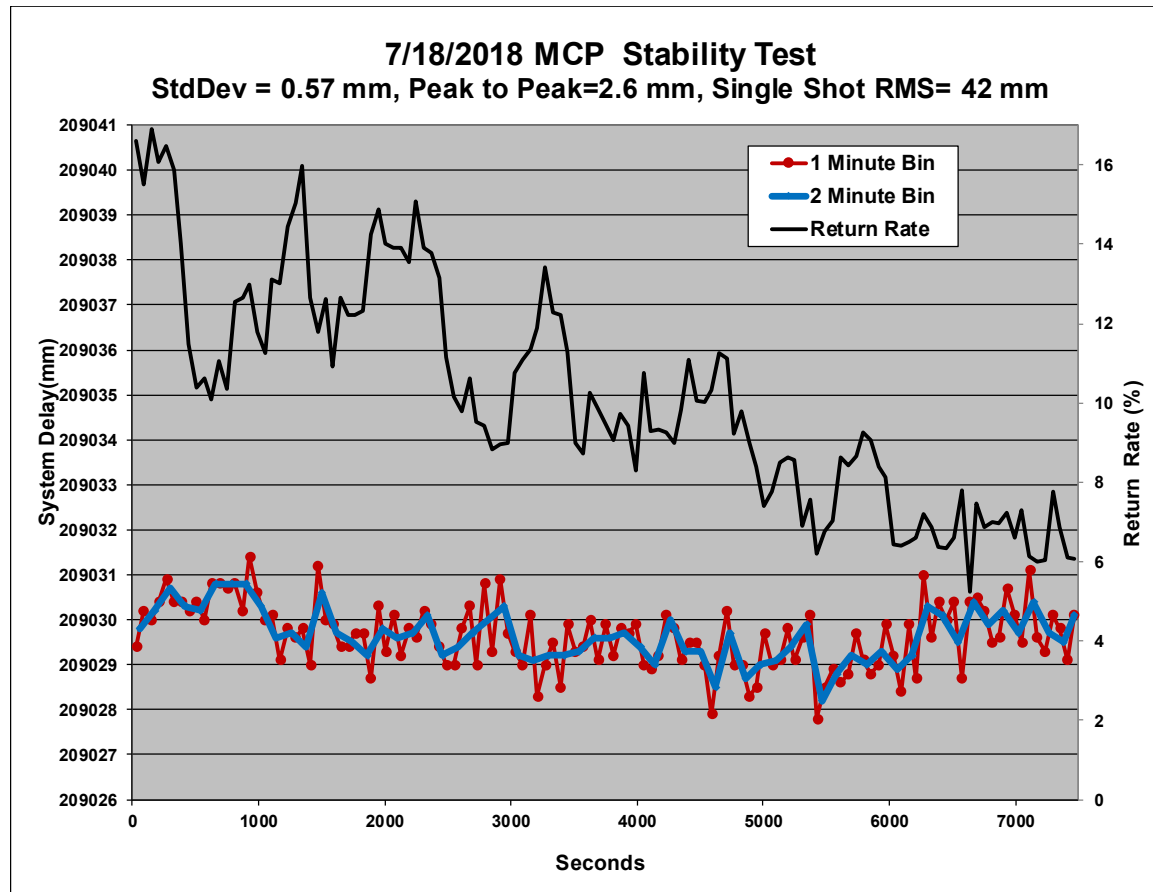

The MCP-PMT detector with CF discrimination meets stability requirements



Sigma Space Timer Performance Validation



- ◆ Sigma Space Timer tested with electronic signals for long term range measurement stability
 - Data analyzed using peak to peak difference in the means of two minute intervals over an hour. Hour intervals processed using 2 minute sliding window over 24 hours.
 - Mean of the peak to peak differences is 4.0 ps with a standard deviation of 1.9 ps.

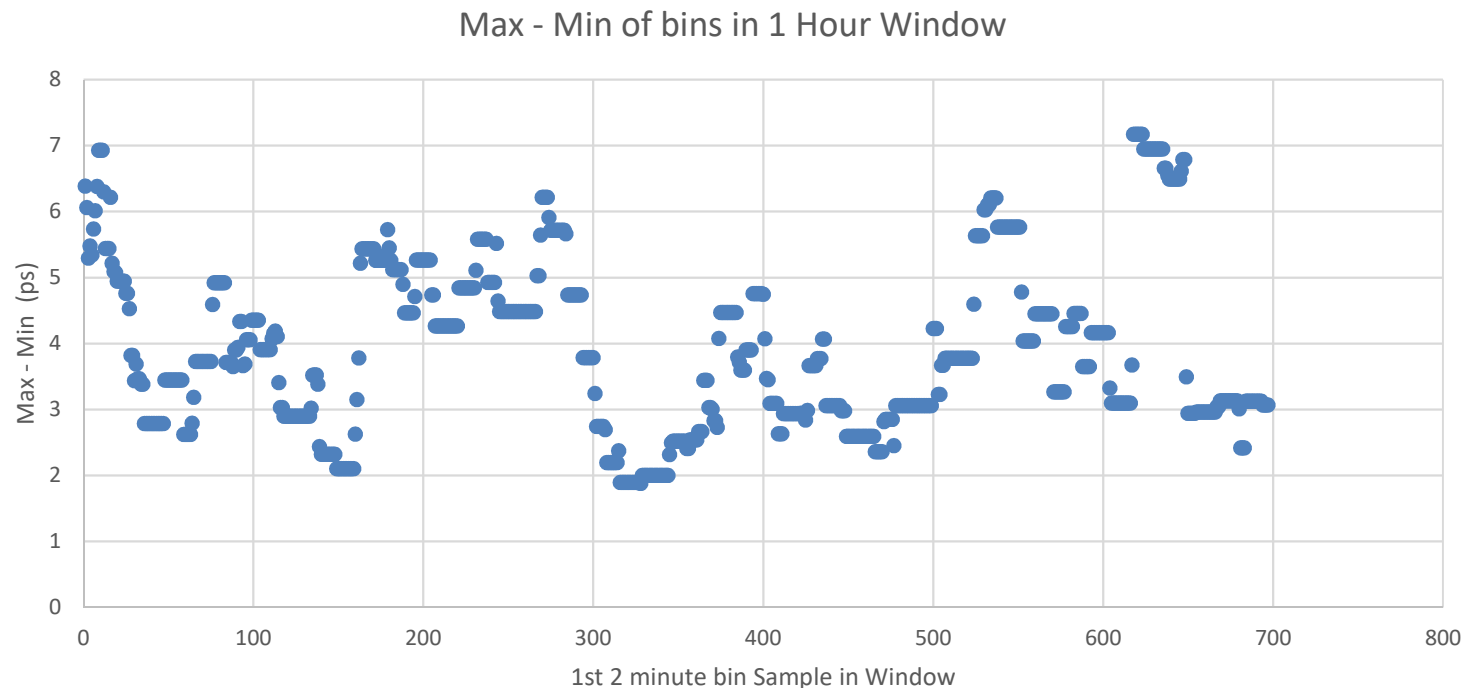

The Sigma Space Timer performs extremely well within calibration intervals



Receiver Subsystem



- ◆ Status of build
 - RCE has successfully completed EPR
 - Prototype RCE has been assembled and is undergoing testing
 - Prototype SSRx has been assembled and is undergoing testing
- ◆ Location of activity
 - GSFC / GGAO
 - KBRwyle
 - Sigma Space

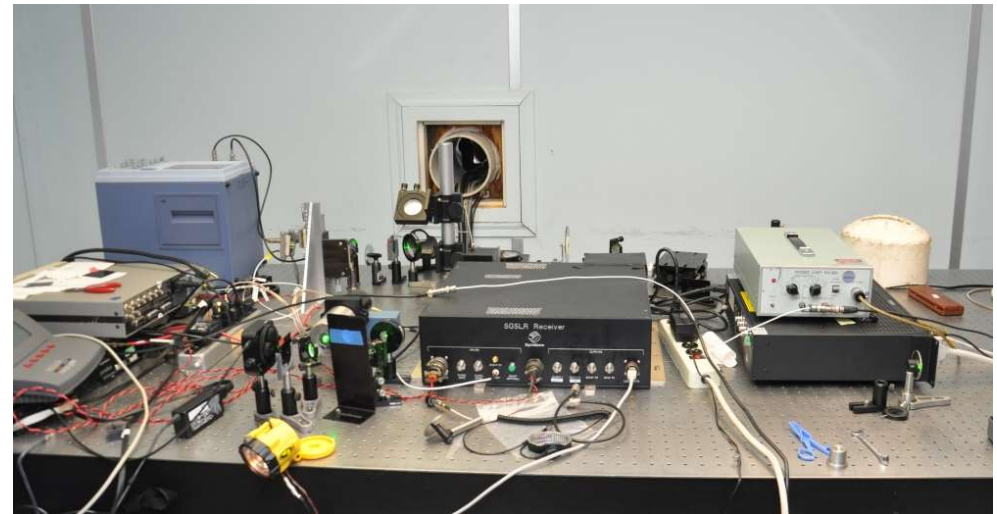
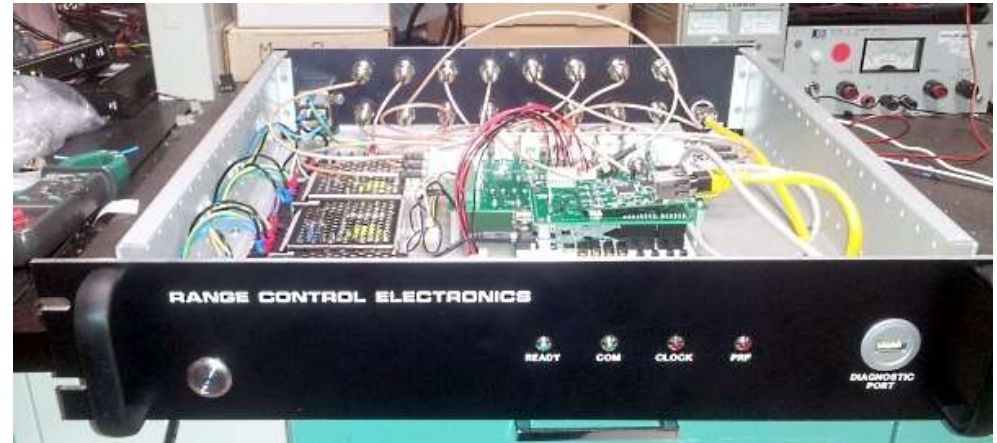



Receiver Subsystem



- ◆ Path forward/work left to be done
 - Conduct SSRx part of Receiver subsystem review
 - Write subsystem acceptance test plan and procedures
 - Finish construction of receiver field unit
 - Conduct laboratory tests on RCE and move to the SW lab
 - Conduct test and characterization of SSRx
 - Deliver Receiver Subsystem to SGSLR facility



Additional details can be found in Software Design Document and ICD



001101010011010011001010100110

COMPUTER AND SOFTWARE SUBSYSTEM

Design Lead: Jack Cheek



Computer and Software Subsystem



- ◆ Purpose of subsystem
 - Support local and remote operations
 - Command/control, calibrate, and monitor the system
 - Link all other subsystems together
 - Transfer and store data, process ranging data, perform operational decision making, generate and deliver science data product, and communicate with the SGNOC
 - System Automation



Computer and Software Subsystem Inter-Subsystem ICD



- ◆ Slide removed due to export control regulations



Computer and Software Subsystem Design Diagram



- ◆ Slide removed due to export control regulations



Software Main Functions

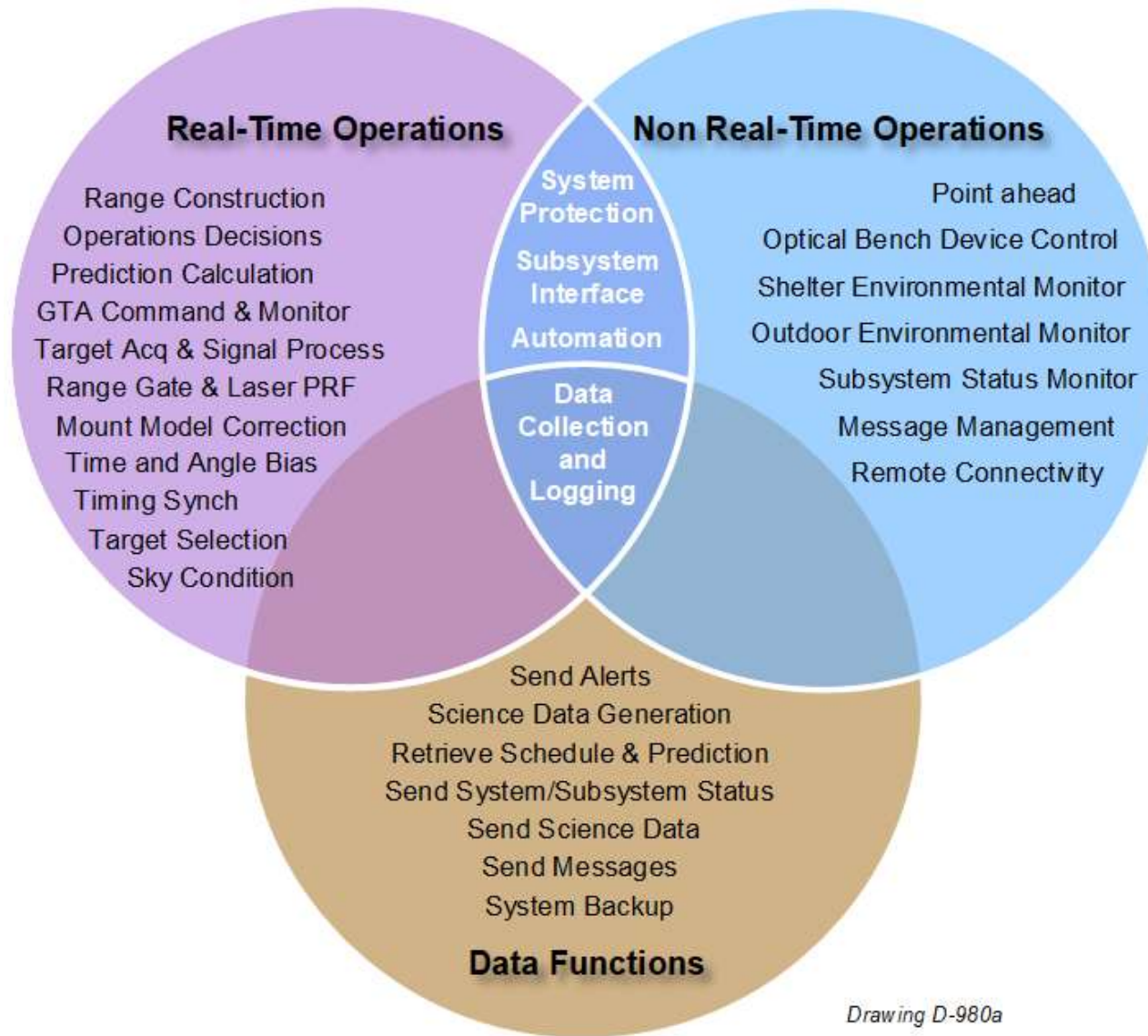

Drawing D-980a



Software Design / Main Functions



DAM

Optical Bench Device Commanding

- Risy Prisms
- Beam Expander
- ND Filters
- FOV device
- Iris device
- Daylight filters
- Shutters

Message Handling
Remote Access Management
Meteorological Data Collection
Hardware and Environmental Monitoring
System and subsystem safety and health monitoring
Laser Configuration

Linux

LOCAL/REMOTE

RAT

System Interface

- Monitoring
- Operational Control
- Troubleshooting

Linux

VIRTUAL MACHINE

CAMERA

Sky clarity (All Sky Camera)
Centroid calculation (Star Camera)
Laser monitoring

- Beam Profiler
- Power Meter

CNS Clock configuration

Windows 10

POPCOM

Operational Decision Making

- Target Selection
- Target Acquisition and Signal Identification
- Time and Angle Bias
- Meteorological Conditions

Data Collection and Logging
Raw Data Formation
Time Interrupt Handling
Dome and Shutter Control
Mount Model Correction
GTA Commanding and Monitoring
Receiver Commanding and Monitoring
Range Gate & Laser PRF Determination

Linux (Realtime)

ANA

Data Processing
Prediction and Schedule Retrieving
Science Data Generation and Delivery

Linux

ADMIN

System Backup
IT Security Logging

Linux

KEY

- Computer
- Software Function
- Grouping as listed

Drawing D-981a



Software Development and Management



- ◆ SGSLR team will provide software development and management from the Computer and Software Laboratory at the GGAO in Building 208 Rm E.
 - The laboratory contains 3 full system computer configurations
 - Development / Test / Operational Configuration
 - Laboratory is designed for development and testing and includes SW simulators/ HW engineering test units / HW prototypes
 - Regular system backup

- ◆ The SGSLR software will use multiple methods to ensure robustness:
 - Software design written with requirements traceability
 - Code walkthroughs
 - Maintain design documentation and design changes
 - Software design verification – Computer and Software Subsystem Review
 - Software Test Plans (modular level, functional level, system level) written with requirements traceability
 - Maintain developer’s testing notes
 - Record and track discrepancy reports
 - Document all testing reports



Software Development and Management



- ◆ Software development Tools
 - Code analyzer, logic analyzer, etc.
 - Software configuration management and version control
 - Implement Software auditing tools to ensure system integrity
- ◆ Software Configuration Management
 - SGSLR is using GIT for version control
 - Flexible
 - Recommended by Goddard project managers
 - Ability to use local and/or centralized based version control
 - Development phase using local version control
 - Integration phase and beyond will use centralized based version control
- ◆ Discrepancy Reporting
 - Bugzilla
 - Web based Database of discrepancy reports available to all developers and testers
 - Ease of use



Computer and Software Testing



◆ SGSLR Software Testing

- The software will go through developer, module and subsystem / system level testing.
- The Software builds will be integrated and tested with each subsystem as described in the Software Build Plan.
- The SGSLR Software Testing will ensure that selected software packages meet their specified requirements.
 - The implementation of each software package will be verified to the requirement
 - Will provide and maintain bidirectional traceability from the Software Test Plan to the software requirements
- The SGSLR test team is comprised of the SGSLR software team and several hardware developers
- No SGSLR software developer will module test or subsystem test the software that they develop



Software Test Flow

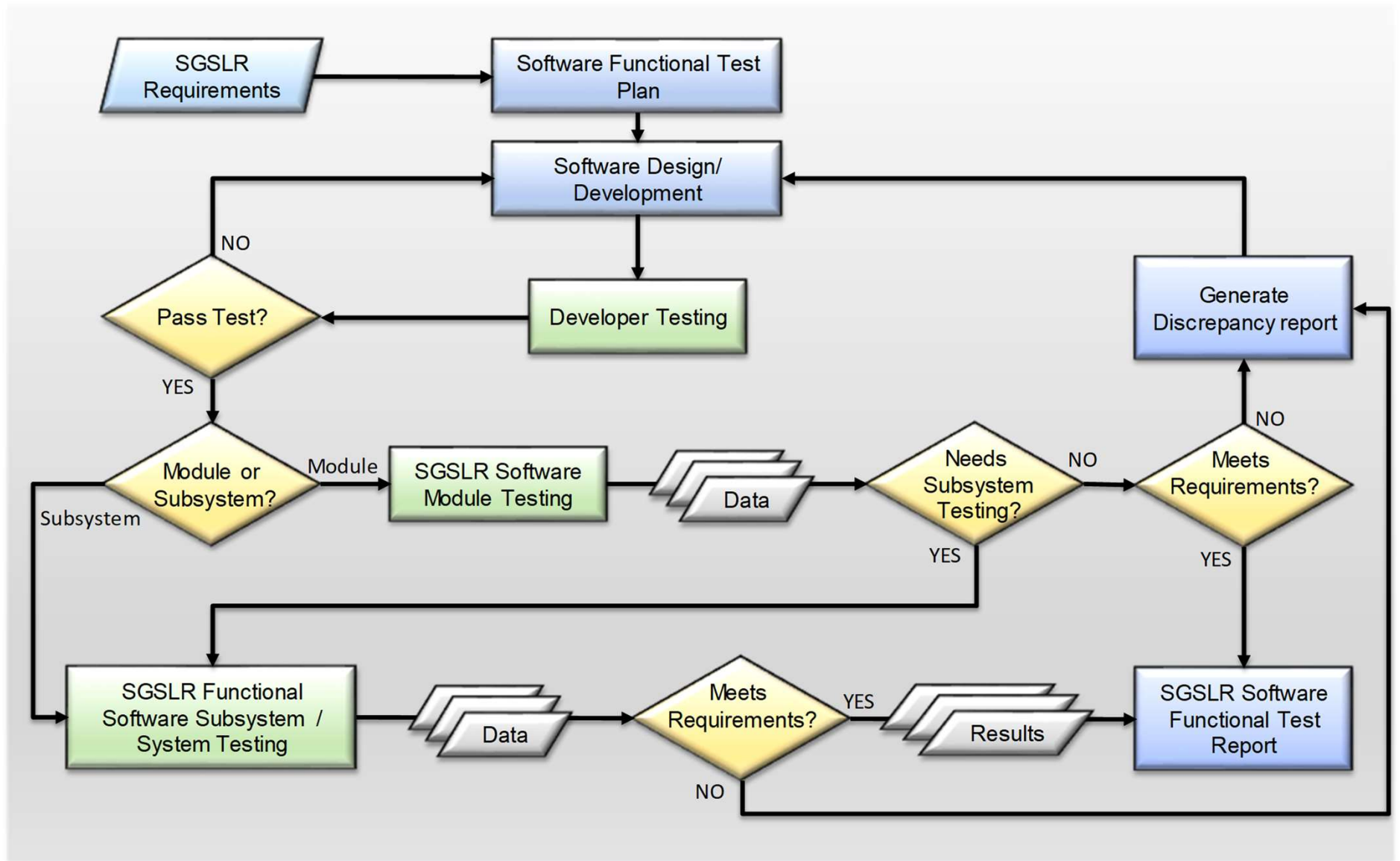



System Implementation Approach



◆ Phased Approach

- System I&T Phase
 - OS LTS version freeze – Security patches as required
 - Software updates as needed
 - Strict Configuration Control and communication process
- System Verification Phase
 - OS/Software freeze
 - Capture configuration changes for post-verification
- System Commissioning Phase
 - Software updates as needed
 - Updated through the SGNOC
 - Routine OS patches/updates – every 3 months
 - Images pushed and installed through the SGNOC
- System Maintenance Phase
 - Routine OS patches and software updates – every 3 months
 - Images pushed and installed through the SGNOC
 - Critical OS patches as needed



Build and Release Plan (1)



SGSLR Software Build and Release Plan			
Build	Target	Schedule	Functionality
0	Software Baseline	Feb-17	Prototype computer hardware, Real-Time OS, Shared Memory Stub, BC635 Timing Card, MET Interface, Timing Interface to BC635 card
0.1	MET and Timing HW Prototype Build	Build 0.0 + 6 months	POP software stub, DAVROS stub, RATGUI stub, Ratsnest stub, Shared Memory, Gimbal simulator, Timing HW Prototype installed in lab
0.2	GTA Test Software / Pre-FAT Build	Gimbal HW - 2 months	MET, Timing, Star simulator, GTA Simulator, Gimbal HW control and interface; Remote Access Terminal gimbal control; RATSNEST, Camera Computer
0.3	GTA Test Software / GTA FAT, SAT Build	Dome + GTA HW - 2 months	MET, Timing, Star Calibration Software, GTA HW, Dome control and interface; Remote Access Terminal RATGUI gimbal control; RATSNEST; Target selection based on a schedule for sunlit satellites; Camera Computer; SBIG star camera
0.4	Post GTA FAT, SAT Build	GTA SAT + 3 months	MET, Timing, Star Calibration Software, GTA HW, Dome control and interface; Remote Access Terminal RATGUI gimbal control; Camera Computer; SBIG star camera. Lessons learned from FAT / SAT and software optimizations; Add DAM computer with Metarchive and RATSNEST

Currently working on Build 0.3



Build and Release Plan (2)



SGSLR Software Build and Release Plan			
Build	Target	Schedule	Functionality
0.5	Operational Software Build #1	RCE Prototype, LSI Prototype, Receiver Simulator + 8 months	Operational Software Configuration Baseline; Previous Build software; RCE Interface software; Receiver simulator; rsync; NGSRLR post-processing; move to final reflective memory; Backup scheme; starting virtualization
0.6	Operational Software Build #2	Shelter, Optical Bench Prototype, OB Chassis HW Prototype, Receiver + 6 months	OB prototype, Optical Bench HW (beam expander, Risley Prisms, ND wheel, star camera, receiver shutter); LSI interface, DAM DAVROS, Laser Interface; Early Message Center; Virtualization of camera and ANA
1	Operational / Collocation Software Build and Release	System Integration + 6 months	Operational Software Configuration integrated, interfaced and tested with all Subsystems; preliminary closed loop tracking
1.1	Post Collocation Software / Pre-Shipment Review Build and Release	Collocation + 2 months	Incremental updates and modification for lessons learned from Collocation; Improvements to Closed Loop Tracking; Improvements to message center

First Operational Software Release



Internet Communications



- ◆ Internet capability for SGSLR at each site is expected to be 1 Gb/s.
- ◆ Allocation of data rate and data volume for SGSLR:
 - Volume: 500 Gb/day which is factor of 2 margin
 - Max data rate: 7 Mb/s is ~ 35% of margin
 - Calculation includes:

Raw Logx Ranging Data

Science Data

Engineering Data

Subsystem Status and
Monitoring Information

System Status Information

Remote Access Terminal
Communication

Backups and software
(including OS) upgrades

Still Pictures and Limited
Video

- ◆ Additional video cameras for security are being studied which will increase the max rate allocation, but probably not volume allocation.



SGSLR IT Security



- ◆ The software team along with a network engineer has designed an architecture which fully addresses IT security utilizing:
 - Two-factor authentication for logins
 - NASA VPN
 - Virtual Networks (VLAN)

- ◆ We will adhere to the following documents:
 - NASA NPR 1620.3A – Physical Security Requirements for NASA Facilities and Property
 - NASA NPR 2810.1A – Security of Information Technology
 - Standards for Security Categorization of Federal Information and Information Systems, Federal Information Processing Standards Publication 199
 - Minimum Security Requirements for Federal Information and Information Systems, Federal Information Processing Standards Publication 200

- ◆ This is addressed further in the Network Architecture section



Backup Plan



- ◆ Full and incremental computer backups will occur on a regular basis at all operational stations on the SGSLR Admin computer
 - Incremental (data) backups will occur once per day and kept onsite
 - IT Security logs (selected IT Security logs will be streamed to SGNOC real-time)
 - Configuration files
 - Raw / Processed data
 - Incremental (data) backups will be sent to the SGNOC once a week
 - Full system backups will occur and kept on the system and sent to SGNOC once a month
- ◆ Backups will occur by partition so as not to disturb data that is unique to each site.
- ◆ Scheduling is being investigated to see what impact this will have on the system operations



Computer and Software Subsystem



◆ Status of build

- Test Software developed for initial GTA testing used at Cobham, Clearwater, FL - August 2017
- Operational test software developed for use at the Cobham GTA pre-FAT utilizing timing hardware and a GTA simulator (Build 0.2)
 - Testing successfully completed with the operational test software and the actual SGSLR GTA at Cobham Lansdale, PA - August 2018
- Working on Operational test software for GTA FAT/SAT (Build 0.3)

◆ Location (of activity)

- GSFC / GGAO Software Development Lab in Building 208, Room 8E
- Cobham – FAT Testing
- GGAO / SGSLR – SAT Testing, Integration and Test, Verification
- MGO, Texas – SAT Testing
- NGO, Norway – subset of SAT Testing



Computer and Software Path Forward



- ◆ Hold Computer and Software subsystem review
- ◆ Complete Software Test Plan and procedures
- ◆ Integrate new ranging design into the operational software
- ◆ Integrate the interfaces for new hardware
- ◆ Test the software in SW lab with simulators and/or engineering test units for all hardware components
- ◆ Deliver initial operational Computer and Software Subsystem to SGSLR facility for integration and collocation
- ◆ Test with subsystems at the SGSLR facility as subsystems are added during Integration and Testing



System Integration and Testing



Acceptance Testing



- ◆ All components will undergo acceptance testing when received according to the individual subsystems acceptance testing plan
- ◆ Testing will include basic functionality tests
 - Form/Fit/Function for mechanical and optical parts
 - Power on and operation for electronic / mechanisms parts



Subsystem Component Testing



- ◆ GTA – Only tested at the assembled level, not component. This is a COTS purchase.
 - Pre-FAT testing at vendor facility to prepare for FAT
 - Full specification testing at ambient at FAT and SAT
 - Analysis through modeling at various temperatures
 - Long term testing performed on Unit 1 while at GGAO
- ◆ Optical Bench
 - Optical Bench
 - Inspected for mechanical dimensions
 - Mechanisms (motion control)
 - Tested individually for control and range of motion
 - Controlled by subset of the C&S subsystem or vendor provided GUIs
 - Spacing for alignment, LSS, Laser and Receiver
 - Optical components are verified where possible through vendor testing and witness samples
 - Mechanical components – Holders, spacers, etc.
 - Inspected for dimensions, functionality



Subsystem Component Testing



◆ Receiver

- Receiver Control Electronics
 - Tested for functionality on the bench
 - Full simulated functional testing
 - Functional testing with C&S subsystem
- SigmaSpace Receiver (SSRx)
 - Laboratory testing
 - Ground target ranging at 1.2m telescope facility
 - Check ranging stability and precision
 - Stability/precision over time
 - Stability/precision over signal strength

◆ Laser Subsystem - COTS purchase, not component

- Laser characteristics
 - Energy and power, beam shape, beam divergence, cold start to specified power and stability, wavelength, intermittent start/stop w/r/t power/stability, etc.
- Long term operation
 - The above characteristics measured over time period of >1 month



Subsystem Component Testing



◆ Laser Safety Subsystem

- Test all components and sensors (foot pads, door sensors, mushroom switch, etc.)
- Test for fail-safe operations
- Aircraft detection verified through appropriate onsite testing

◆ Time and Frequency

- Measure component delay/skew/output level
- Monitor/Measure Signal degradation
- Long term monitoring of components after integration for signal quality and stability

◆ Meteorological

- Long Term testing of components in laboratory and at site
- Inter-component comparison in thermal vacuum chamber (MET4a)



Subsystem Component Testing



◆ DSPR

- Dome – COTS product demonstrated at FAT
- Shelter
 - Inspections during construction
 - Shelter, lights, mechanical (temperature/humidity stability), power, etc.
- Pier
 - Inspection during construction
 - Dimensions, grounding, mounting bolts and location of bolts, isolation of pier from shelter, etc.
- Riser
 - Inspection
 - Dimensions, access port locations, top/bottom parallelism of flanges, finish, etc.



Subsystem Component Testing



◆ Computer and Software

- The computer hardware will be tested according to the acceptance plan
- The computer interface cards / hardware will be interface tested
- For each OS patch / upgrade the computer will be tested in the lab



Integration



- ◆ Systematic approach to integration:
 - GTA SAT needs MET, T&F, part of the OB, and some operational C&S components
 - Laser installation needs the OB and LSS
 - Receiver installation needs the OB
- ◆ Most subsystems integrated as a unit (all components assembled at one time and integrated)
- ◆ Some Optical Bench components are integrated with the GTA to allow for the GTA SAT testing.
- ◆ Computer and Software subsystem is integrated in stages throughout the build and is the final stage of integration of the overall system.



System Integration and Verification (1)



◆ DSPR

- Telescope Pier poured and set
- Foundation for Shelter poured and verified isolation from pier.
- Foundation for Met poured and set along with conduit to shelter
- Shelter installed
 - Shelter requirements verified
- Riser installed on Pier, leveled and Pier/Riser requirements verified
- Dome installed on shelter
 - Dome requirements are verified by combined FAT and SAT

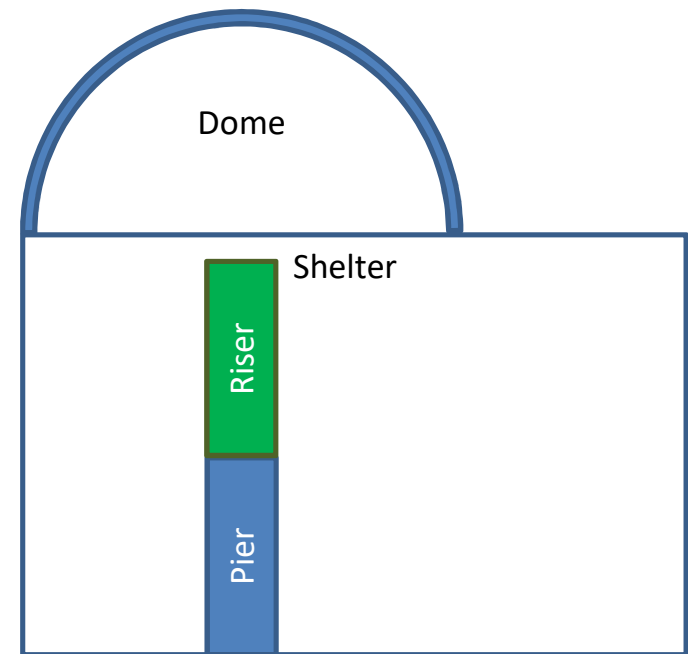



System Integration and Verification (2)



◆ Meteorological

- Instruments installed on foundations (mechanical)
 - Long term testing started
- Electrical / Fiber installed and interface with shelter verified
- Data interface with test software

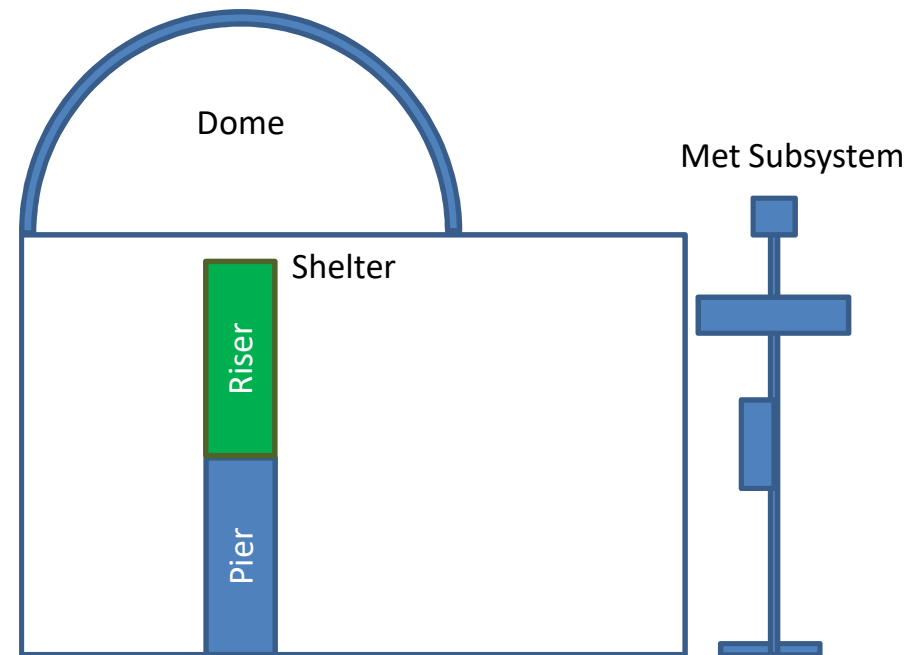



System Integration and Verification (3)



- ◆ Time and Frequency
 - Install T&F components
 - Interface with C&S
 - Delays measured to all target subsystems
- ◆ Optical Bench (partial)
 - Install optical table, GTA test configuration
- ◆ Computer and Software
 - Install computers with software (part 1)
 - Test with T&F, dome, MET, and OB (partial)

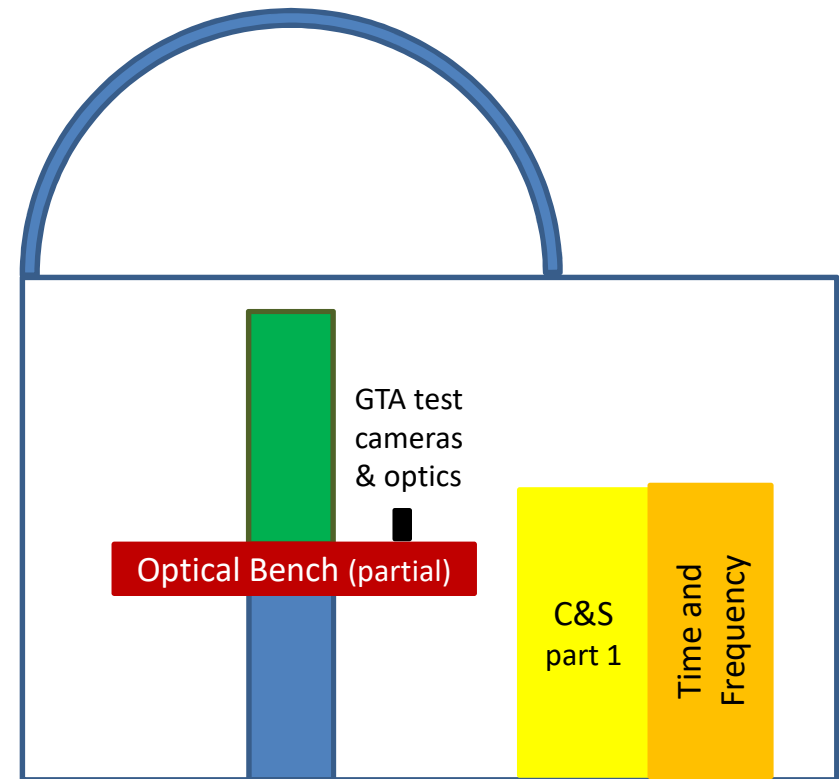

C&S Part 1 are the computers and software needed for GTA testing at GGAO.



System Integration and Verification (4)



◆ GTA

- Install mechanical interface to Riser
 - GTA thermally isolated from riser
 - GTA/DSPR requirements verified (Dome clearance, minimum elevation pointing, shutter opening, etc.)
- Install electrical interface to Shelter
- SAT testing performed
 - Subset of FAT tests
 - GTA requirements verified by combined FAT and SAT

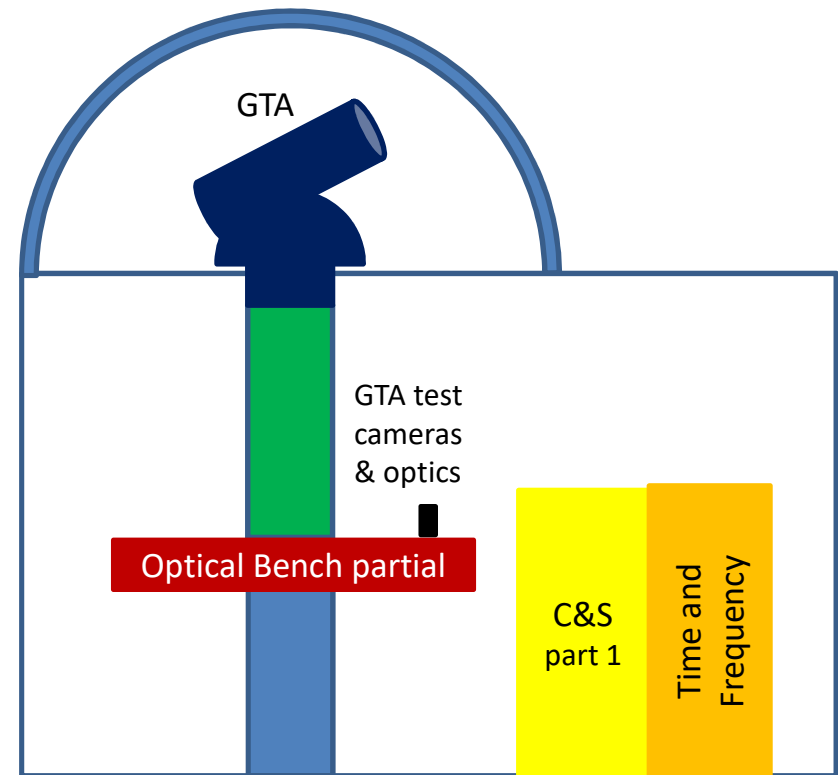

C&S Part 1 are the computers and software needed for GTA testing at GGAO.



System Integration and Verification (5)



◆ Optical Bench

- Remove GTA test cameras and optics
- Install OB components on existing optical table and align
- Install interface with C&S (software part 2)
- Align OB to GTA

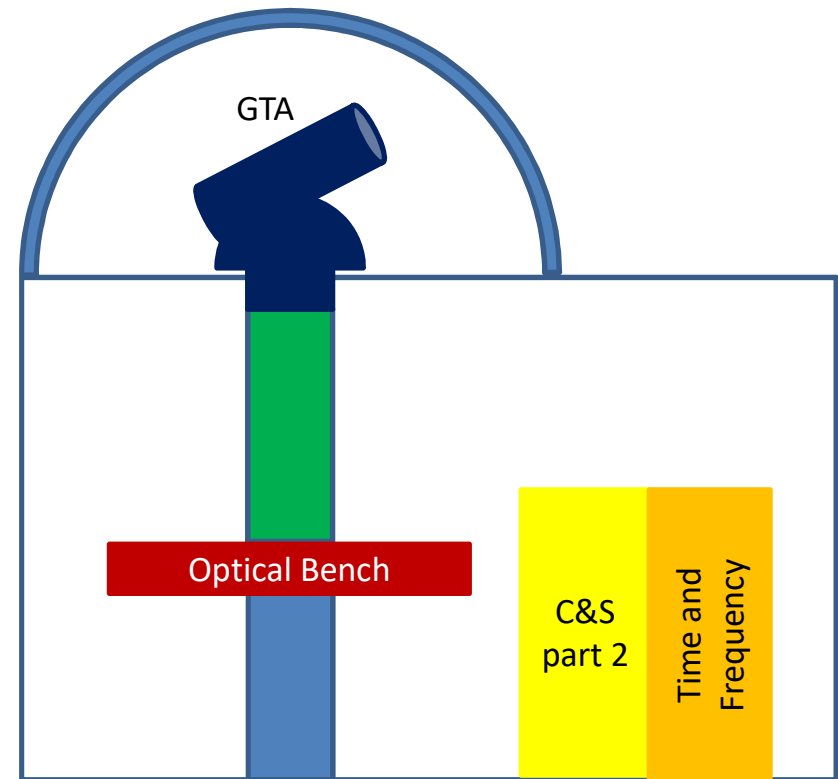

C&S Part 2 incorporates control of the OB components into C&S Part 1



System Integration and Verification (6)



◆ Laser Safety

- Install radar on MOBBLAS 7 Support Van
- Interface to C&S subsystem (software part 3)
- Install interior/exterior components installed
 - Chassis, door sensors, pressure pads, beam blocks, etc.
- Requirements verified

◆ Laser

- Install laser head and chiller
- Interface with RCE and C&S (software part 3)

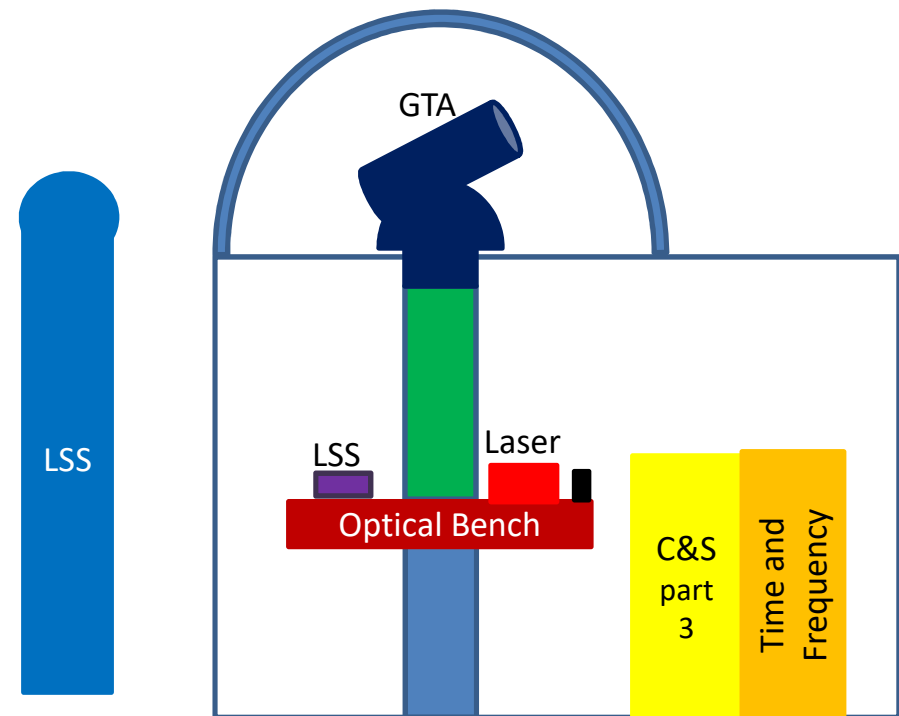

C&S Part 3 incorporates communication with the Laser Safety Subsystem and the Laser into C&S Part 2.



System Integration and Verification (7)



- ◆ Receiver
 - SSRx installed on OB (mechanical, optical, electrical)
 - RCE install (mechanical, electrical)
 - Interface between Laser and Laser Safety
 - Characterizing timing delays from Time & Frequency to SSRx/RCE
 - Data interface with C&S
- ◆ Perform full optical system alignment
 - GTA, Transmit path, Receive path, and Star Camera path
- ◆ C&S first full operational version

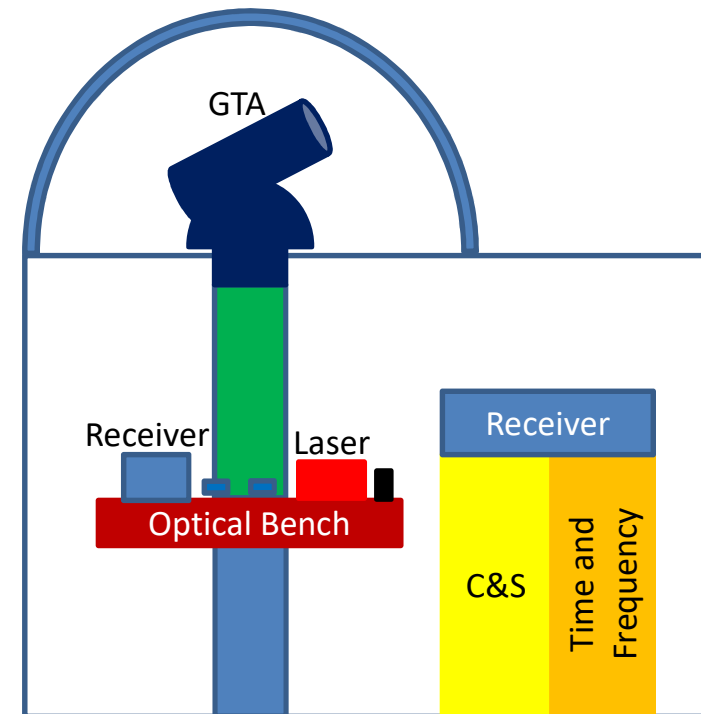

This is the first full operational C&S version that incorporates interfaces to all of the other subsystems.



System Functional Tests



- ◆ Test all modes of operation:
 - Start up / Shutdown
 - Standby / Maintenance
 - GTA velocity testing
 - GTA step response testing
 - Star calibration
 - System calibration
 - Ground target ranging
 - Minico testing
 - System stability testing
 - Satellite tracking
 - Sunlit tracking for GTA tests
 - Laser ranging to LEO, LAGEOS, GNSS

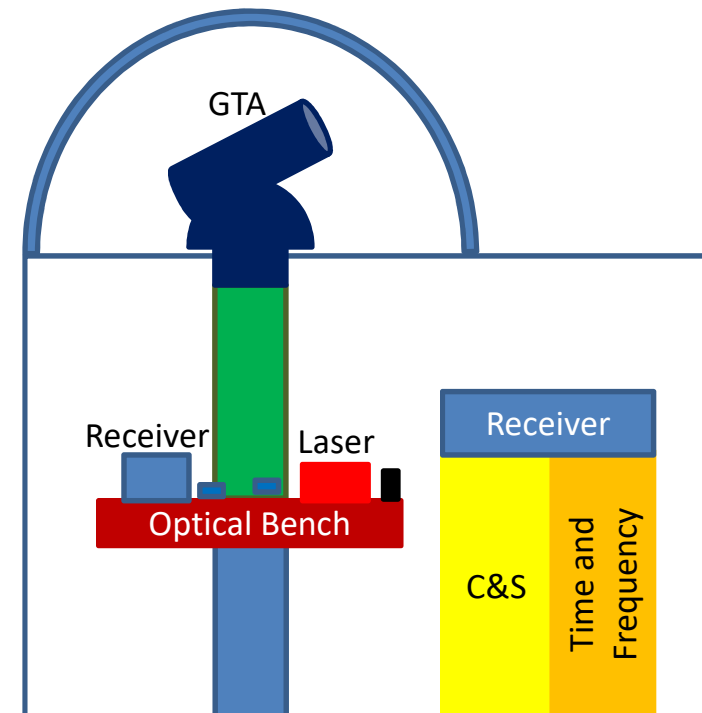



Requirements Verification



Subsystem Level Verification



- ◆ All requirements verified at highest level possible
- ◆ Requirements verified before subsystem testing
 - Design requirements like FEA for GTA, modularity of design
 - Limited access for verification like vibrational isolation of the Pier/Riser
- ◆ Requirements verified during subsystem testing
 - Critical performance requirements like Laser characteristics, T&F signals
 - Performance requirements tested during FAT for Dome or GTA
- ◆ Requirements verified during system testing
 - Anything else
- ◆ The SRD has complete list of level of verification for level 4 requirements



System Level Verification



- ◆ Four types of testing
 - Engineering Tests
 - Timing verification
 - Analysis of design
 - Safety analysis
 - Ensure required safety compliance
 - ILRS tests and inspection
 - ILRS priorities, data formats and restrictions
 - Modes of operation
 - Stand Alone and Collocation Tests
 - Ranging to Ground target
 - Ranging to Satellites
 - Ranging to Ground target with MOB7 (collocation)
 - Ranging to Satellites with MOB7 (collocation)
 - Data analysis
 - Analysis of the ranging data for system stability and precision



What is Collocation?



- ◆ SLR Collocation is a test to verify a system's performance by inter-comparison (i.e. comparing ranging data to that of a known standard).
- ◆ The test is performed by freezing each system's configuration for a period of time and comparing simultaneously tracked data.
- ◆ The known SLR network standard is MOBILAS-7 at GGAO, which has been operational for over 30 years and has been involved in many collocation tests.
- ◆ The range data is transformed from the origin of one station to the other and a direct range difference is calculated.
- ◆ The close proximity of the stations eliminates any range differences due to refraction, ground water motion, and seasonal effects. The purely geometric technique removes any discrepancies introduced by orbits.
- ◆ This analysis is an excellent engineering tool available for rapid identification of systematic error sources in a new SLR system at the few millimeter level. It has helped NASA SLR achieve uniformity and consistency of performance across its current global SLR network.

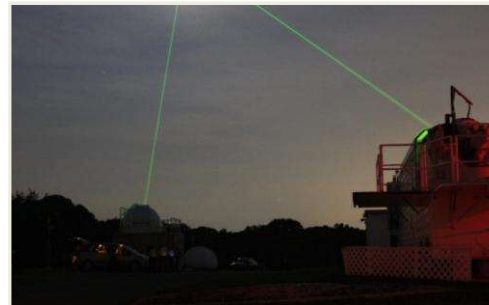



SGSLR Level 3 T&V

Collocation & Intercomparison

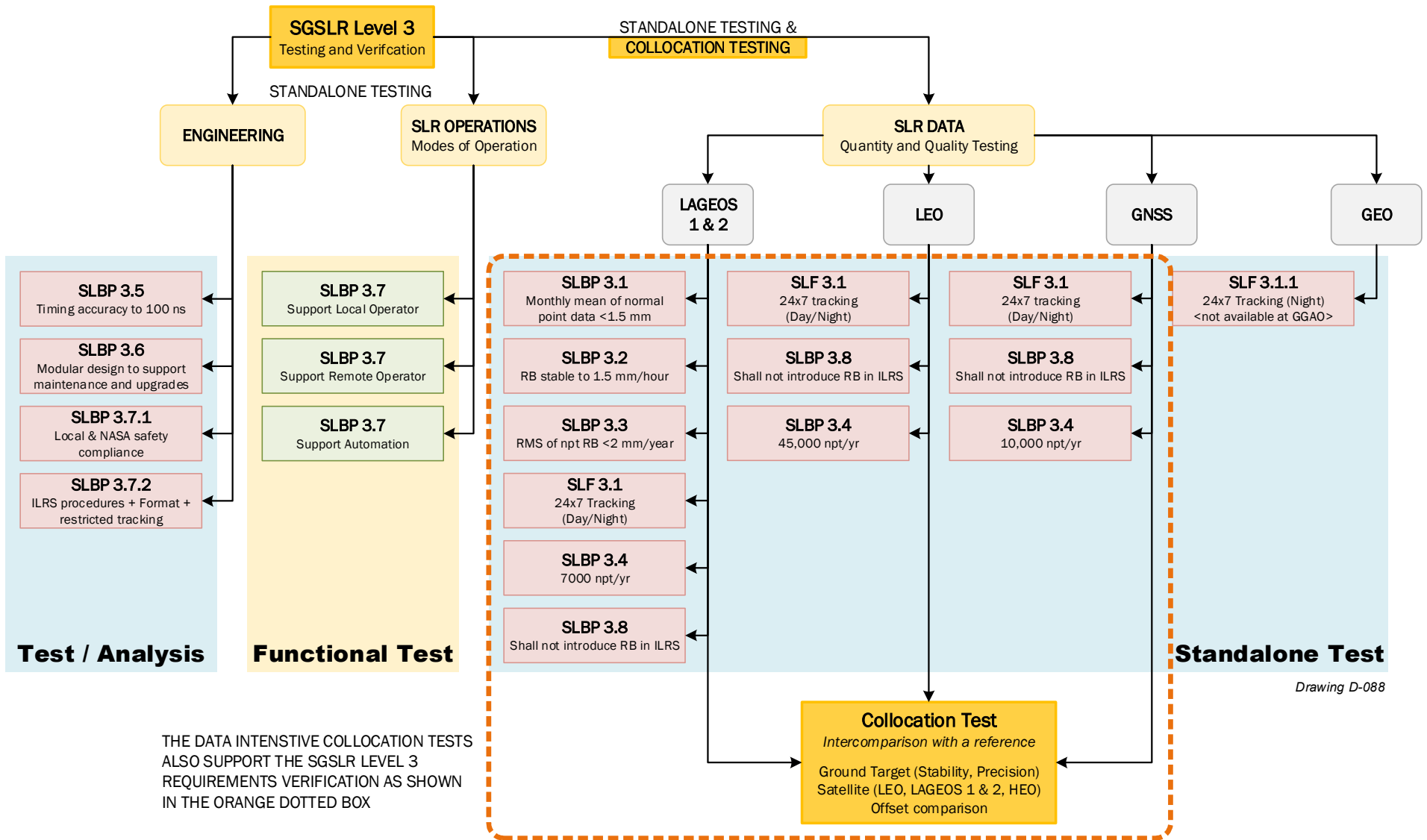



End of Day 1



Local Operations and Maintenance



General Concept of Local Operations



- ◆ Operations are run from inside SGSLR shelter
- ◆ Tracking occurs day / night
- ◆ Ground targets are ranged to every 1 to 2 hours for calibration
- ◆ Operator controls system from RAT, views whole sky with Alcor camera, and uses a camera on the GTA to view where system is pointing and for aircraft monitoring.
- ◆ Operator requests that the LSS re-enable the laser
- ◆ Software automatically follows the schedule, but operator can override
- ◆ Software determines when satellite has been acquired and applies calculated biases. Operator overrides as needed.
- ◆ Tracking data is automatically processed and sent to SGNOC within 2 hours of data collection.
- ◆ System information is regularly and automatically sent to SGNOC.
- ◆ Pointing masks protect VLBI and other ground items from getting illuminated with either laser or radar.



Modes of Operations



- ◆ SGSLR Modes of Operation:
 - Satellite Ranging (science data collection mode)
 - System Calibration
 - Star Calibration
 - Standby / Maintenance
 - Startup / Shutdown



Day-in-the-Life (DITL): MGO



System follows schedule, however operator can over-ride the schedule.

Event	Level of Automation	Time/Frequency
FAA Coordination (<i>through NASA GSFC Code 360</i>)	Manual	Once per week
Verify Laser Safety System	Manual	Once per week
System Restart (<i>mostly for computers</i>)	Automated or Manual	Start of week and when necessary
Retrieve schedule and predictions	Automated	Once or more a day
Star Calibration	Automated or Manually-initiated	As needed (~ 3 mo.)
Ground Calibration	Automated or Manually-initiated	Every 1-2 hours
Satellite Tracking	Automated or Manually-initiated	Most of the time
Inhibit laser to avoid aircraft	Automated but Operator must re-enable	As events occur
Post Processing	Automated	Every 20 minutes
Normal point & full rate data delivery	Automated	Every hour
Engineering Tests (<i>i.e. Stability and MINICO tests</i>)	Manual	Every month (<i>as needed for diag.</i>)
Software updates	Pushed from SGNOC	~ every 3 months
Local System, Software, Data Backups	Automated	Daily
Backup to SGNOC over internet	SGNOC initiated	Weekly
Daily diary of day's events sent to SGNOC	Automated	Daily



Day-in-the-Life (DITL): NGO



System follows schedule, however operator can over-ride the schedule.

Event	Level of Automation	Time/Frequency
Verify Laser Safety System	Manual	Once per week
System Restart <i>(mostly for computers)</i>	Automated or Manual	Start of week and when necessary
Retrieve schedule and predictions	Automated	Once or more a day
Star Calibration	Automated or Manually-initiated	As needed (~ 3 mo.)
Ground Calibration	Automated or Manually-initiated	Every 1-2 hours
Satellite Tracking	Automated or Manually-initiated	Most of the time
Inhibit laser to avoid aircraft	Manual from airport or by operator, or automated if LSI sensor is tripped	As events occur
Post Processing	Automated	Every 20 minutes
Normal point & full rate data delivery	Automated	Every hour
Engineering Tests <i>(i.e. Stability and MINICO tests)</i>	Manual	Every month <i>(as needed for diag.)</i>
Software updates	Pushed from SGNOC	~ every 3 months
Local System, Software, Data Backups	Automated	Daily
Backup to SGNOC over internet	SGNOC initiated	Weekly
Daily diary of day's events sent to SGNOC	Automated	Daily



Site Descriptions



SGSLR Sites

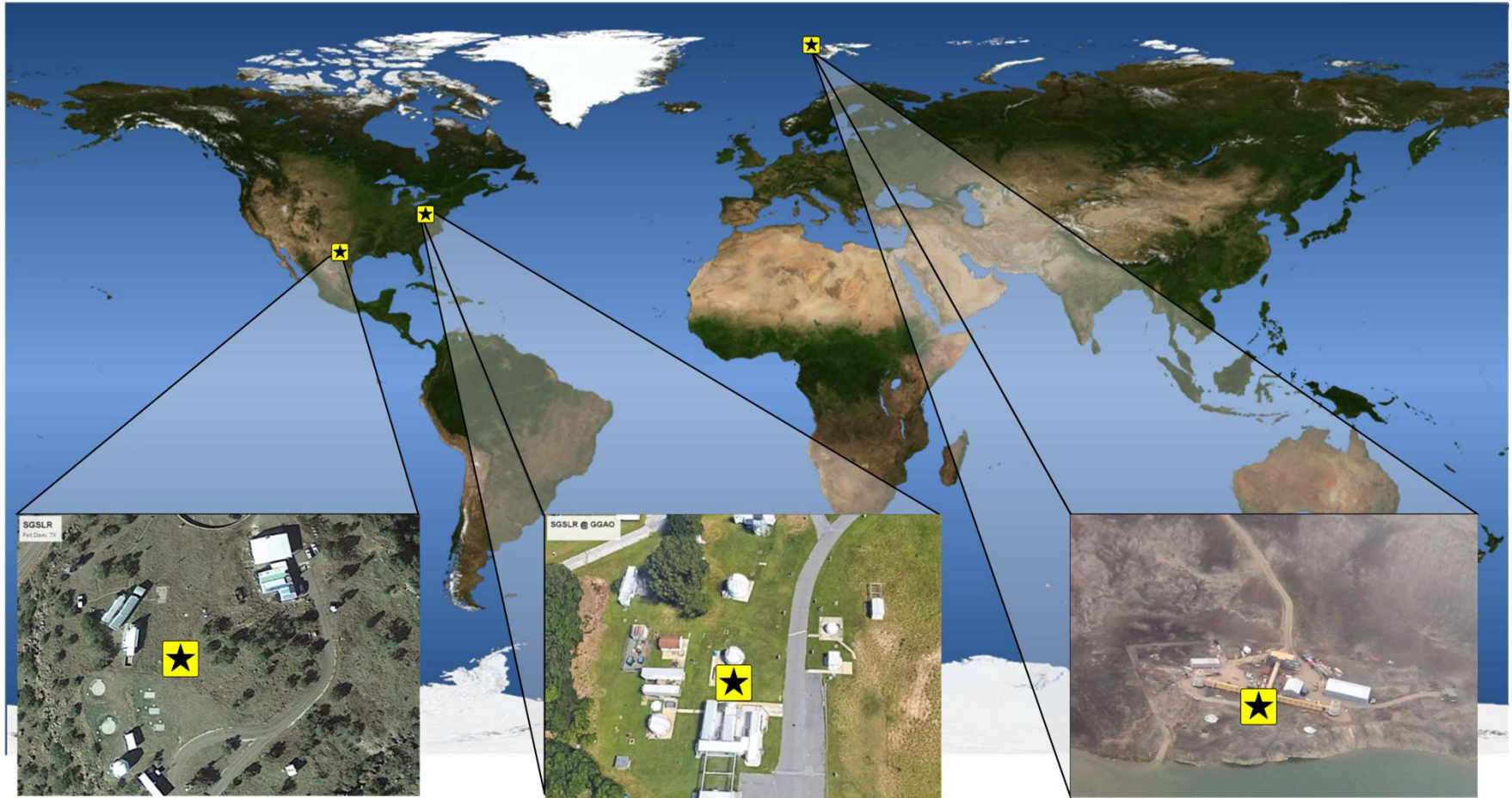

McDonald Observatory, TX
(MGO)

Greenbelt, MD
(GGAO)

Ny-Alesund, Norway
(NGO)

Drawing D-014b



Site Description: GSFC



- ◆ GGAO Site layout
 - Proximity to MOBLAS-7 for effective collocation
 - Close to GSFC: easy access for I&T and nearby SGSLR SW and HW Labs
- ◆ Facility requirements
 - Power: 72 kW
 - Internet: 500 Gb/day
- ◆ Security / Safety
 - Fenced in area surrounding entire GGAO with controlled entry
 - SGSLR facility will require smartcard access to enter
 - Fire alarms will be tied to GSFC central facilities desk
 - Emergency responders are nearby
- ◆ Local Considerations
 - Radar in use for aircraft avoidance
 - VLBI shielded from radar by a structure in addition to pointing mask
 - Pointing masks protect other ground items from getting illuminated with either laser or radar



Site Layout: GGAO

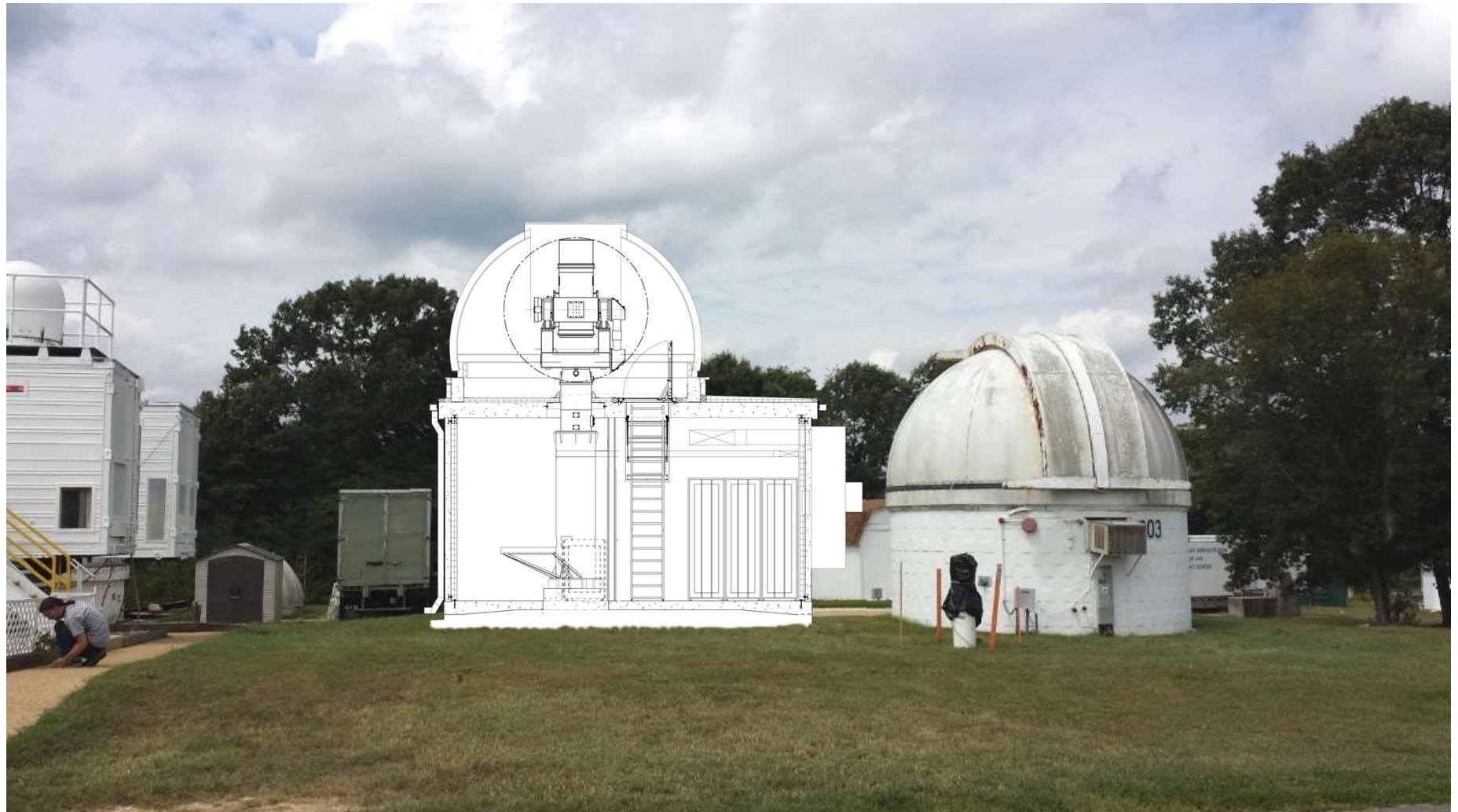



Site Layout: GGAO

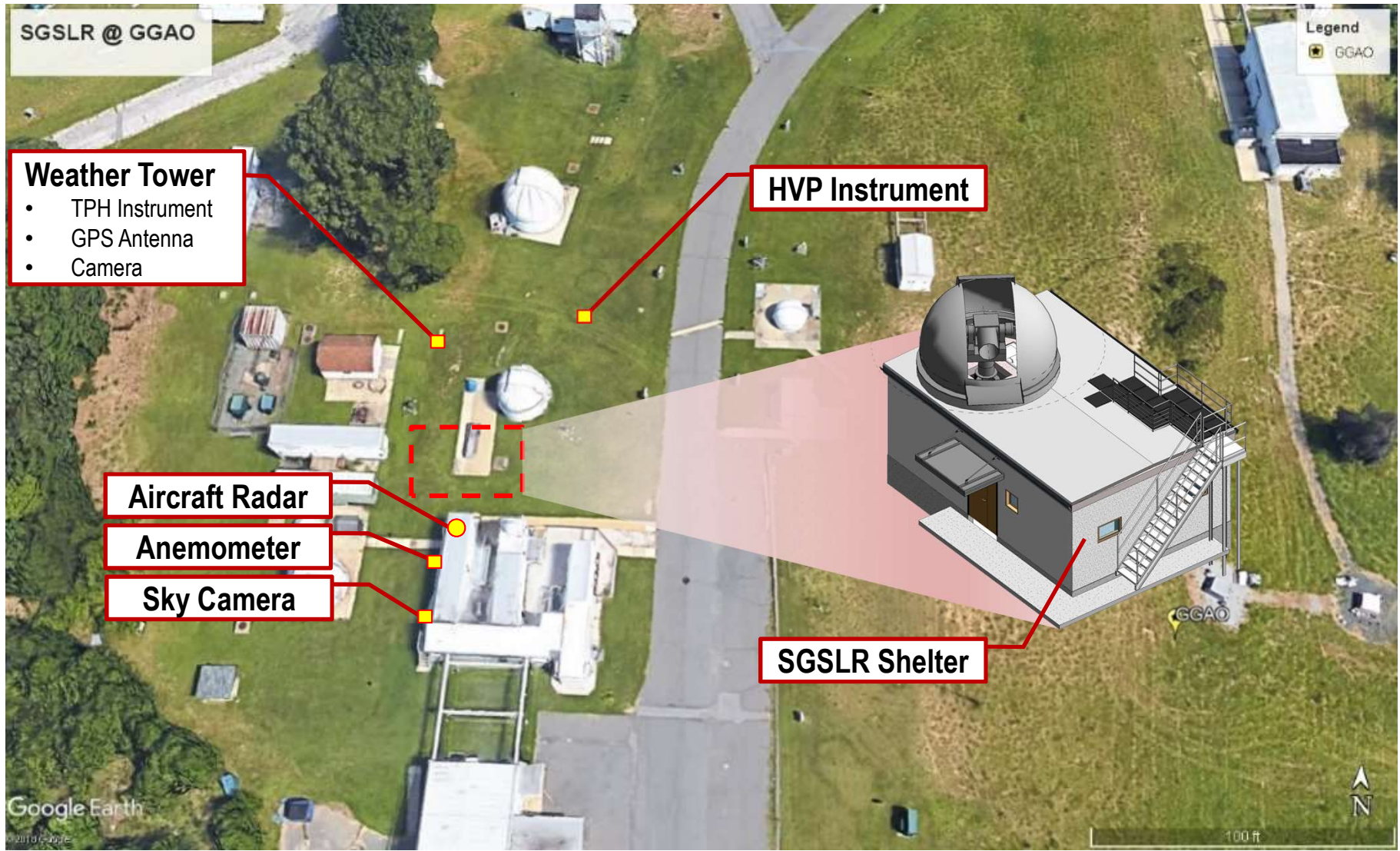



Site Description: McDonald Observatory



- ◆ MGO site layout
 - Near MLRS location
 - Within 1 km from VLBI
- ◆ Facility requirements
 - Power: 72 kW (same as GGAO)
 - Internet: 500 Gb/day (same as GGAO)
- ◆ Security / Safety
 - Very remote location – remoteness limits access
 - SGSLR facility will have keyed entry (sign in / sign out sheet will be used)
 - Emergency response will be part of existing Observatory capabilities
- ◆ Local Considerations
 - Radar used for aircraft avoidance
 - VLBI shielded by natural barrier and negative elevation from SGSLR telescope and radar
 - Pointing masks protect other ground items from getting illuminated with either laser or radar
 - Part of observatory environment with technical support available



Site Layout: McDonald Observatory

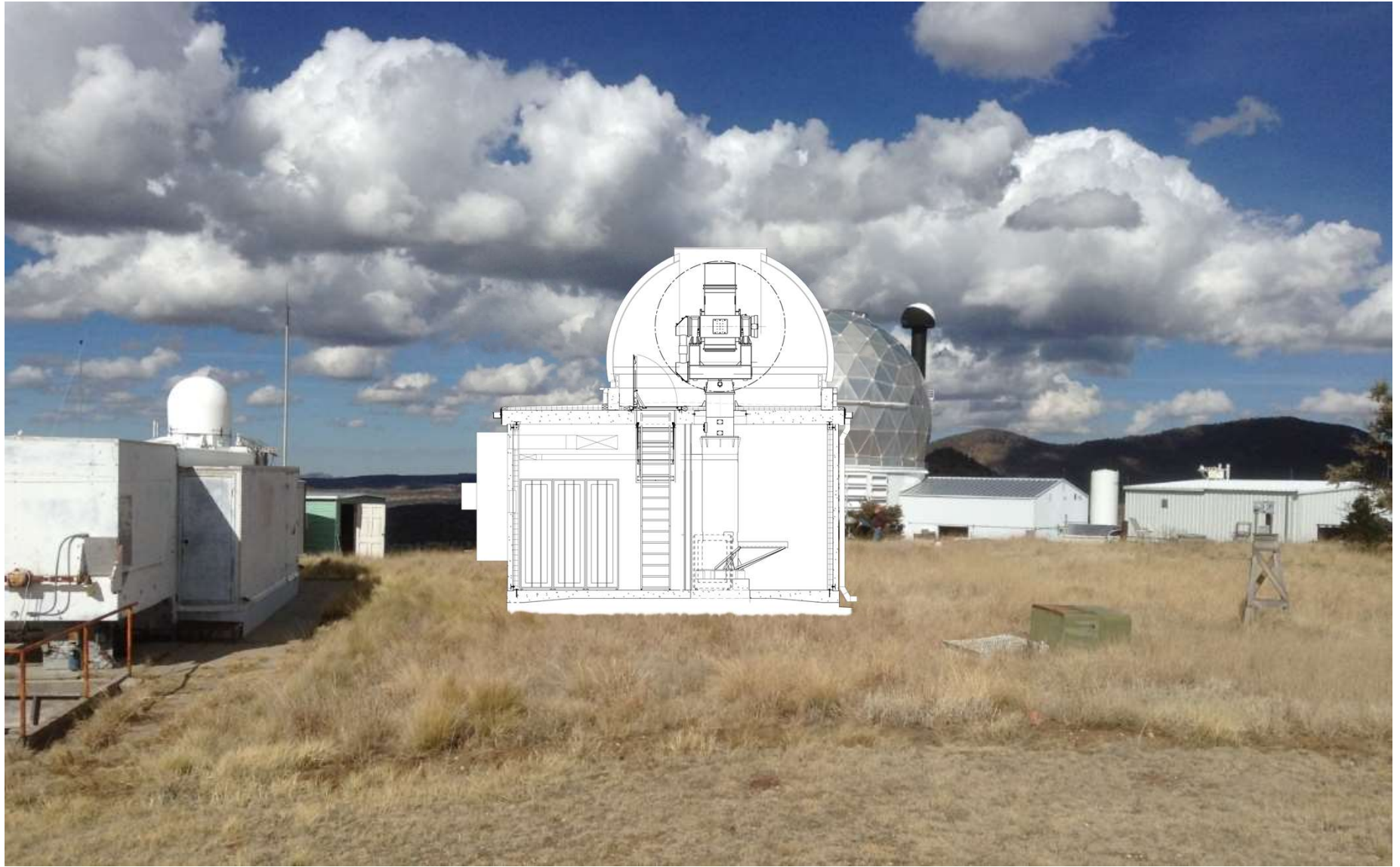



Site Layout: McDonald Observatory

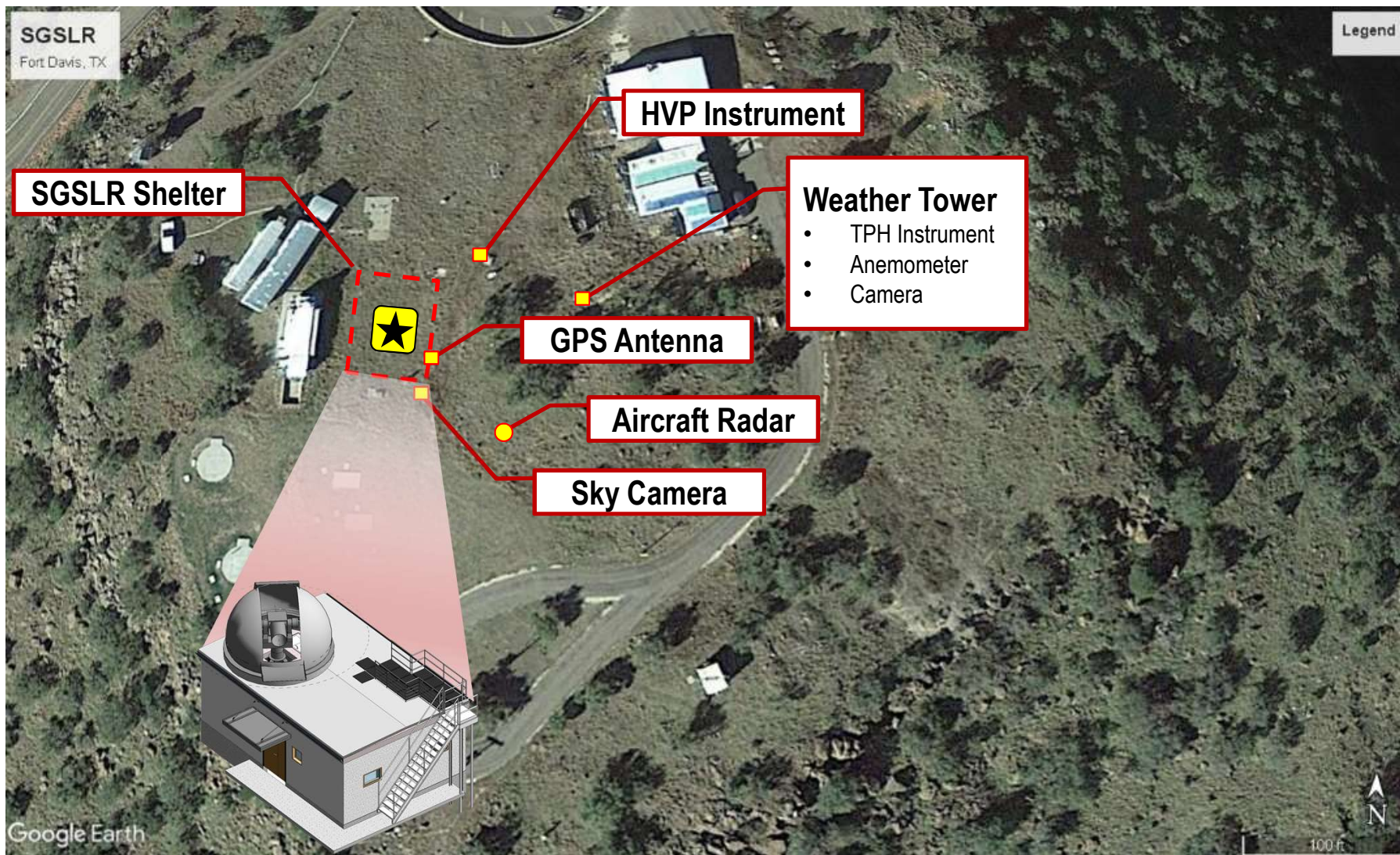



Site Description: Ny-Ålesund



- ◆ NGO site layout
 - Shelter design different from GGAO and MGO
 - Connected to VLBI and operations building through hallways
- ◆ Facility requirements
 - Power: 72 kW (same as GGAO) – SGSLR UPS will convert power as needed
 - Internet: 500 Gb/day (same as GGAO)
- ◆ Security / Safety
 - Very remote location – remoteness limits access
 - SGSLR facility will require smartcard access to enter
 - SGSLR facility has fire suppression
- ◆ Local Considerations
 - Radar not allowed
 - Pointing masks protect ground items from getting illuminated by laser
 - Local airport will have laser disable switch
 - Remote location / arctic conditions of site provides challenges for human operations



Site Layout: Ny-Ålesund

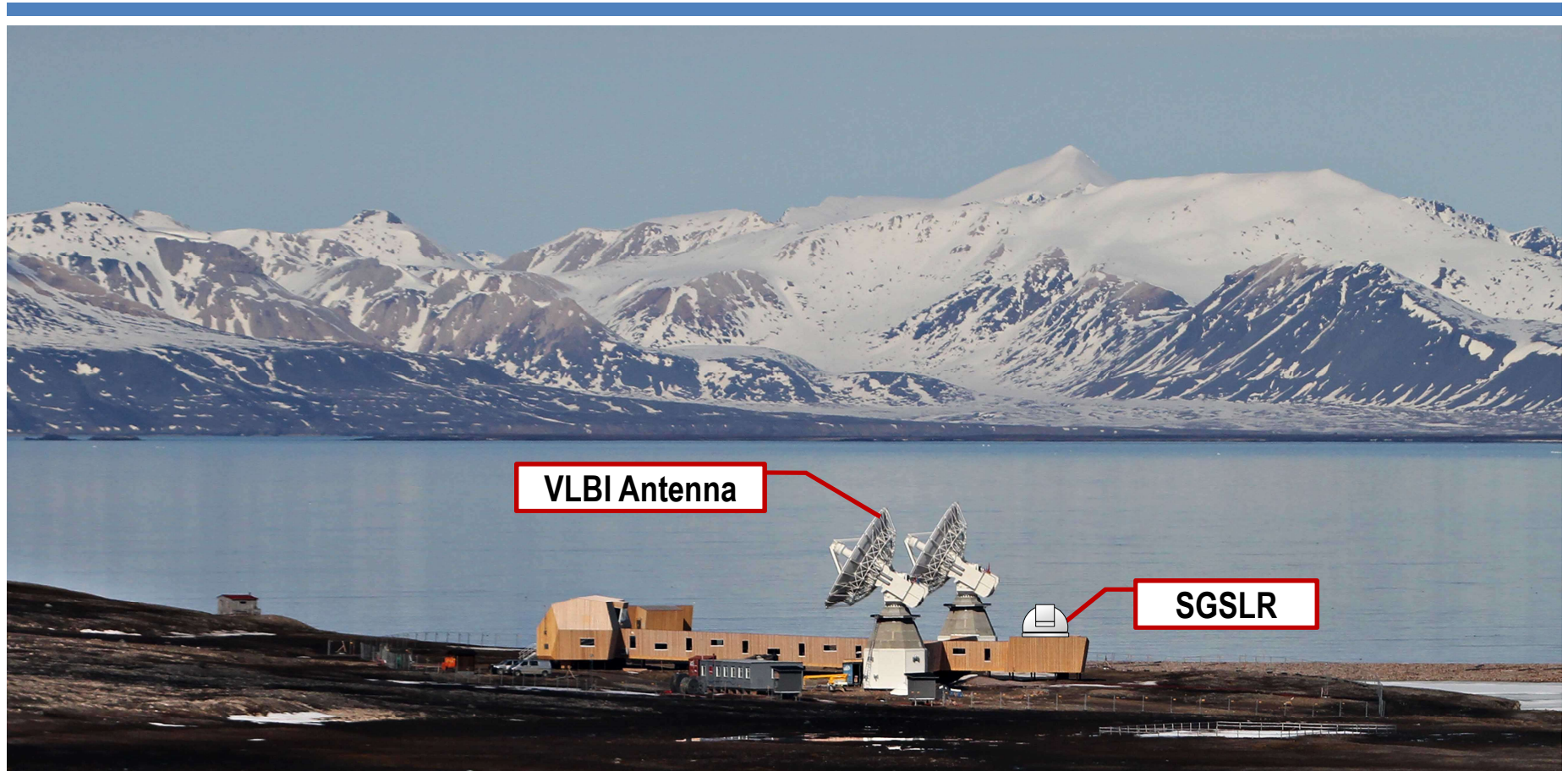

NOTES:

- Shelter already constructed; Dome not yet installed
- Unique shelter design
- Co-located with VLBI



Site Layout: Ny-Ålesund

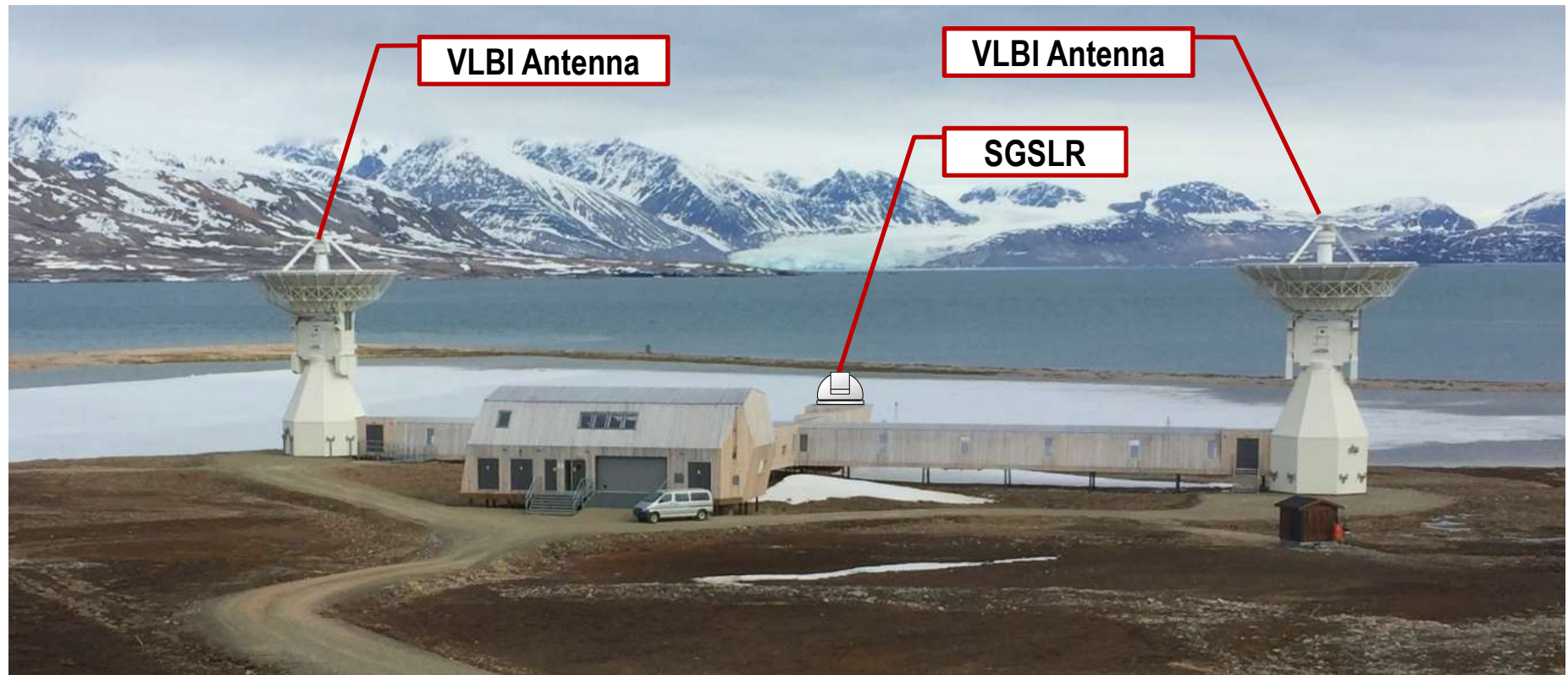

NOTES:

- Shelter already constructed; Dome not yet installed
- Unique shelter design
- Co-located with VLBI



Site Layout: Ny-Ålesund



NOTES:

- Shelter already constructed
- Unique shelter design
- Co-located with VLBI
- Arctic Location
- No radar at this site

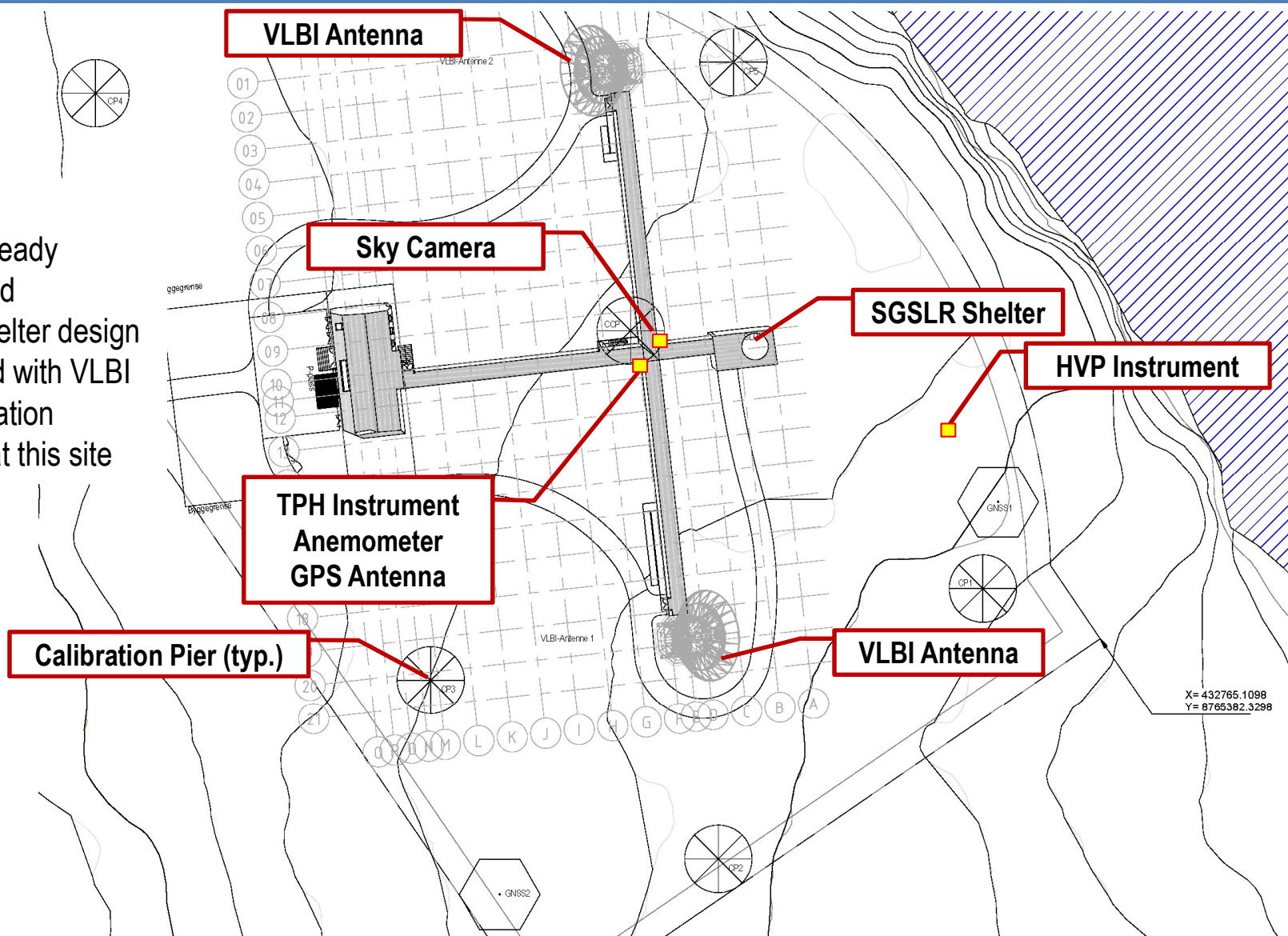



Comparison of Subsystems by Site



Subsystem	GGAO	MGO	NGO
Telescope and Gimbal	<i>Baseline Design</i>	<i>Baseline Design</i>	<i>Baseline Design</i>
Time and Frequency	<i>Baseline Design</i>	<i>Baseline Design</i>	<i>Baseline Design</i>
Optical Bench	<i>Baseline Design</i>	<i>Baseline Design</i>	<i>Baseline Design</i> Optical bench height based on NGO riser
Meteorological	<i>Baseline Design</i>	<i>Baseline Design</i>	<i>Baseline Design</i>
Laser Safety	<i>Baseline Design</i>	<i>Baseline Design</i>	<i>Baseline Design</i> Aircraft detection method, no radar allowed - NMA assessing detection method
Laser	<i>Baseline Design</i>	<i>Baseline Design</i>	<i>Baseline Design</i>
DSPR	<i>Baseline Design</i>	<i>Baseline Design</i>	<i>Baseline Design</i> NMA built shelter (smaller) Pier and Riser Height Different. UPS will convert local power.
Receiver	<i>Baseline Design</i>	<i>Baseline Design</i>	<i>Baseline Design</i>
Computer & Software	<i>Baseline Design</i>	<i>Baseline Design</i>	<i>Baseline Design</i>
Network Architecture	<i>Baseline Design</i>	<i>Baseline Design</i>	<i>Baseline Design</i>

Standardized design can be applied to most locations



Network Architecture



Site Network at Ny-Ålesund

Ny-Ålesund site network: Einar Gautun



Ny-Ålesund Site Network

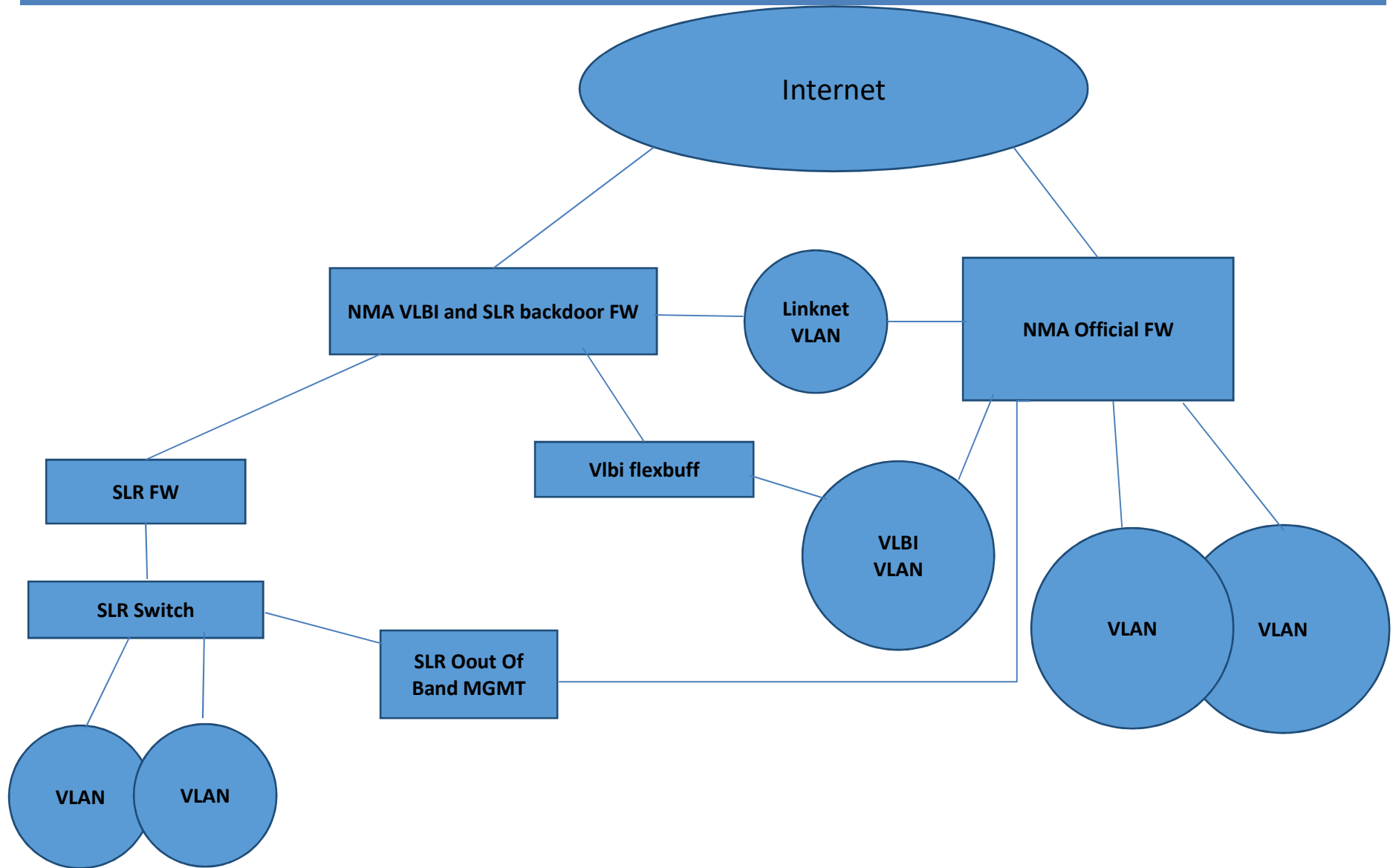



SGSLR Network at McDonald

SGSLR Design Lead: Mike Kozlowski



MGO SGSLR network

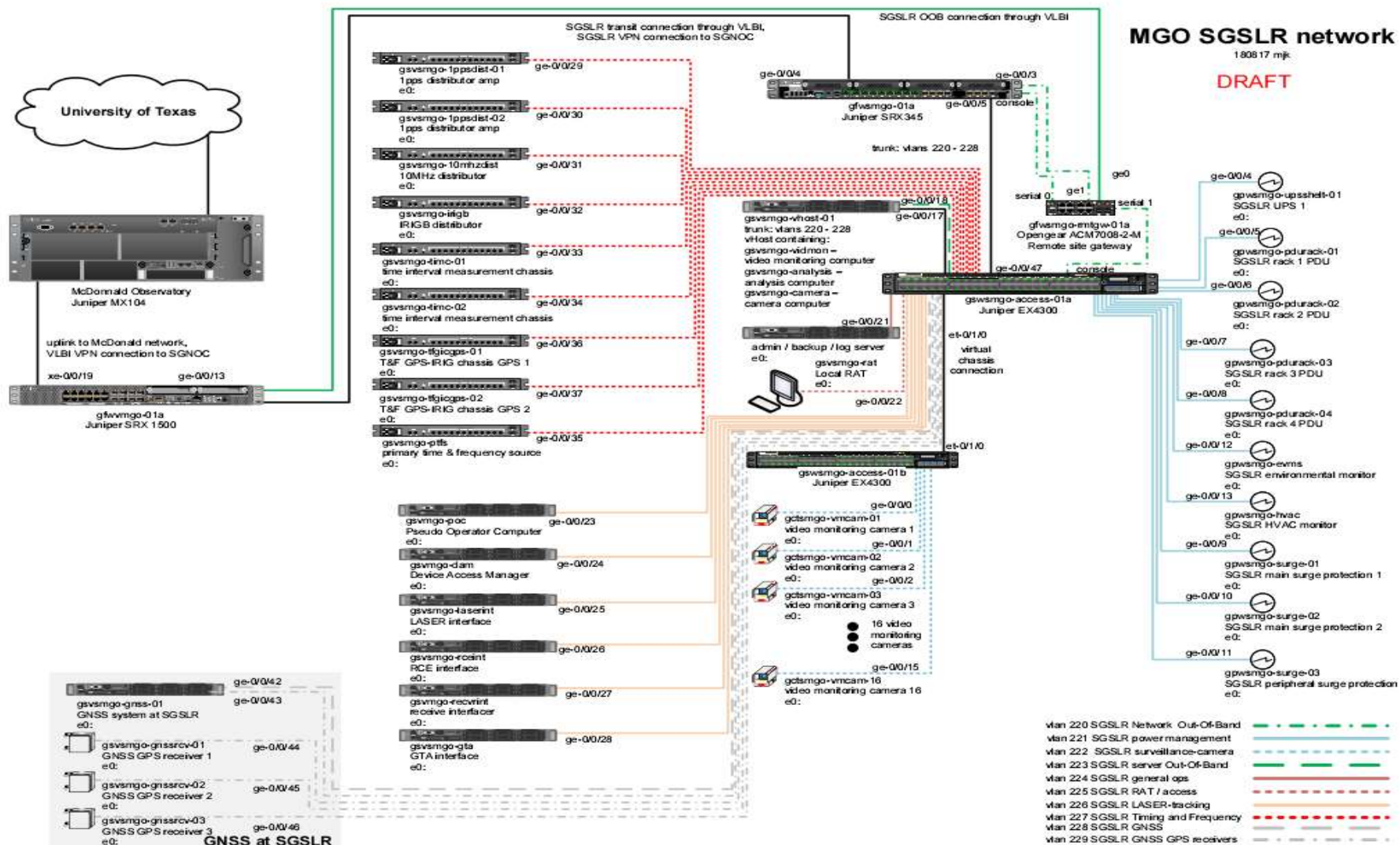



Build security into the network



- ◆ Subsystems are grouped into Virtual Local Area Networks – VLAN's.
- ◆ Each VLAN has it's own subnet to isolate traffic from the other VLAN's.
- ◆ Traffic between VLAN's is forced to route through a firewall.
- ◆ Firewalls are by design 'deny any' traffic devices, firewall rules are needed to permit a traffic to flow through a firewall.
- ◆ Firewall rules are configured to document the data flow through the network. No general permit rules are configured.



Cookie Cutter Site Implementation



- ◆ All sites are implemented using the same network topology, VLAN, IP subnet layout, and hardware.
- ◆ Eliminates confusion of each site having a different and unique layout.
- ◆ Personnel should be able to operate multiple sites due to the same layout for each site.
- ◆ Allows the use of the same components for each site, which reduces sparing and maintenance costs.
- ◆ Allows the use of standardized configurations.
- ◆ Able to accommodate special situations if needed.



IP addressing & Host Names



- ◆ Each site uses private IP addresses (RFC1918).
- ◆ Systems that require inbound or outbound access to other sites or the internet, utilize Network Address Translation (NAT) to allow traffic to be routed outside of the local site.
- ◆ Using private address space insulates the site from changes in external connectivity because changes to external IP addresses are handled by updating the NAT table and not having to readdress all the internal hosts of the network.
- ◆ Private addresses reduce the need for routable public IP addresses to only the systems that need external connectivity.
- ◆ The host name is formatted to allow personnel to determine the device type, location, and function from the host name.
- ◆ Every device has a unique host name and IP address that is assigned to it in the SGNOC IP management system which allows centralized monitoring and management.



Site Connectivity



- ◆ SGSLR has modest bandwidth requirements of less than 1 Gbps.
- ◆ At McDonald Observatory, there are limited router ports to various locations on site, McDonald management would like to assign the minimal port count to the various SGP sites.
- ◆ To accommodate this requirement, SGSLR will use the VLBI firewall to provide a 1 Gb transit connection to the McDonald network.
- ◆ 1 Gb connection also applies to GGAO and NGO.
- ◆ The VLBI firewall will have a 10 Gb connection to the McDonald Observatory network and will be the demarcation connection to the McDonald network.



Equipment Specifications



- ◆ The MGO network will utilize Juniper network equipment.
- ◆ The SGLSR firewall will be the SRX345.
 - 8 ports 10/100/1000 baseT copper, 8 ports 1Gb SFP.
 - Statefull Firewall (Maximum with 1518 Byte Packets) 5 Gbps.
 - VPN Throughput (Maximum with 1400 Byte Packets) 800 Mbps.
- ◆ The VLBI firewall is the SRX1500.
 - 12 ports 10/100/1000 baseT copper, 4 ports 1Gb SFP, 4 ports 10Gb SFP+.
 - Statefull Firewall (Maximum with 1518 Byte Packets) 9 Gbps.
 - VPN Throughput (Maximum with 1400 Byte Packets) 4 Gbps.
- ◆ The primary switches used at MGO will be the EX4300.
 - 48 ports 10/100/1000 baseT copper, 4 ports 1Gb SFP/ 10Gb SFP+
 - Packet Switching Capacities (Maximum with 64 Byte Packets) 496 Gbps
 - Layer 2/Layer 3 Throughput (Mpps) (Maximum with 64 Byte Packets) 369 Mpps (wire speed)



Virtual Private Network



- ◆ Both the SRX345 and the SRX1500 provide the capability to establish VPN's
- ◆ The permanent VPN between the SGNOG and MGO will be an IPSEC tunnel.
- ◆ The traffic transiting the tunnel will be treated as internal traffic as if both locations were connected physically.
- ◆ Users logging into the network from an external location will use an VPN client on their desktop / laptop.
- ◆ Each of the site firewalls will allow for a direct VPN, to allow local users to not have to go all the way back to GSFC.
- ◆ These VPN's will force you to the site jump box.
- ◆ The VPN client will disable split-tunneling, i.e. having a VPN connection and another connection that goes to the internet. The client will disable external connectivity that does not flow through the tunnel. The only allowed connection is the one established by the VPN client.



Safety



SGP Safety

Josh Allen, SGP Safety Lead, Code 360



Introduction



- ◆ The System Safety Program Plan (SSPP) establishes the overall System Safety Program for the Space Geodesy Project (SGP) and describes the safety approach to be followed during the design, development, fabrication, assembly, handling, transportation, installation, verification, operation, and maintenance of the NASA Space Geodesy Network (NSGN).
- ◆ The SSPP establishes the safety requirements, milestones, management responsibilities, and analysis methods for accomplishing the program safety objectives.
- ◆ Every person on the SGP project is responsible for safety. Every person is responsible for adherence to safety requirements, for the implementation of good practices and techniques and for conditions, whether existing or anticipated, that they consider hazardous.



Policy



- ◆ The activities included in the safety program are intended to assure that potential hazards to personnel or equipment are either eliminated or, as a minimum, controlled to an acceptable level.
- ◆ The SGP safety program will comply with all local, state, federal, national and international regulations regarding safety (NASA Goddard Directives Management System (GDMS) for actual documents pertaining to Laser Safety, Fall Protection, Electrical Safety, etc.:
<https://gs279gdmsias.gsfc.nasa.gov/GDMSv2/filterResults.htm>)
- ◆ The SGP Project Manager is ultimately responsible for the safety of the hardware and personnel for the SGP mission throughout the entire life of the project.
- ◆ Very Long Baseline Interferometry (VLBI) and Satellite Laser Ranging (SLR) operation managers and development leads are responsible for safety of SGP hardware and personnel at their facilities, and will cooperate with the SGP Project Manager in assuring safe operations in their facilities as well as flow down of safety requirements to their subcontractors.



Roles and Responsibilities



Project Manager (Stephen Merkowitz)

Designates personnel roles and responsibilities within the project
Ensures that safety activities are planned and that adequate resources are provided for those activities

Project Safety Manager (Joshua Allen)

Conducts a Preliminary Hazard Analysis
Documents safety plans, decisions, processes, and results
Develops and maintains a Systems Safety Program Plan (SSPP)
Participates in formal safety reviews and project milestone reviews.



Training



- ◆ All personnel shall be trained to operate and function safely, utilize personal protective equipment (PPE), and use tools, equipment, and chemicals in accordance with labeled precautions and safe operation processes.
- ◆ In the unlikely event of an accident or exposure, personnel will follow the notification process outlined in the mishap investigation and reporting section of the SSPP and documents the event.
- ◆ Root cause investigation results in corrective action, training, and additional protection, if available.
- ◆ Supervisors and managers are responsible for ensuring that all personnel are trained and that measures to provide safety are functional and available. The managers are responsible for flowing down all safety requirements to team members working on site and training will be provided as appropriate.



SGSLR Safety

Howard Donovan, SGSLR Deputy Lead



SGSLR Safety - Agenda



- ◆ Safety, Health, and Environmental (SHE) Process
- ◆ Key Requirements
- ◆ Key SHE Aspects and Risks
- ◆ Mitigations Implemented to Control SHE Risks



SGSLR Safety



- ◆ Safety Health, and Environmental (SHE) Process
 - SHE aspects and risks identification is included in the full lifecycle of the project.
 - Starts with preliminary hazard assessment to identify aspects and risk. These aspects and risks are evaluated and project requirements are developed.
 - Hazard assessment includes personnel safety and system safety considerations during design, installation, operation, maintenance, and service.
 - Hazard assessment identifies initial risk without controls
 - Controls are identified and later implemented to reduce risk to an acceptable level (final risk level is capture on your final hazard assessment)
 - Controls are established based on the hierarchy of controls
 - Elimination, Substitution, Engineering, Administrative, and PPE
 - These controls are incorporated as part of the design and the hazard assessment is living tool that is updated at system engineering gates (e.g., PDR, CDR, ORR)



SGSLR Safety – Key Requirements



- ◆ Key Requirements/Standards Used Include:
 - OSHA Standards
 - 29 CFR 1910 General Industry and 1926 Construction
 - NASA Procedural Requirements (NPR)
 - NPR 8715.3, NASA General Safety Program Requirements
 - NASA-STD-8719.11, Safety Standard for Fire Protection
 - NASA-STD-8719.9, Standard for Lifting Devices and Equipment
 - Goddard Procedural Requirement (GPR)
 - GPR 1700.5, Control of Hazardous Energy
 - GPR 1700.6, Confined Space Program Requirements
 - GPR 1700.7, Electrical Safety
 - GPR 1860.3, Radio Frequency Radiation Protection
 - GPR 8715.8, Fall Protection Requirements for GSFC



SGSLR Safety – Key Requirements



- ◆ Key Laser Requirements/Standards Used Include:
 - NASA Procedural Requirements (NPR)
 - NPR 8715.3, NASA General Safety Program Requirements
 - NPR 1800.1, NASA Occupational Health Program Procedures
 - Goddard Procedural Requirement (GPR)
 - GPR 1860.2, Laser Radiation Protection
 - GPR 1860.3, Radio Frequency Radiation Protection
 - Federal Aviation Administration (FAA)
 - AC70-1, Outdoor Laser Operations
 - American National Standards Institution (ANSI)
 - Z136.1 – 2014, American National Standard for Safe Use of Lasers
 - Z136.6 – 2015, American National Standard for Safe Use of Lasers Outdoors
 - Society of Aerospace Engineers (SAE)
 - AS6029A, Performance Criteria for Laser Control Measures Used for Aviation Safety
 - ARP5293, Safety Considerations for Lasers
 - ARP5572, Control Measures for Laser Safety



SGSLR Safety – GGAO Identified Risks



◆ Key Risks to Control in Design

- Laser Safety Indoor & Outdoor
- Fall Protection
- Hazardous Energy Control
- RF Transmitter
- Fire Protection
- Lightning Protection
- Single Operator/Remote Location

◆ Additional Risks

- Heavy objects
- Facility security
- System build
- Job Hazard Assessment/Analysis
- Weather monitoring/notification
- Chemical
- Ladder



SGSLR Safety – Laser Safety Indoor & Outdoor



- ◆ Engineering Controls
- ◆ Signage
- ◆ Laser Safety Plan
- ◆ Procedures
- ◆ Laser Safety Officer and Laser Custodian
- ◆ PPE
- ◆ LOTO

Laser Hazard Reduction System (Radar)



Operator Control



Beam Block/Attenuator

Control Chassis

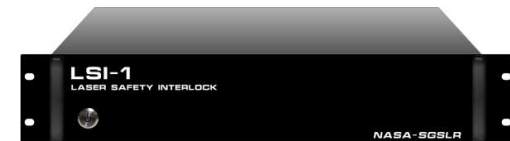



SGSLR Safety – Fall Protection



- ◆ Railings on stairs to roof
- ◆ Railings on roof around walkways
- ◆ Procedures

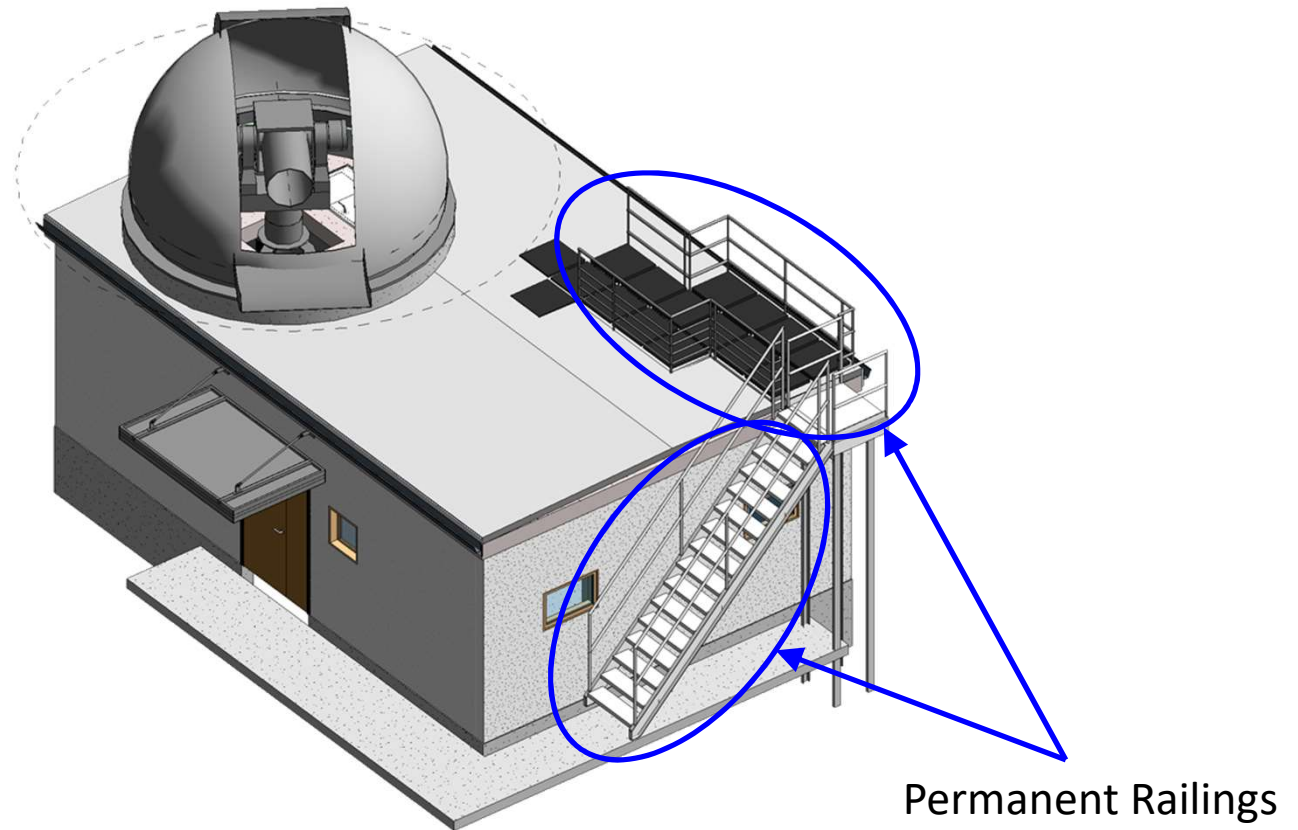

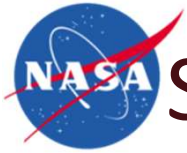

SGSLR Safety - Hazardous Energy Control



- ◆ Equipment with hazardous energy designed with isolation in mind
 - UPS, GTA, Dome, Radar, Laser, MCP
- ◆ Hatch/Door interlocks
- ◆ Emergency Stop (for emergencies only)
- ◆ Procedures - Lockout/Tagout
- ◆ Training



SGSLR Safety – Radio Frequency



- ◆ Engineering Controls
- ◆ Signage
- ◆ Procedures
- ◆ Code 360 Coordination
 - RF Hazard analysis
 - 23-28RF
 - Experience with NGSLR and Heritage SLR Network





SGSLR Safety – Fire Protection



- ◆ SGSLR at GGAO will be tied into GSFC Fire Detection System
- ◆ Fire detectors designed in accordance with NASA-STD-8719.11 and NFPA 72
- ◆ Fire extinguishers provided
- ◆ Procedures



SGSLR Safety – Lightning Protection



- ◆ Counterpoise ground field
- ◆ Air terminals
- ◆ Main Power UPS
- ◆ Surge/spike arrestor system
- ◆ Fiber optic external data interfaces

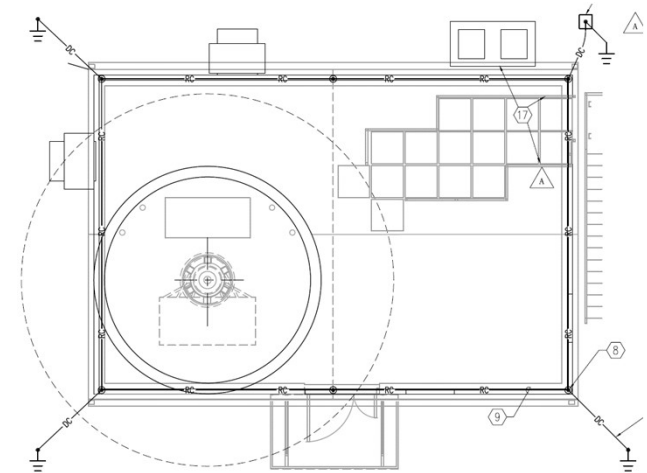
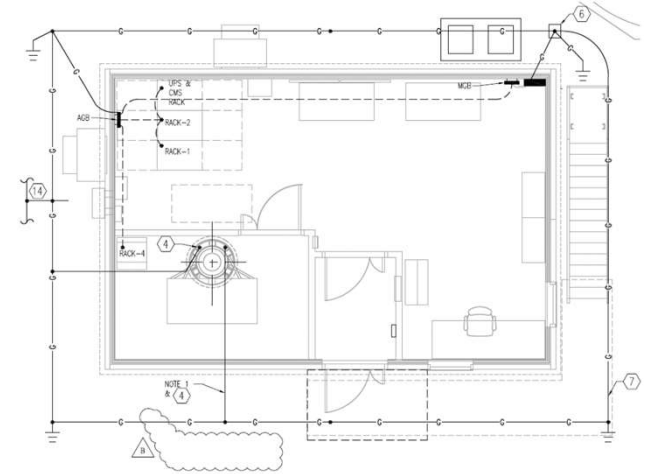



SGSLR Safety – Single Operator/Remote Location



◆ GSFC/GGAO

- Cellphone
- GSFC Security
- Procedures
 - Single operator for SLR operations, administrative activities, and other low hazard activities
 - No high hazard work allowed such as work at heights or energized electrical work
 - Procedures will be established for single operator work



SGSLR Safety – Installation/Ops/Maintenance



◆ Installation Safety

- GSFC Code 220 managed contractor for shelter build will be completing installation and responsible for safety in accordance with their normal procedures
- KBRwyle responsible for overseeing GTA & Dome installations
 - Contractor safety plan, lift plan, and verify training and qualifications (e.g., rigger certifications)
- KBRwyle will perform installation of equipment – governed by safety plan and JHA will be developed

◆ Operational and Maintenance Safety Requirements

- Considerations included in hazard assessment and the hazard controlled
- Procedures will be developed prior to ORR (e.g., emergency procedures, equipment specific lockout/tagout procedures, laser alignment procedures, etc.)
- Laser safety training requirements
- FAA coordination



SGSLR Safety – System Operation Coordination



◆ Laser Operations

- NASA HQ
 - Laser Safety Review Board
- GSFC Code 360
 - 23-6L, Laser Radiation Source Use Approval
 - 23-28L, Laser Radiation Source Questionnaire
 - 23-35LU, Laser Radiation Source Personnel approval
 - Non-Ionizing Radiation Safety Committee (NIRSC) Training Certification
- FAA
 - AC70-1, Outdoor Laser Operations
 - FAA form 7140-1, Notice of Proposed Outdoor Laser Operations

◆ Radar Operations

- Code 360 RF Coordination
 - 23-28RF, RF/Microwave Source Questionnaire
- GSFC Spectrum Management Office
 - National Telecommunications and Information Administration
 - Radio Frequency Authorization



SGSLR Laser Safety

(with focus on GGAO)

Howard Donovan, SGSLR Deputy Lead



SGSLR Laser Safety



- ◆ A comprehensive hazard analysis has been performed
 - Indoor hazard analysis
 - Outdoor hazard analysis
- ◆ Identified hazards associated with the operation, test, and maintenance involving the use of the laser



SGSLR Laser Safety - Indoor



◆ Indoor Laser Hazards

- Identify laser parameters and determine the following according to the ANSI Z136.1, American Standard for Safe Laser Use
 - Maximum Permissible Energy (MPE)
 - Nominal Ocular Hazard Distance (NOHD)
- Review the physical layout of the laser room, optical bench and operations area
- Identify potential laser hazards and hazard zones, determine energy densities
- Review optical alignment procedures
- Identify associated laser hazards



SGSLR Laser Safety – Laser Parameters



◆ Photonics Industries RGL-532-2.5 (Out of the laser)

- Energy 2.5 mJ
- Repetition Rate Max 2,000 Hz Max
- Power 5.0 W
- Divergence < 1 mrad
~ 206 arcsec
- Beam Diameter 1.7 mm
- Pulse Width 50 ps
- Spatial Mode TEM₀₀



SGSLR Laser Safety – Indoor



◆ MPE	2.000E-7 J/cm ²
◆ NOHD Indoor Hazard Ranges	
— 2.5 mJ energy (Operational)	1.26 kilometers 0.78 statute miles
• PPE OD for Eyesafe*	4.51
— 20 μJ energy (Alignment)	112.8 meters 370 feet
• OD for Eyesafe*	2.51

*NOHD is limited inside laser enclosure and laser room



SGSLR Laser Safety - Indoor



◆ Hazard Mitigation

- Enclosed laser
- Separate Room for laser
- Laser Interlock
 - Door interlock, beam blocks, etc.
- Signage
- Video Monitoring
- Procedures
- Indirect Beam Path to entrance/exit door
- PPE (laser eyewear selected based on ANSI Z136.1)
- Training/Periodic Training
- Certification required for various duties
 - SLR Operations, Laser User, Optical Alignments

 WARNING	
	Class 4 Laser Controlled Area Avoid eye or skin exposure to direct or scattered radiation. <i>Do not enter when light is illuminated.</i> Laser eye protection required: PULSED – VISIBLE Nd:YAG 532 nm / 1.0 mJ / 2 kHz / >4.7 OD Nd:YAG 532 nm / 20 μJ / 2 kHz / >3.0 OD
Photonics Industries Laser MODEL RGL-532-2.5	Laser Safety Officer: Howard Donovan (301) 805-3985



SGSLR Laser Interlock Sensor/Hardware Location

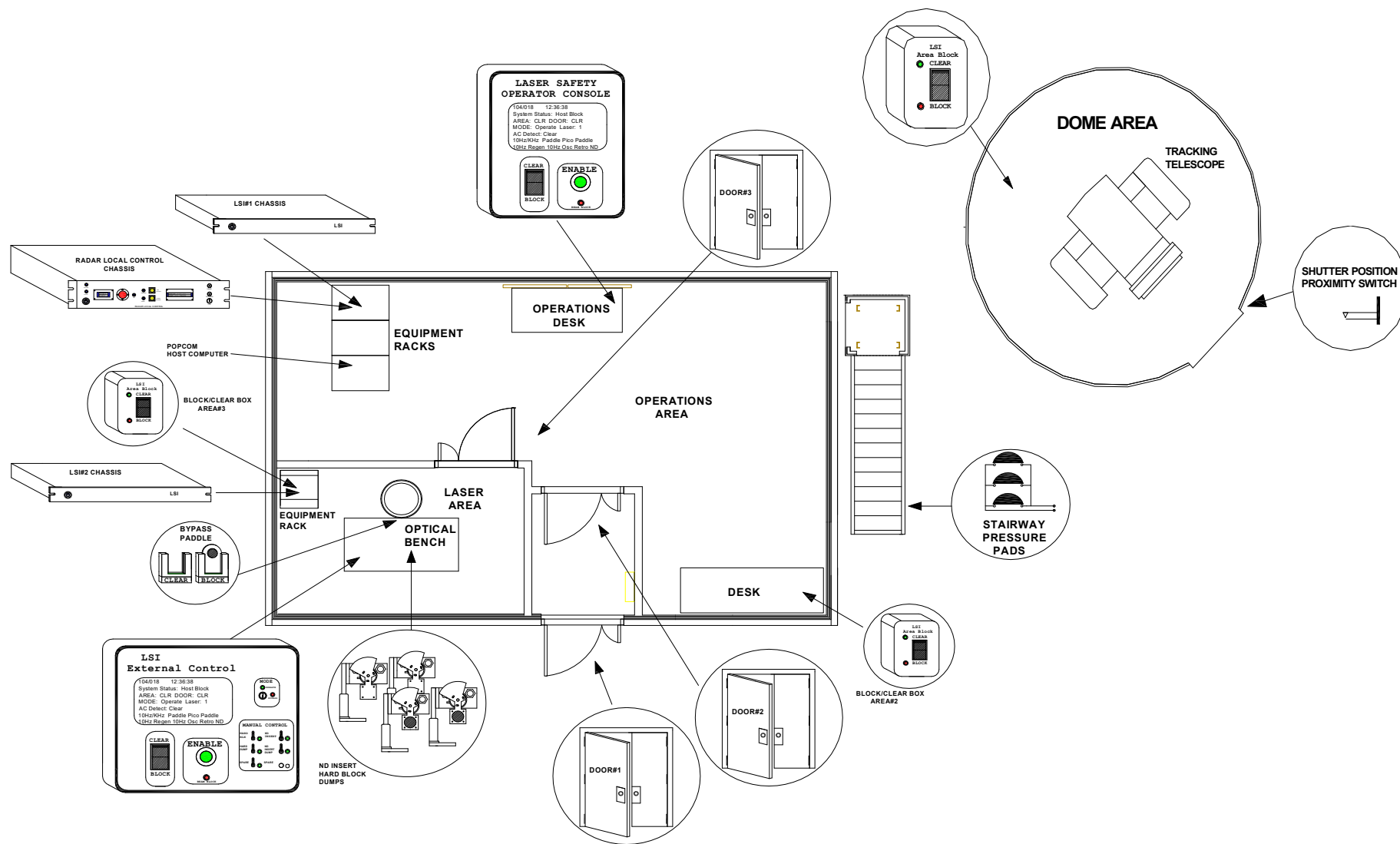



SGSLR Laser Safety - Outdoor



◆ Outdoor Laser Hazards

- Perform airspace analysis
 - Determine NOHD, Sensitive, Critical, and Laser Free hazard ranges
 - Identify airports within the NOHD, Sensitive, Critical, and Laser Free hazard ranges
 - Identify airport Sensitive, Critical, and Laser Free zones and if the transmitted laser energy will penetrate the zones
 - Determine types of aircraft, altitudes, and speeds that are expected to be in the affected airspace
 - Identify annual airport operations
 - Identify nearby operations that use the affected airspace volume and if they will be affected by satellite laser ranging activities
- System and operation
 - Perform horizon map noting activities, buildings, etc. that may be affected by laser operations
 - Ground ranging
 - Determine effects of ground ranging on local operations



SGSLR Laser Safety – System Parameters



◆ Laser Energy Parameters Out of the Telescope

- Transmit Optics Efficiency 81.9%
- Energy (Operational)
 - Operational 2.50 mJ => 2.05 mJ
 - Alignment 20 μ J => 16 μ J
- Repetition Rate Max 2,000 Hz
- Power 4.1 W
- Divergence 29 to 136 μ rad
6 to 28 arcsec
- Beam Diameter 88 mm
- Pulse Width 50 ps
- Spatial Mode TEM₀₀



SGSLR Laser Safety – Hazard Ranges



- ◆ MPE 2.000E-7 J/cm²
- ◆ NOHD Outdoors
 - 2.05 mJ energy (Operational)
 - 6 arcsec divergence 39.1 kilometers
24.3 statute miles
 - OD for Eyesafe 2.23
 - 16 μJ energy (Alignment) 1.8 kilometers
1.6 statute miles
 - OD for Eyesafe 1.13



SGSLR Laser Safety – Hazard Ranges



◆ ANSI Z136.6 requirements

- Laser-Free 50 nW/cm²
- Critical 5 μW/cm²
- Sensitive 100 μW/cm²

◆ Exposure Distances @ 6 arcsec divergence (worst case)

- Laser-Free 3,508 kilometers
2,180 statute miles
- Critical 348 kilometers
216 statute miles
- Sensitive 76 kilometers
47 statute miles



SGSLR Laser Safety – ANSI Flight Zones



Normal Flight Zone
 2.6 mW/cm^2

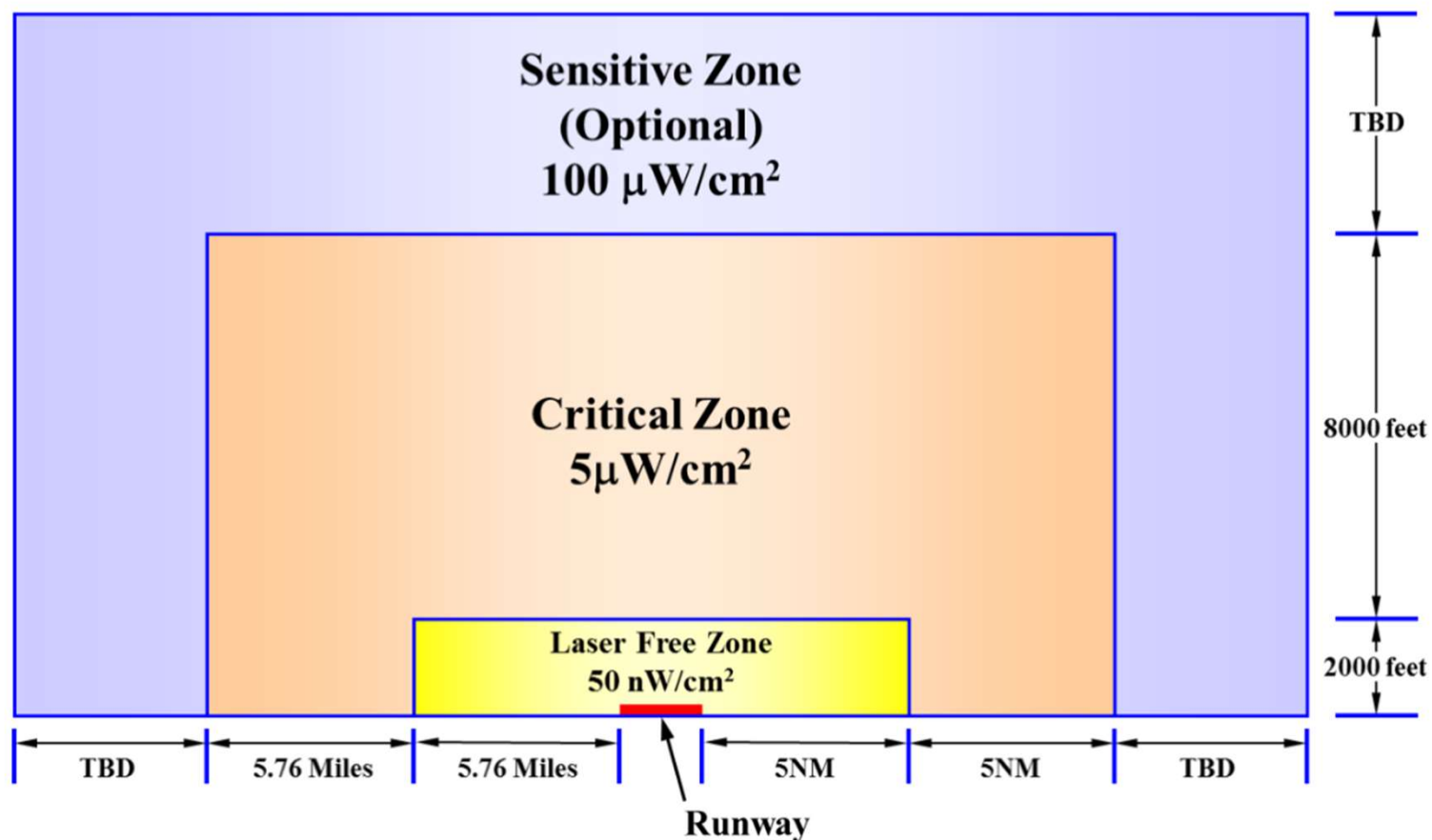



SGSLR Laser Safety – ANSI Hazard Zones

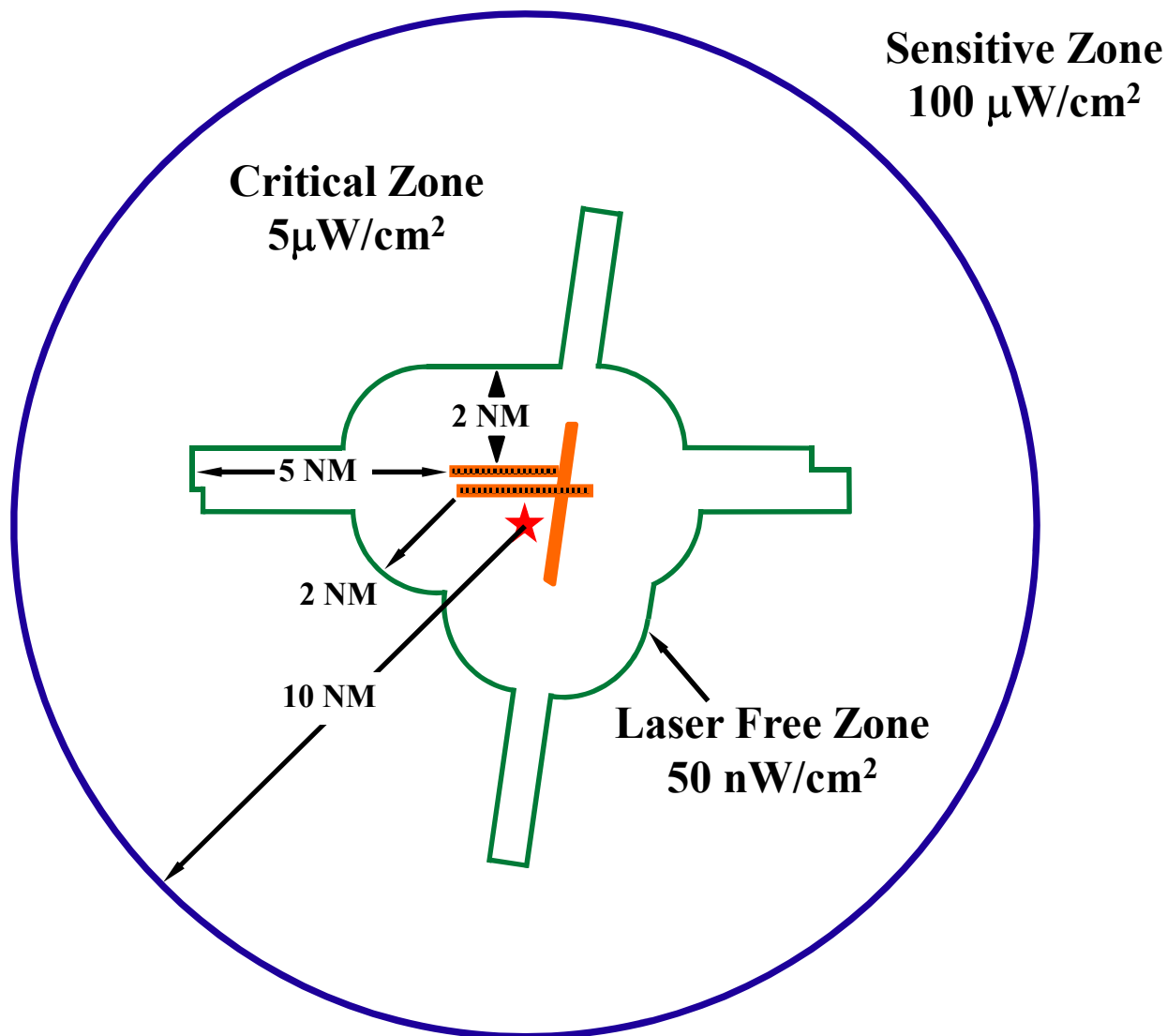



SGSLR Laser Safety - GGAO

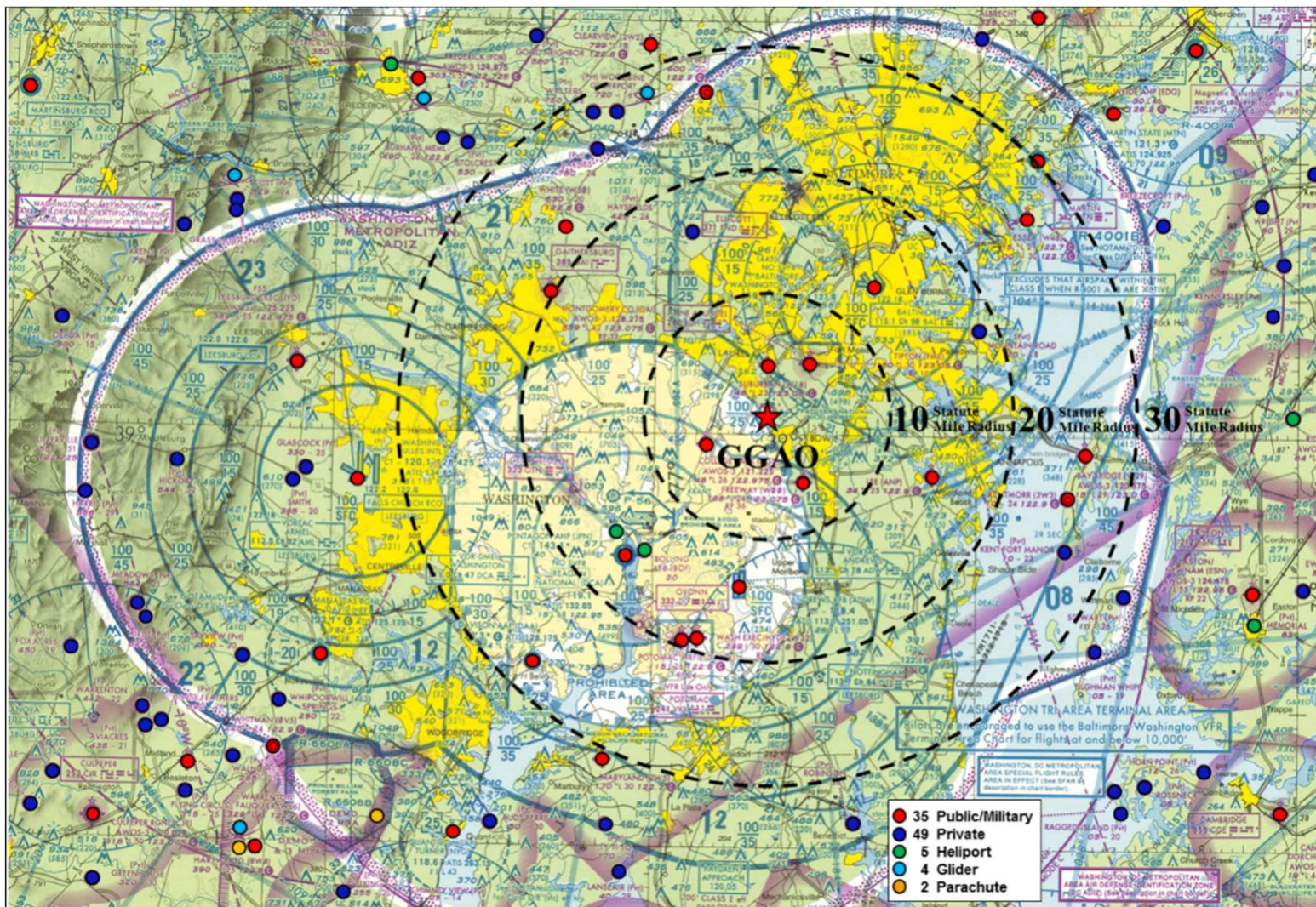

Airports in the Goddard Space Flight Center GGAO Vicinity



SGSLR Laser Safety - GGAO

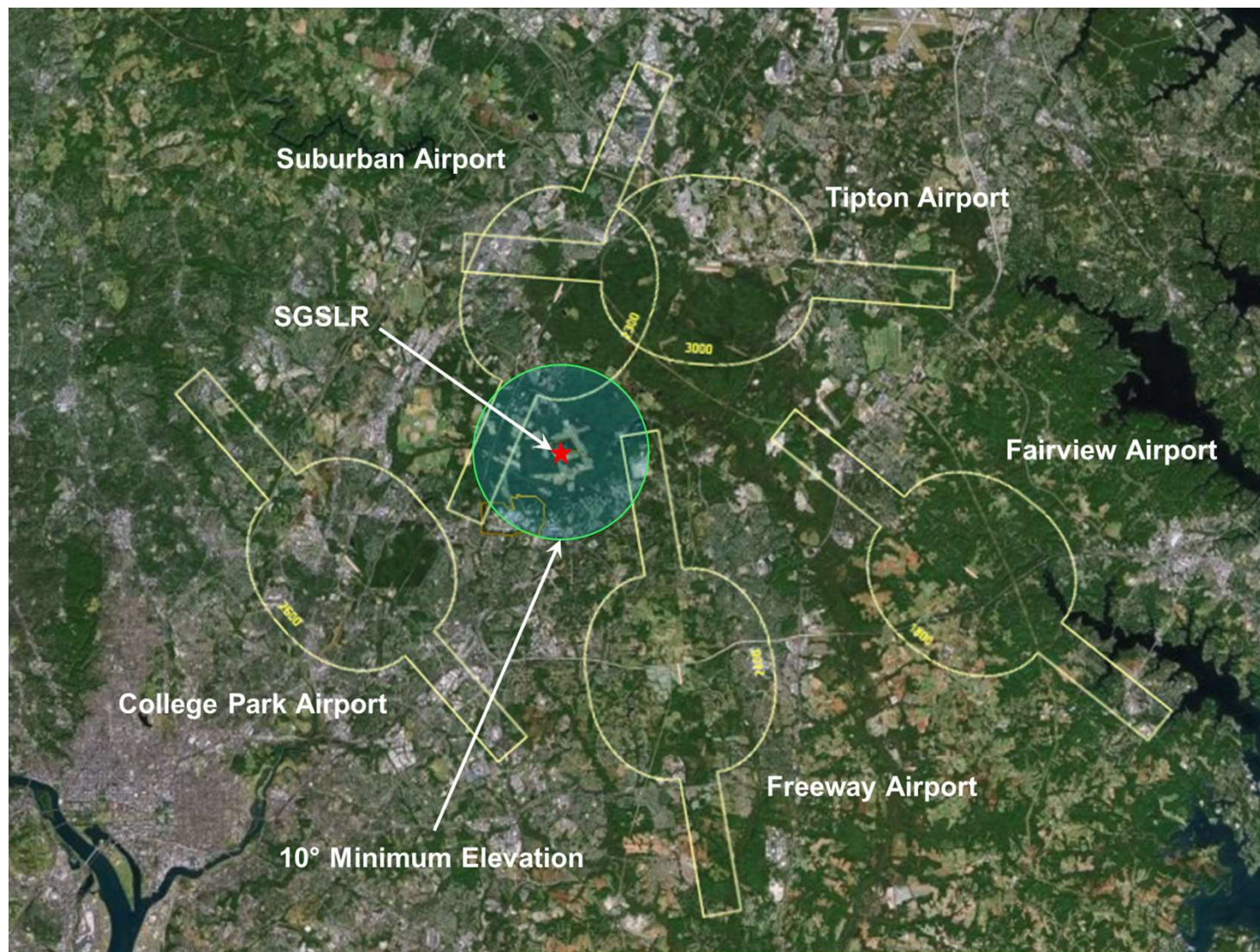

SGSLR @ GGAO Laser-Free Hazard Zones



SGSLR Laser Safety - GGAO



	Airport ID	GGAO Vicinity Airports	Airport Location	Annual Air Operations	Horizontal Range From SGSLR to Center of Airport Statute Miles	Altitude above MSL of Airport Feet	SGSLR Penetration of Laser Free Zone	SGSLR Penetration of Critical Zone	Runway Length Feet
1	W18	Suburban Airport	Laurel, MD	20,440	3.9	148	X	X	2,300
2	CGS	College Park Airport	College Park, MD	2,912	5.8	48		X	2,600
3	FME	Tipton Airport	Fort Meade/Anne Arundel Co., MD	49,275	5.8	150		X	3,000
4	W00	Freeway Airport	Mitchelville, MD	11,315	6.2	168	X	X	2,400
5	3MD4	Fairview Aiport	Annapolis, MD	N/A	10.5	150		X	1,800
6	BWI	Baltimore-Washington International Airport	Linthicum, MD	277,400	13.7	146		X	10,500
7	ADW	Andrews AFB	Camp Springs, MD	210,000	14.6	280		X	9,700
8	ANP	Lee Airport	Annapolis, MD	31,755	14.9	30		X	2,500
9	DCA	Ronald Reagan Washington National Airport	Washington DC	275,210	16.2	15		X	6,800
10	MD24	Hayesfileds Aiport	Clarksville, MD	N/A	16.3	420		X	2,400
11	MD43	Mountain Road Airport	Lakeshore, MD	N/A	19.0	70		X	1,800
12	W32	Washington Executive/Hyde Field Airport	Clinton, MD	8,760	19.6	249		X	3,000
13	VKX	Potomac Airfield Airport	Friendly, MD	12,045	20.0	115		X	2,600
14	GAI	Montgomery Co. Airpark	Gaithersburg, MD	104,755	20.8	539		X	4,200
15	MD22	Deale Airport	Deale, MD	N/A	21.6	789		X	2,000
16	W50	Davis (White) Airport	Laytonsville, MD	5,096	23.2	630			2,000

Airspace affected by SGSLR Operations at Minimum Tracking Elevation of 10°



SGSLR Laser Safety - Outdoor



◆ Hazard Mitigation

- Laser Hazard Reduction System and Laser Interlock
 - Radar aircraft detection
- Laser Transmitter Access control
 - Restricted Stairway with notice
 - Pressure Pad interlocks
- Horizon masks
- Signage
- Video Monitoring
- Training/Certification





SGSLR Laser Safety - Summary



◆ Safety Controls

- Laser Hazard Reduction System and Laser Interlock
- Integrated system safety features
 - Area Safety - Doorway Sensors/Stairway Pressure plates
 - Keyed Access to Building and Laser
 - Beam containment barriers
 - Laser Safety Chassis with automated beam block and laser fire (trigger) inhibit signal
- Laser hazard warnings, labels, and control measures
 - Warning signs and labels
 - Video monitoring system
 - Procedures and beam blocks
- Automated emergency notification system
- Safety requirements and procedures
 - General Safety Requirements (SGSLR Safety Handbook)
 - Operations Procedures (SGSLR Operations Manual)
 - System Maintenance Procedures (SGSLR Operations Manual)
 - Laser Alignment Procedures (SGSLR Alignment Manual)
 - Emergency Procedures (SGSLR Safety Handbook)



SGSLR Laser Safety - Summary



◆ Certification and Training

- Training and Certification Requirements for all users of the system
 - Certified Operators
 - Laser User Certification
 - Optical Alignment Certification
 - Laser Safety System Maintenance
- All users must follow the requirements and procedures listed in system manuals

◆ PPE/Safety Equipment (Laser safety goggles, etc.)

◆ Safety Verification

- Routine Safety Inspection
- Periodic testing
- Communication of system health and failures



SGSLR Safety and Laser Safety



- ◆ Implementation of SGSLR Safety and Laser Safety
 - Host organization responsible for adapting SGSLR plans to meet their specific location and institutional requirements
 - Site procedures
 - Unique HW requirements – aircraft detection method, etc.

McDonald Geodetic Observatory (MGO)

Ny-Ålesund Geodetic Observatory (NGO)

Host Organization is responsible for implementing SGSLR Safety and Laser Safety



Safety at MGO

Burke Fort (University of Texas)



University of Texas/McDonald Observatory MLRS/MGO Health and Safety



- ◆ UT Austin Environmental Health and Safety
 - <https://ehs.utexas.edu>
- ◆ UT Austin Fire Prevention Services
 - <https://fireprevention.utexas.edu/>
- ◆ McDonald Observatory Health and Safety
 - MOU between McDonald /MGO and UT-EHS includes provisions regarding safety procedures and expectations
- ◆ MLRS Health and Safety:
 - Laser Health and Safety Plan (McDonald Laser Ranging Operations)



UT/McD Safety Management (1)



◆ Responsible persons - UT/McD Safety

- Andrea McNair, Assistant Director of UT Campus and Occupational Safety (Austin)
- Craig Nance, Observatory Superintendent (McD)
- Steve Bramlett, Safety Officer and Fire Marshall (McD)
- Daniel Stine, Senior Occupational Safety Specialist (Austin)
- DeWayne Holcomb, UT Laser Safety Manager (Austin)

◆ Responsible person – MGO/MLRS Safety

- Jerry Wiant, MGO/MLRS Supervisor (McD)

◆ Responsible persons – Contractually-bound Contractors

- UT Project Management and Construction Services (Austin)
- NASA



UT/McD Safety Management (2)



◆ Medical Emergencies

- McD community consists of ~100 individuals, trained EMTs and paramedics
- All staff required to have radios; many phones throughout McD
- In emergencies, protocols are in place to provide the required help within minutes
- As needed: More professional response from the surrounding towns and cities (i.e., Fort Davis, Marfa, Alpine); as well as Texas A&M Forest Service, if needed (rarely)

◆ Fire

- Regular brush/fuel clearing
- Fire alarms on Simplex “automatic call-out” system with list of contacts, ensuring rapid response by multiple personnel
- McD’s 3 fire trucks (one is ATV) and ~20 volunteer fire fighters provide quick initial response



UT/McD Safety Management (3)



◆ Snow and Ice

- Roads, walkways and gantries are plowed/de-iced as needed

◆ Weather

- Safety Officer monitors potential events (lightning, wind, hail, smoke, snow/ice)
- Safety Officer sets off warning siren in case of dangerous weather

◆ Safety Equipment

- First aid kits, AED, fire alarms, fire extinguishers, siren
- Routinely examined/tested; replaced, when appropriate



University/Observatory Resources



- ◆ UT-EHS Comprehensive Health & Safety programs
- ◆ Personal Protective Equipment (PPE) programs and training for general site and site-specific preparedness
- ◆ Routine UT-EHS on-site inspections
- ◆ Environmental Protection Improvements, as needed
- ◆ Safety Training and Educational Courses
 - UT on-line; McD on-site; West Texas regional sources



NASA and UT Safety Issues



- ◆ SGSLR designed and built at GSFC following relevant NASA Health and Safety Standards and Regulations.
- ◆ University of Texas Safety Plans and the State of Texas regulations govern the operations at McDonald Observatory
- ◆ RESOLUTION OF POSSIBLE CONFLICTS between UT and NASA health and safety standards
 - *The higher standard controls*



MGO Personal Hazard Assessment



Hazard Description	Hazard Category	Planned Hazard Controls
Personnel exposure to laser	Non-ionizing radiation exposure (indoor & outdoor)	Interlocks, signage (SGSLR design); SGSLR detection system triggers McD H & S protocols
Aircraft exposure to laser	Non-ionizing radiation exposure (outdoor)	Radar, beam block (SGSLR design & proper maintenance)
Electrical hazard exposure > 50 volts	Electrical discharge (arc) or Electrical shock	All installation per NEC; LOTO procedures, guarding; no live electrical work except (in rarest occasions) according to NFPA 70E protocols
Personnel exposure to radar	Radio Frequency exposure (outdoor)	SGSLR detection system triggers McD H & S protocols
Personnel exposure to fall hazard	Collision/Impact	Handrails, regular inspections by EHS and site safety personnel; snow/ice/etc clearance
Single person operation of the system	Incapacitation of operator	Commissioning: Personnel in adjacent MLRS Operation: TBD (likely: assigned UT personnel)
Hygiene	Toilet and washing facilities	Observatory H & S protocols provide for custodial services on prescribed schedule
Local varmints & vermin	Personnel awareness	Sighting triggers Observatory H & S protocols



Health & Safety Philosophy



1. A health and safety plan is not static
2. It is a changing and evolving document
3. Changes and improvements will take place as needed
4. MGO is a partnership (University, Observatory, NASA)
5. In the event of conflicts, the higher standard controls



Safety at NGO

Are Færøvig (NMA)



Ny-Ålesund Safety



- ◆ Presentation by NMA



Configuration Management and Quality Assurance



Configuration Management



- ◆ CM will identify and track the configuration of the products (HW, SW, other) throughout the build, operations and maintenance phases of the project
- ◆ Develop a system baseline for all configuration items (CIs) which consists of hardware and software
- ◆ CM will track any and all changes to the system baseline by subsystem and system during the product lifecycle, preserving the records for ease in upgrade and maintenance
- ◆ This is done by establishing
 - configuration management strategies and policies
 - identifying baselines of what will be under CM
 - maintaining status of configuration documentation and databases
 - conducting configuration audits
- ◆ Tools include
 - GIT for software CM
 - TDMS for documents (Requirements, Operating Plans, Drawings, WOAs, etc)
 - TDMS for Hardware – baseline established with as-built hardware



SGSLR Quality Assurance



- ◆ The Quality Assurance (QA) program for the SGSLR Project will provide the following:
 - Ensures that the quality requirements are determined and satisfied through the design, development, fabrication, integration, testing, deployment and commissioning of the SGSLR at the GGAO, MGO and NGO sites.
 - Provides for the detection of existing or potential deficiencies.
 - Provides timely and effective remedial and preventive action.
- ◆ QA provides a verification that the project is meeting the requirements and specifications set forth in the project.
- ◆ QA will be part of larger SGSLR team – that is not performing the design/build/test of the component or subsystem.



SGSLR QA Activities



- ◆ Identification and Traceability of parts, components, subsystems and systems
- ◆ Procurement
 - Source Inspection
 - Receiving Inspection
- ◆ Control of fabrication activities
 - Fabrication and Inspection
 - Evaluation and control of process specifications and procedures
- ◆ Non-Conformance Control
 - Reporting and disposition of non-conformance
- ◆ Control of fabrication, inspection and test
 - Build to released documents and specification
 - Inspect and document during fabrication and test
- ◆ Follow and verify all activities to the Verification Matrix
- ◆ Maintain all records within CM function



Path to Pre-Ship Review



Path to PSR for MGO & NGO



- Complete the SGSLR site construction and shelter builds at GGAO and MGO
- NMA to complete shelter and site modifications for SGSLR
- Complete FAT and SAT for all GTA's
- Install required subsystems at McDonald for GTA testing
- Deploy GTA and required subsystems to Ny-Ålesund for GTA testing
- Conduct reviews for Receiver, Laser Safety and Computer and Software subsystems
- Finish procurement of domes, radar, and Laser and MET subsystems
- Complete ground testing of Receiver subsystem and procure / build units 1 & 2
- Build units 1 and 2 of Range Control Electronics (OB and RCE unit 1 nearing completion) and Time and Frequency, Optical Bench, and Laser Safety Subsystems
- Develop software builds required for I&T, collocation and commissioning
- Successfully perform collocations for SGSLR units 1 & 2 at GGAO with MOB-7
- Complete the documentation needed for PSR



Schedule and Risks



Schedule (1 of 2)



8/20/2018

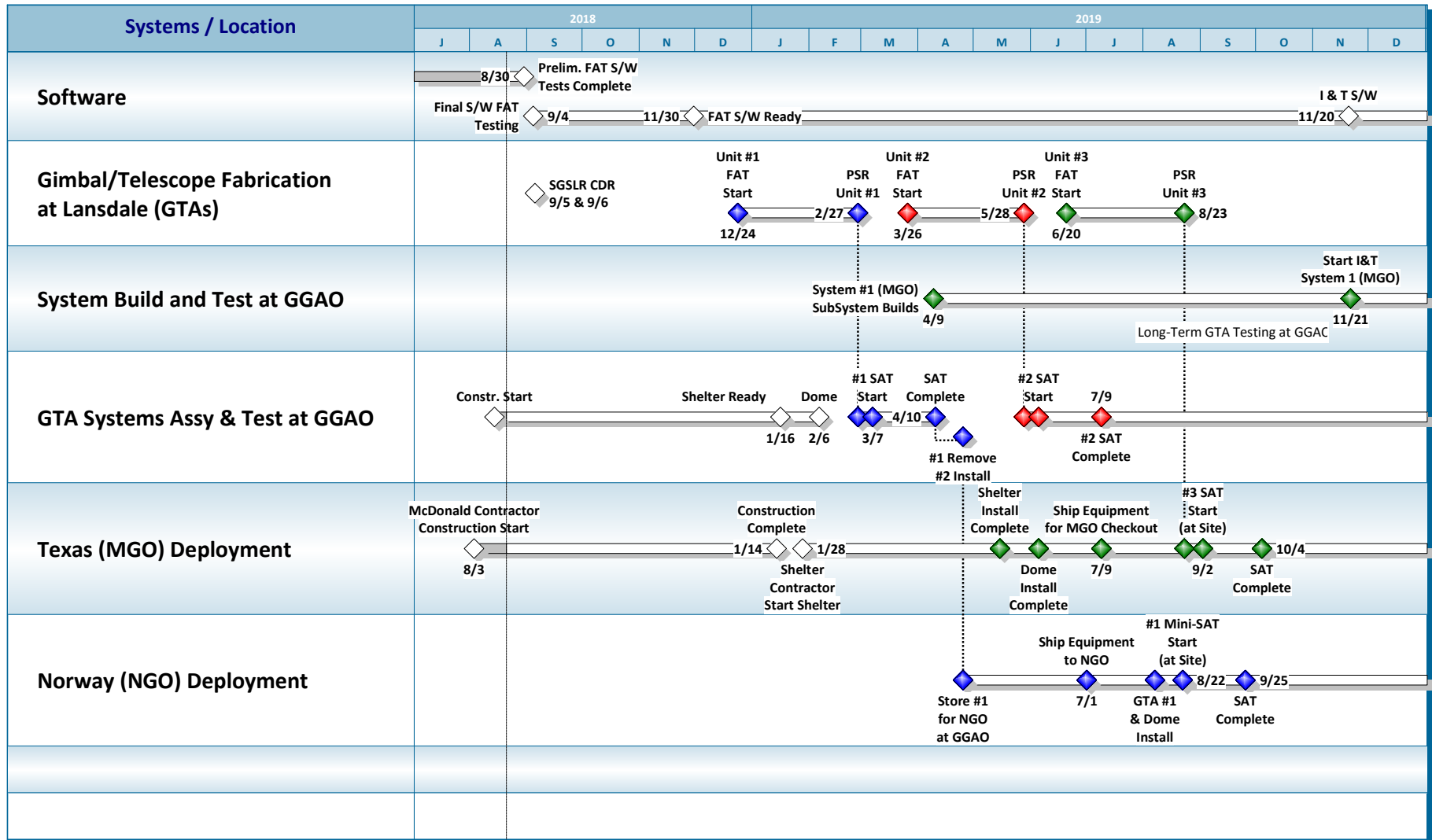



Schedule (2 of 2)



8/20/2018

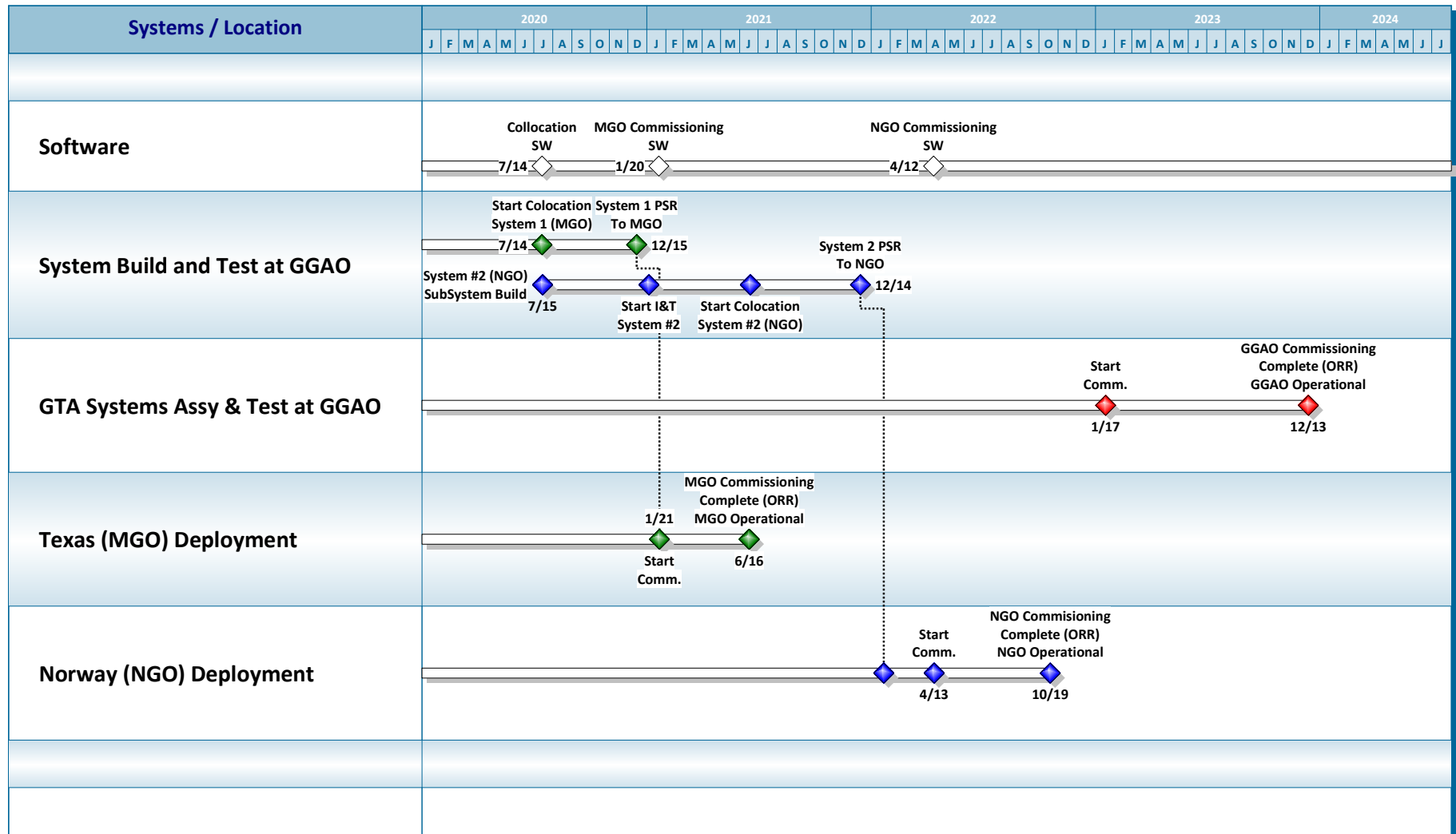



SGSLR Risk List Related to this CDR

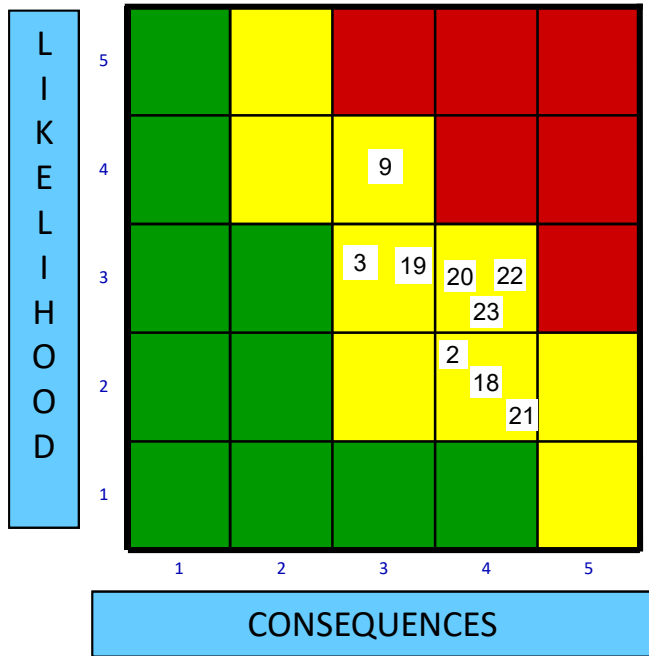

Rank	ID	L x C	Approach	Risk Title
1	R09	↑	Mitigate	Gimbal & Telescope Delivery
2	R23	★	Mitigate	Concurrent distributed work across global sites with limited manpower
3	R22	★	Mitigate	Receiver Performance
4	R20	-	Mitigate	NASA HQ Laser Safety Review Board
5	R19	-	Mitigate	Increased IT Security requirements
6	R03	-	Mitigate	Laser reliability
7	R02	-	Mitigate	Automated closed loop tracking
8	R18	-	Mitigate	SGSLR performance in the Ny-Ålesund winter
9	R21	↓	Mitigate	Ny-Ålesund site stability

Criticality	L x C	Trend	Approach
High	↓	Decreasing (Improving)	Mitigate
Med	↑	Increasing (Worsening)	Watch
Low	-	Unchanged	Accept
	★	New this Month	Research

Risks shown here are related to:

- System Performance
- Local Operations
- MGO and NGO

Receiver Performance is new because it was separated from the Closed Loop Tracking risk



Compliance Matrix: Level 3 Reqs (1 of 2)



SGSLR #	Description	Verification Method	Level	Where verified	How verified?	Compliant?
Functional requirements						
SLF 3.1	With a standard clear atmosphere or better, SGSLR stations shall be capable of 24 x 7 tracking of satellites whose arrays satisfy the ILRS retro-reflector guidelines, and whose altitudes are 300 km to 22,000 km.	TEST	System	Field	Measure/estimate atmospheric transmittance; Collect Operations data on ILRS compliant satellites on a 24x7 schedule to verify operational compliance.	
SLF 3.1.1	With a standard clear atmosphere or better, SGSLR stations shall be capable of tracking geosynchronous satellites whose arrays satisfy the ILRS retro-reflector guidelines.	ANALYSIS	System	Field	Measure/estimate atmospheric transmittance; From MOBILAS-7 use link analysis based on LAGEOS and GNSS ranging to verify compliance	
Baseline performance requirements						
SLBP 3.1	Data precision for LAGEOS NPT shall be < 1.5 mm when averaged over a one month period.	TEST	System	Field	Perform day & night laser ranging to LAGEOS-1 and 2 ensuring all pass geometries are met. Compute the Normal Points externally from SGSLR using full rate data and verify onsite NPT generation. Compute the mean of the precision of all NPTs over a 30 day period and verify compliance.	
SLBP 3.2	The LAGEOS Normal Point range bias shall be stable to 1.5 mm over 1 hour.	TEST	System	Field	Collect laser ranging data as in SLBP 3.1 above, and compute range bias for LAGEOS-1 and 2 for stand alone (against an orbit) and collocated (compared with a nearby SLR system) modes. Compute the RMS of the SGSLR NPT range biases and verify compliance.	
SLBP 3.3	Over one year the RMS of station's LAGEOS NPT range biases shall be < 2mm.	ANALYSIS	System	Field	Compute Range Bias for LAGEOS-1 & LAGEOS-2 as described in SLBP3.2; Compute a global mean and RMS for the 1 year range bias data; If there is insufficient data, do the extrapolation over the 1 year period; Compare the monthly mean of the RB data against the global mean; establish that the RMS is within the requirement.	
SLBP 3.4	SLBP3.4: SGSLR Station shall be capable of producing an annual volume of 45,000 LEO, 7,000 LAGEOS and 10,000 GNSS NPTs.	TEST	System	Field	Collect LEO, LAGEOS and GNSS data over a 4+ month period to study variations for day, nights, seasonal, and atmospheric conditions by operating the station under "field like conditions"; Verify the annual NPT production yield is met.	



Compliance Matrix: Level 3 Reqs (2 of 2)



SGSLR #	Description	Verification Method	Level	Where verified	How verified?	Compliant?
SLBP 3.5	Normal Point time of day shall be accurate to < 100 ns RMS.	TEST	System	Field	Use separate timing devices with accuracy better than station time; Compare device times; Details of process TBD	
SLBP 3.6	Systems shall have a modular design supporting maintenance and upgrades.	ANALYSIS	System	Field	Modularity will be analyzed based on component specifications, subsystem level ICDs, and software design.	
SLBP 3.7	Systems shall be capable of local and remote operation by an operator with a path to full automation.	TEST, ANALYSIS	System	Field	Local and remote operation will be verified by comparing the data performance in either modes by placing the system in the proximity of a standard. The path for automation will be verified by analysis examining the complexity, cost, and potential complications for accomplishing a safe and well performing SLR system.	
SLBP 3.7.1	Systems and operations shall satisfy local and NASA safety requirements.	TEST, ANALYSIS	System	Field	Verify compliance with NASA and FAA safety by review of laser safety paperwork; Verify laser safety for indoor and outdoor transmission by analysis, measurement, and strict procedural compliance; Verify aircraft avoidance system performance compliance through ground-based/airborne targets.	
SLBP 3.7.2	Systems shall be capable of following ILRS procedures and formats and handle ILRS-defined restricted tracking.	TEST, ANALYSIS	System	Field	Check that data formats, site log, system procedures are in compliance with ILRS; Check for a period of a month that all data is getting to Operations Center in the time required; Run through all restricted tracking tests to ensure compliance.	
SLBP 3.8	SGSLR Stations shall not introduce any unquantified biases into the legacy SLR network.	ANALYSIS	System	Field	Apply a priori established range corrections unique to the systems in test; Estimate a mean and RMS for range and time bias (RB, TB) from the observed data using (1) POD, and (2) comparison against a nearby and well characterized SLR system; Compute RB and TB for L1 and L2 satellites from orbit and collocation; Verify the RB and TB comply for all pass geometries.	

SLBP 3.7 will fully comply with requirements by ORR



Success Criteria Tailored (NPR 7123.1B) (1 of 2)



- ✓ The detailed design is expected to meet the requirements with adequate margins.
- ✓ Interface control documents are sufficiently mature to proceed with fabrication, assembly, integration, and test, and plans are in place to manage any open items.
- ✓ High confidence exists in the product baseline, and adequate documentation exists or will exist in a timely manner to allow proceeding with fabrication, assembly, integration, and test.
- ✓ The product verification requirements and plans will be completed in a timely manner.
- ✓ The testing approach is well understood, and the planning for system assembly, integration, test, and site commissioning and operations is sufficient to progress into the next phase.
- ✓ Risks to mission success are understood and credibly assessed, and plans exist to manage them.
- ✓ Safety and reliability have been adequately addressed in system and operational designs, and any applicable safety and reliability products meet requirements, are at the appropriate maturity level for this phase of the program's life cycle, and indicate that the program safety/reliability residual risks will be at an acceptable level.



Success Criteria Tailored (NPR 7123.1B) (2 of 2)



- ✓ The project has demonstrated compliance with NASA requirements, standards, processes, and procedures for IT Security and Safety.
- ✓ There are no TBD and TBR items in the level 3 and 4 requirements.
- ✓ Engineering test units and modeling and simulations have been developed and have been or are being tested per plan.
- ✓ The operational concept has matured, is of sufficient detail, and has been considered in test planning.
- ✓ Manufacturability has been adequately included in design (and presented in more detail at EPRs).
- ✓ Software design has matured significantly since PDR. The software is ready to progress to next phase. And continued development during this next phase will produce mature design, hazard analysis, and testing process.



SUMMARY



- ◆ The SGSLR design meets the performance requirements as shown through analysis, simulation and testing (lab, NGSLR).
- ◆ SGSLR system design has matured significantly since PDR:
 - Most subsystems are being built (MET, DSPR, GTA, Laser, T&F, OB, C&S)
 - Peer reviews for receiver, laser safety, and computer & software to be scheduled
- ◆ We are tailoring our processes to prioritize the performance requirements for a ground instrument.
- ◆ The critical path of the schedule is driven by existing procurement contracts (GTA, shelter) and agreements (Norway).
- ◆ The SGSLR team is limited in size and cannot be distributed over the globe all at the same time. This remains a challenge to be resolved.