

Ground Based Space Geodesy Networks Required to Improve the ITRF

Michael Pearlman

Harvard-Smithsonian Center for Astrophysics
Cambridge MA USA
mpearlman@cfa.harvard.edu

Erricos Pavlis

University of Maryland
Baltimore MD USA

Chopo Ma

NASA GSFC
Greenbelt MD USA

Zuheir Altamimi

Institut Geographique National
Champs-sur-Marne, France

Carey Noll

NASA GSFC
Greenbelt MD USA

David Stowers

Jet Propulsion Laboratory/California Institute of Technology
Pasadena CA USA



Workshop on Satellite, Lunar, and Planetary Laser Ranging:
Characterizing the Space Segment
Frascati, Italy
November 5 - 9, 2012

Some people think the Earth looks like this:



But really it looks like this:

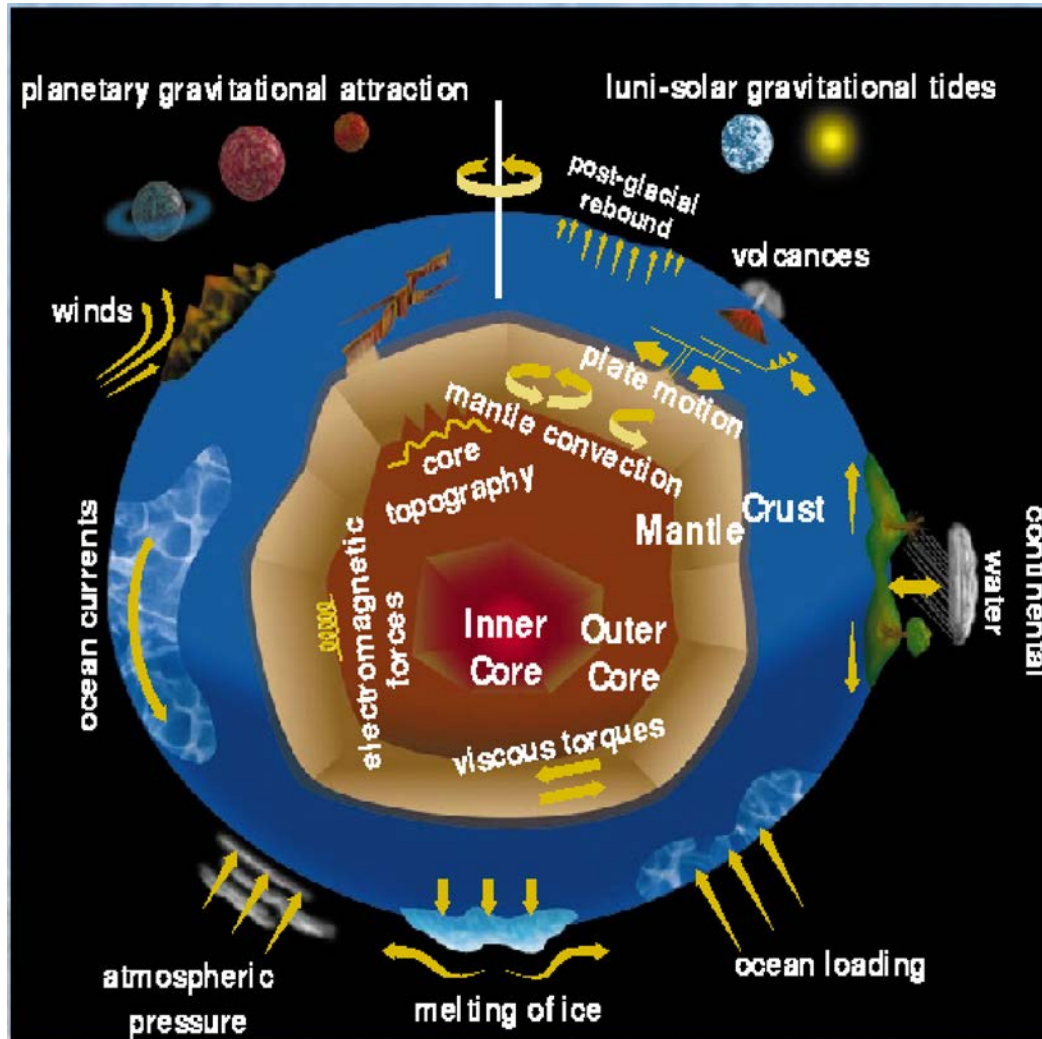

Motivation: Monitoring the Earth System



Pillar 1: Geometry and Deformation of the Earth

- Problem and fascination of measuring the Earth:

Everything is moving !

- Monitoring today mainly by GPS permanent networks

- Examples:

- Plate motions
- Solid Earth tides (caused by Sun and Moon)
- Loading phenomena (ice, ocean, atmosph.)
- Earthquakes ...

- **Continuous monitoring is absolutely crucial**

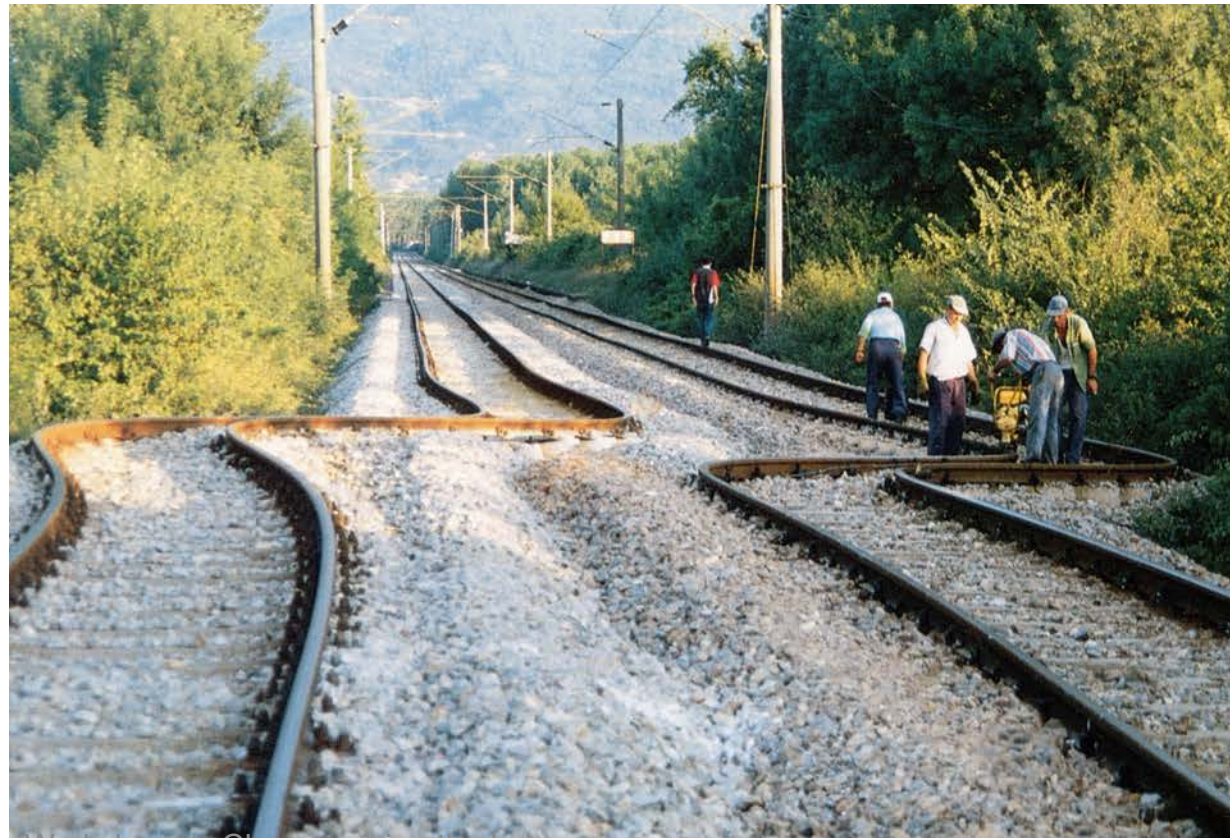

Workshop on Characterizing the Laser
Ranging Space Segment
Frascati, Italy

Measure Sea Surface Height with Altimetry

- What kinds of things effect Sea Level?
 - Water Volume
 - Water temperature
 - Tides
 - Currents
 - Tsunamis
 - Weather
 - Coast Line. etc

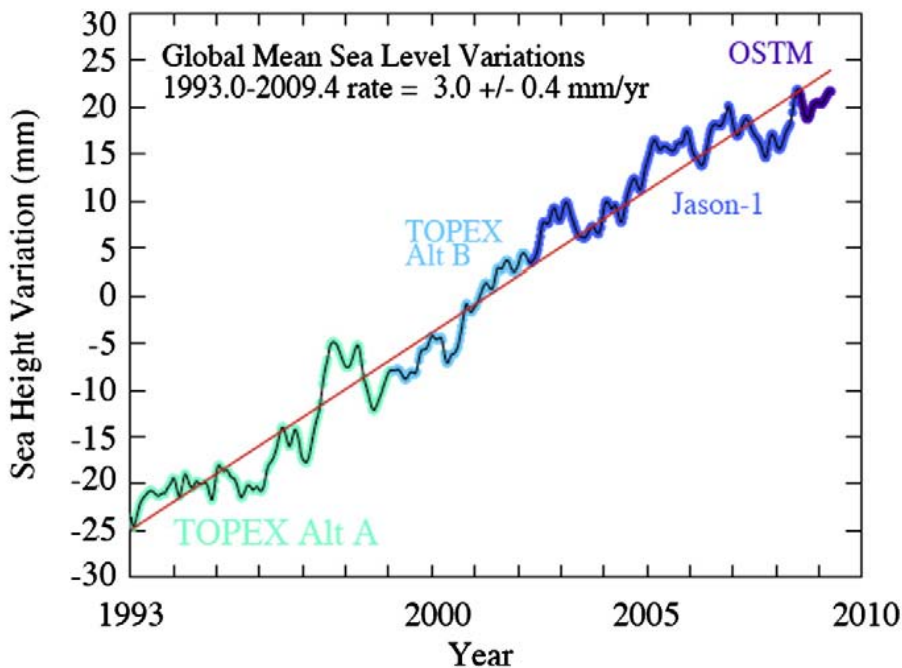
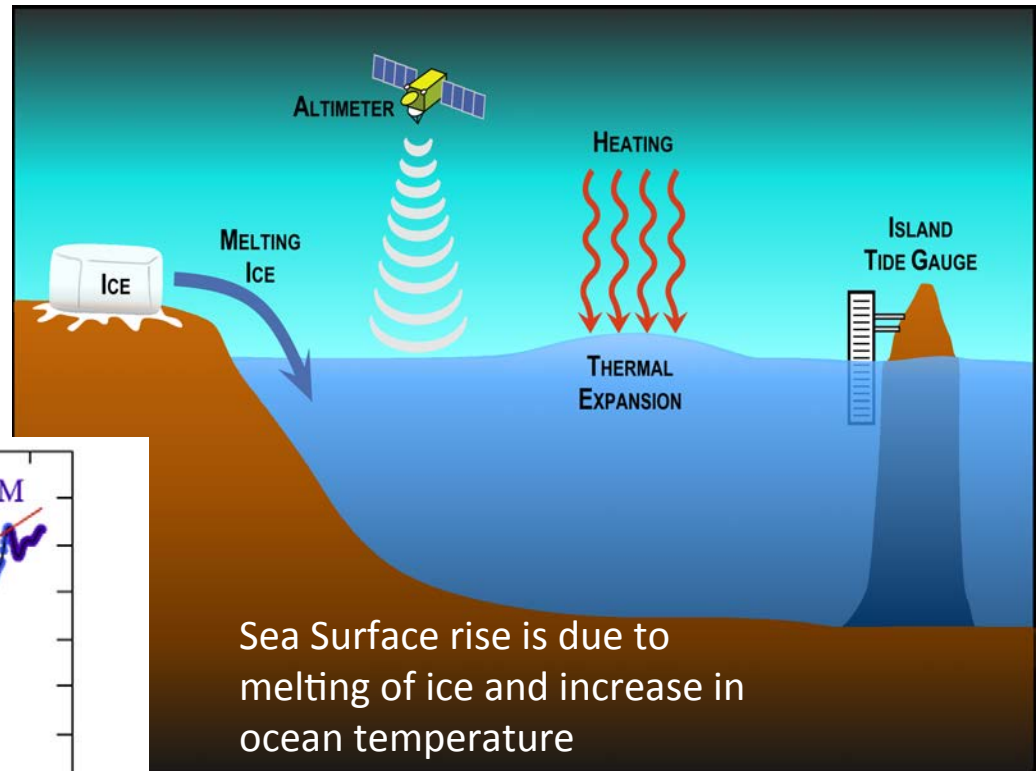

Source: Lemoine, F.G., et al. Towards development of a consistent orbit series for TOPEX, Jason-1, and Jason-2. J. Adv. Space Res. (2010), doi:10.1016/j.asr.2010.05.007

GGOS and the EOP

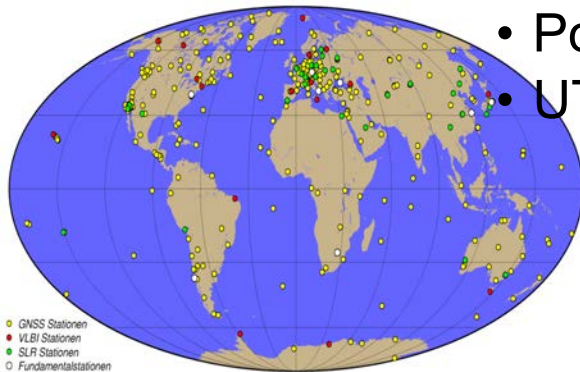
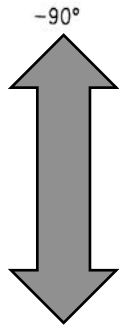
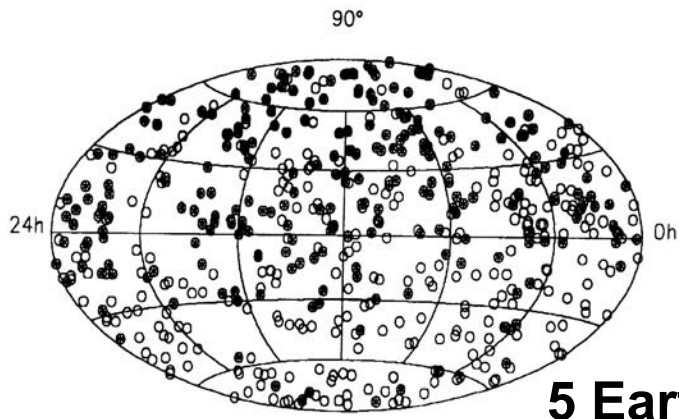

● GNSS Stationen
● VLBI Stationen
● SLR Stationen
○ Fundamentalstationen

5 Earth orientation parameters (EOP) required for any positioning and navigation:

- Precession/nutation
- Polar motion
- UT1 - UTC (or Iod)

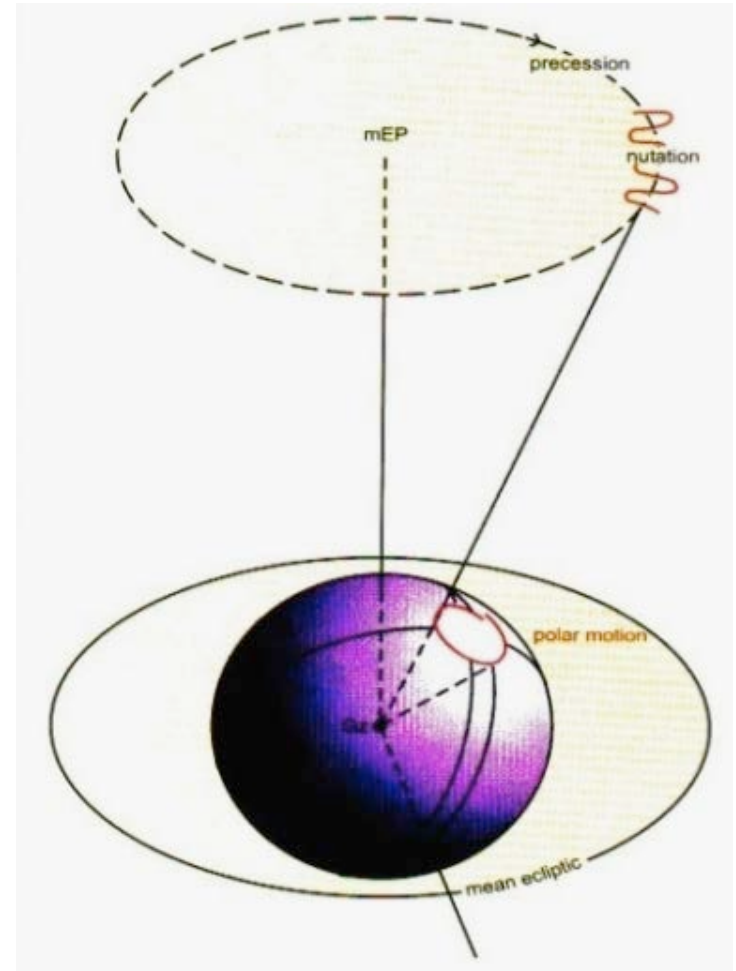

Pillar 3: Gravity Field, Mass Transport

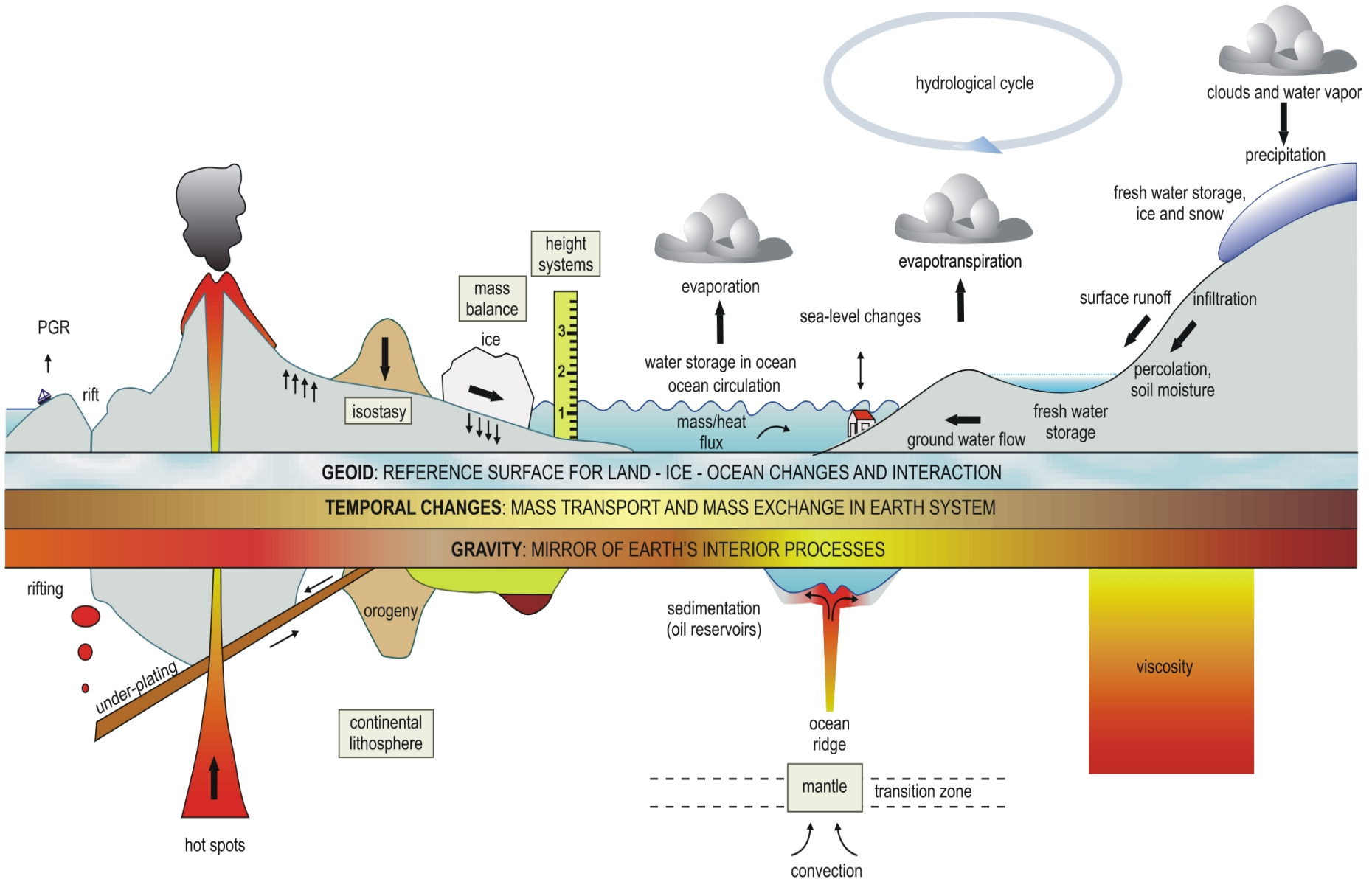

Ilk et al. (2005) Mass Transport and Mass Distribution in the Earth System, 2nd Edition, SPP1257 DFG

Nov. 5 - 9. 2012

Ranging Space Segment
Frascati, Italy

2009 Amazon Flooding

From Prof. C. K. Shum, OSU

Feb. 1, 2009

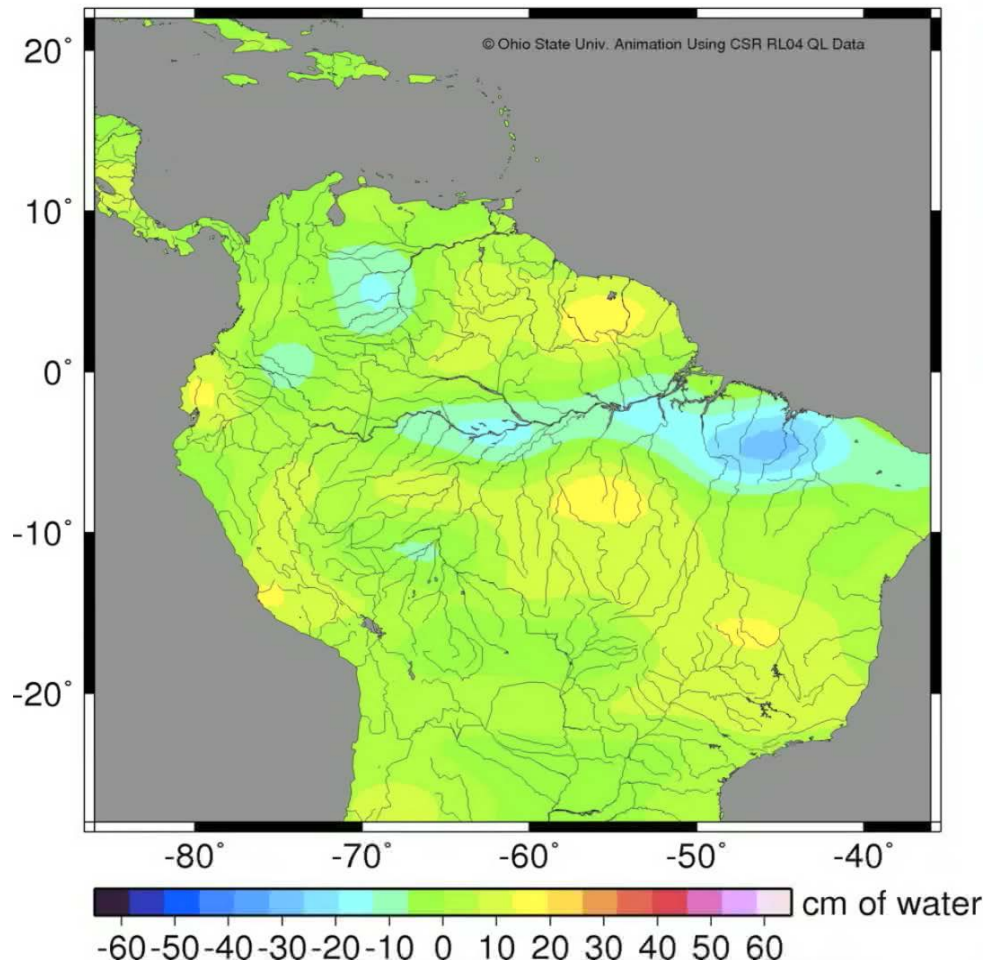

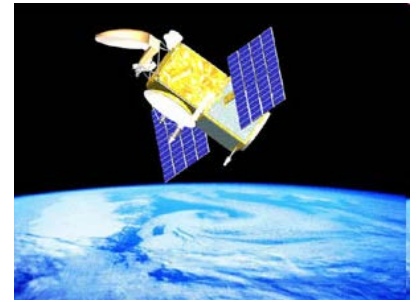
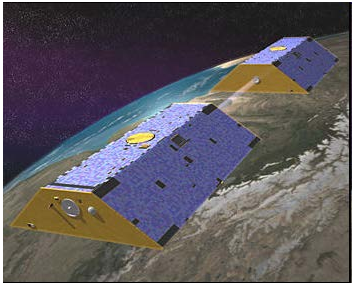

Common Thread:

- Reference Frame
- Precision Orbit Determination

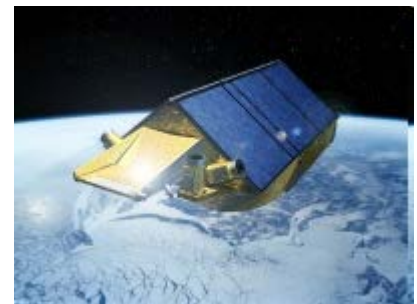

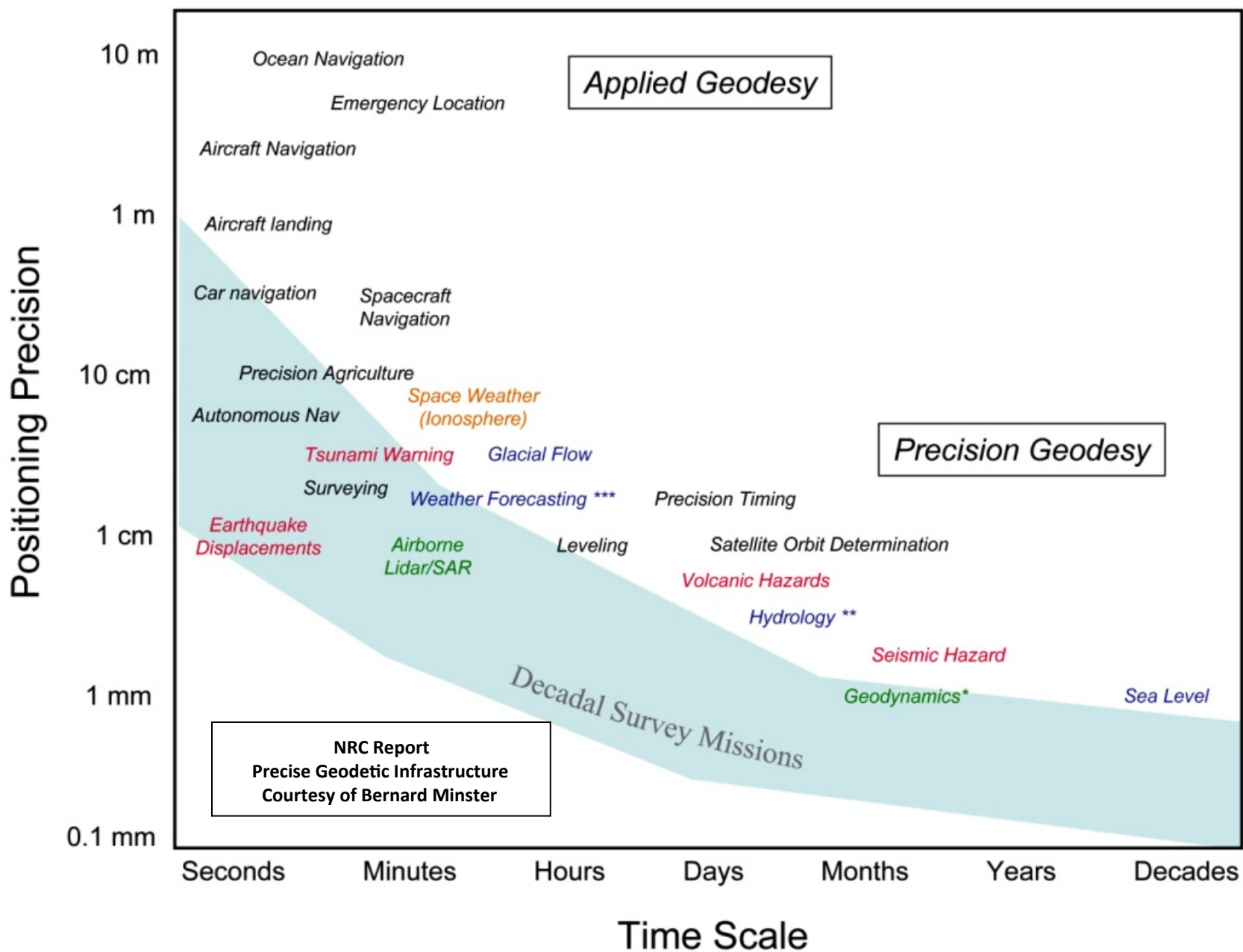

NRC Report
 Precise Geodetic Infrastructure
 Courtesy of Bernard Minster

When National Reference Frames are not integrated!

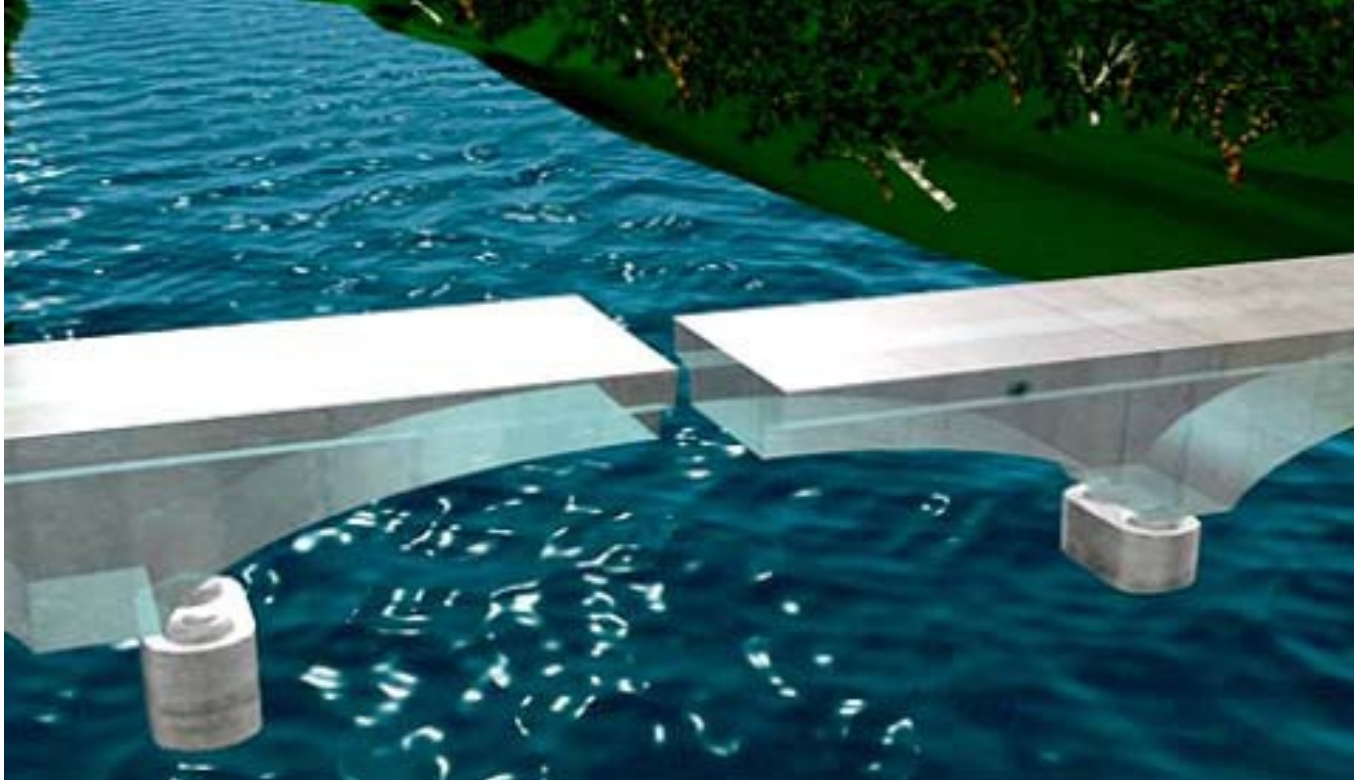

Design error at bridge construction in Laufenburg (2003): During the construction of the bridge across the Rhine river in Laufenburg, a control showed that a height difference of 54 centimeters exists between the bridge built from the Swiss side and the roadway of the German side. Reason of the error is the fact that the horizons of the German and Swiss side are based on different reference frames. Germany refers to the sea level of the North Sea, Switzerland to the Mediterranean.

International Terrestrial Reference Frame (ITRF)

- Provides the stable coordinate system that allows us to measure change (link measurements) over space, time and evolving technologies.
- An accurate, stable set of station positions and velocities.
- Foundation for virtually all space-based and ground-based metric observations of the Earth.
- Established and maintained by the global space geodetic networks.
- Network measurements must be precise, continuous, robust, reliable, and geographically distributed (worldwide).
- Network measurements interconnected by co-location of the different observing techniques at CORE SITES.

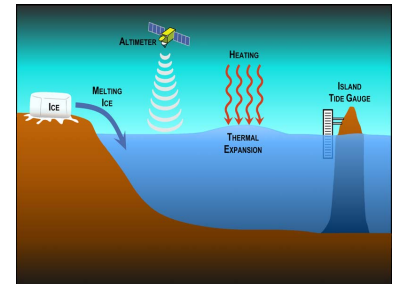

Global Geodetic Observing System (GGOS)

IAG Bylaws 1(d)

“The Global Geodetic Observing System is an element of the IAG that works with the IAG components to provide the geodetic infrastructure necessary for monitoring the Earth system and global change research.”

The vision of GGOS is

“Advancing our understanding of the dynamic Earth system by quantifying our planet’s changes in space and time.”

Major Item: *Provide the infrastructure to maintain and improve the reference frame to meet future needs*

The International Terrestrial Reference Frame is established by the Global Space Geodesy Networks

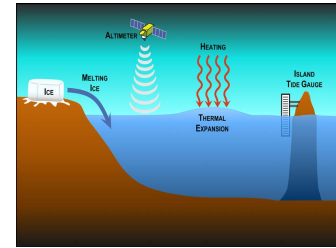

Requirement (Source GGOS 2020):

<1 mm reference frame accuracy

< 0.1 mm/yr stability

- Measurement of sea level is the primary driver
- Improvement over current ITRF performance by a factor of 10-20.

Means of providing the reference frame:

- Global Network of co-located VLBI/SLR/GNSS/DORIS CORE SITES;
- Dense network of GNSS ground stations to distribute the reference frame globally to the users

Requirement: Users anywhere on the Earth can position their measurements in the reference frame at any time

GGOS 2020 Book (2009)

GGOS: Meeting the Requirements of a Global Society on a Changing Planet in 2020.
Eds. H.-P. Plag and M. Pearlman. Springer 2009. p. 332

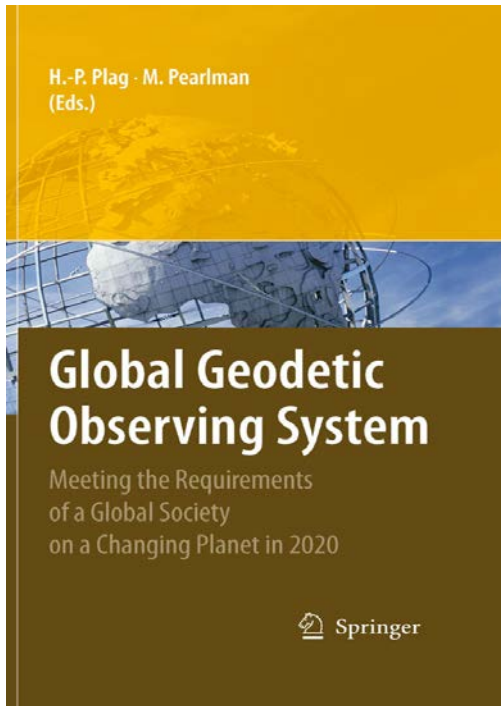

Content: main arguments for GGOS

- Goals, achievements and tools of modern geodesy
- Earth science requirements for geodesy
- Maintaining a modern society (9 societal benefit areas)
- Future geodetic reference frames
- Future Global Geodetic Observing System (GGOS)
- GGOS 2020

GGOS: the Ground-Based Component

VLBI



GPS

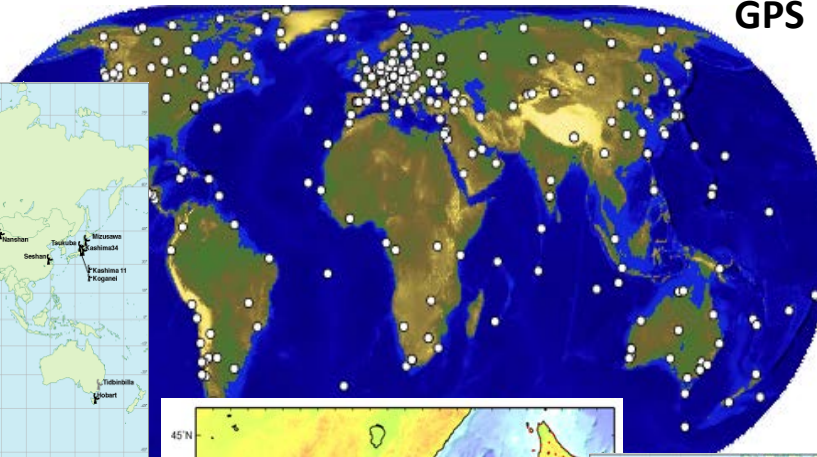

Sup.Grav.

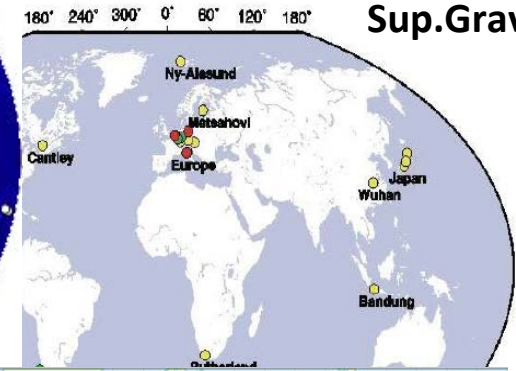

GPS

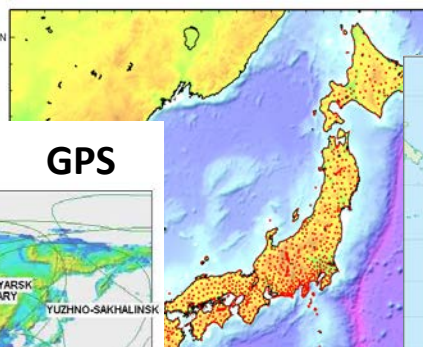

Elevation 12"

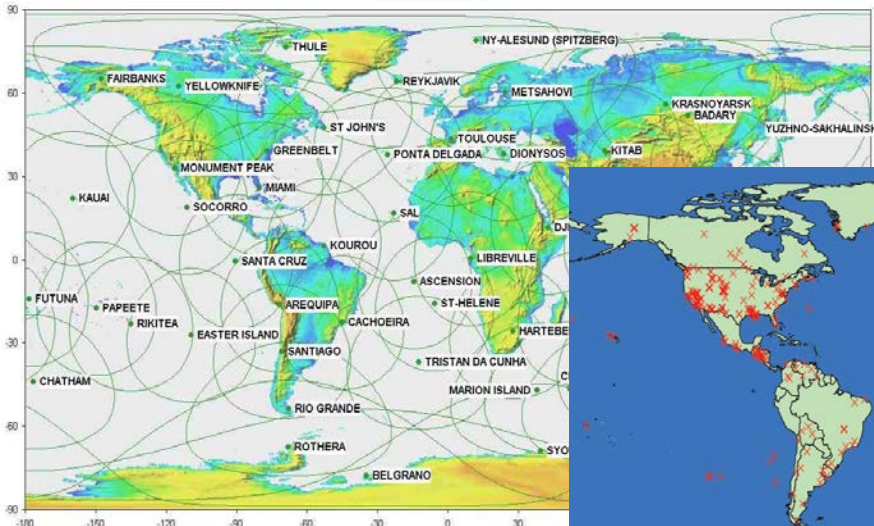

DORIS

Nov. 5 - 9. 2012

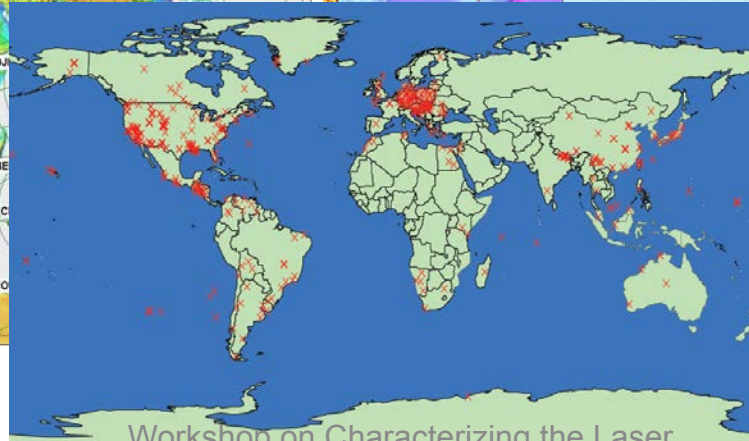

Workshop on Characterizing the Laser Ranging Space Segment
Frascati, Italy

GGOS Role is to combine the networks to support development of integrated products

What is a Core Site?



SLR



VLBI



GNSS



DORIS

- A ground site with co-located SLR, VLBI, GNSS and DORIS (where available) so that their measurements can be related to sub-mm accuracy
- Why do we need multiple techniques?
 - Measurement requirements are very stringent
 - Each technique makes its measurements in a different way and therefore each measures something a little different:
 - Terrestrial (satellite) verses celestial (quasar) reference
 - Range verses range difference measurements
 - Broadcast up verses broadcast down
 - Radio verses optical
 - Active verses passive
 - Geographic coverage
 - Each technique has different strengths and weaknesses
 - The combination (Co-location) allows us to take advantage of the strengths and mitigate the weaknesses

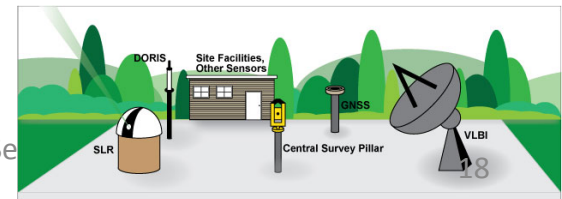

Local Ground Survey is an Essential Part of Co-location



Co-Location System

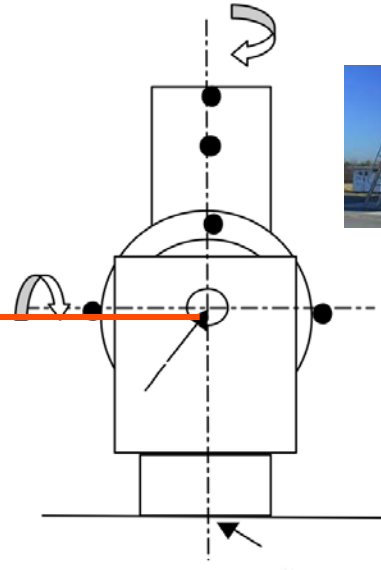
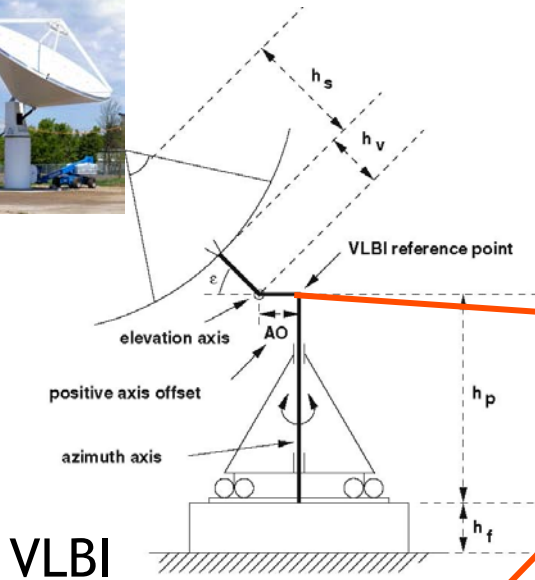

DORIS

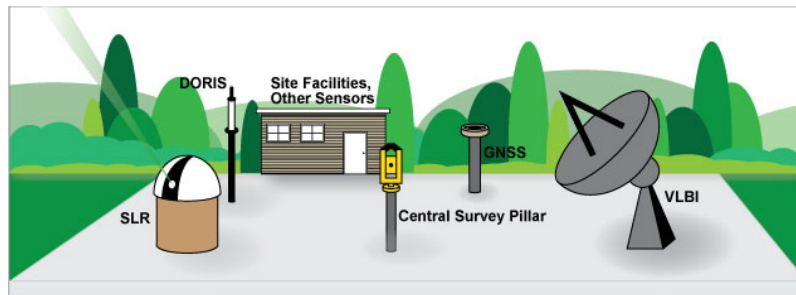
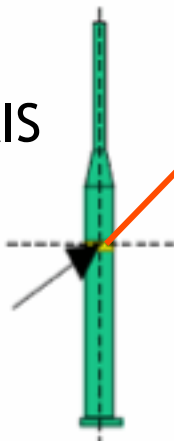

GPS

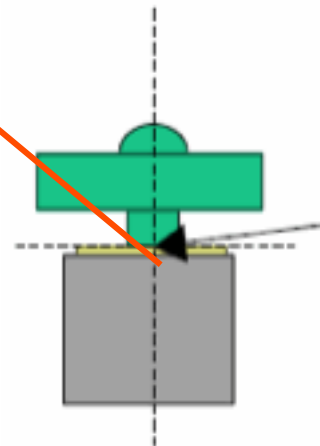

Example Core Site

NASA Goddard Space Flight Center, Greenbelt MD, USA



- Goddard Geophysical and Astronomical Observatory (GGAO) has four Co-located techniques on site:
SLR, VLBI, GPS, DORIS

Concepcion, Chile



Co-location in Space

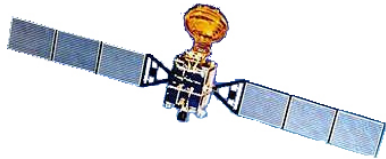

Compass
GNSS/SLR



GLONASS
GNSS/SLR

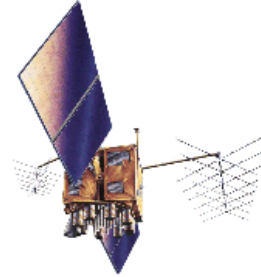

GPS
GNSS/SLR



GIOVE/Galileo
GNSS/SLR

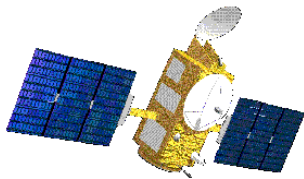

Jason
DORIS/GNSS/SLR



CHAMP
GNSS/SLR

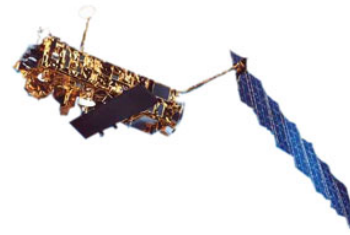

Envisat
DORIS/SLR

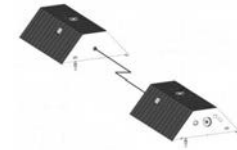

GRACE
GNSS/SLR

Satellite Laser Ranging Technique

Precise range measurement between an SLR ground station and a retroreflector-equipped satellite using ultrashort laser pulses corrected for refraction, satellite center of mass, and the internal delay of the ranging machine.

- Simple range measurement
- Space segment is passive
- Simple refraction model
- Night / Day Operation
- Near real-time global data availability
- Satellite altitudes from 400 km to synchronous satellites, and the Moon
- Cm satellite Orbit Accuracy
- Able to see small changes by looking at long time series

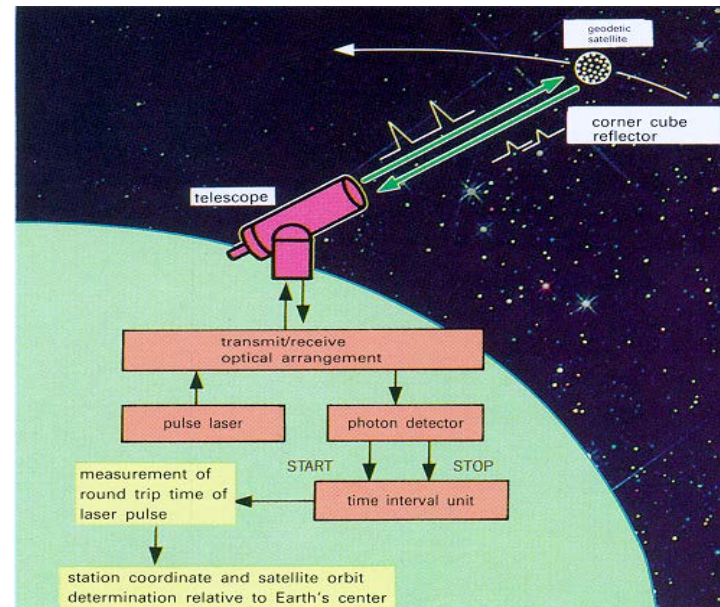

- Only Space Geodesy Technique that measures range directly
- Unambiguous centimeter accuracy orbits
- Long-term stable time series

Co-located VLBI, SLR, GNSS (Some with DORIS)

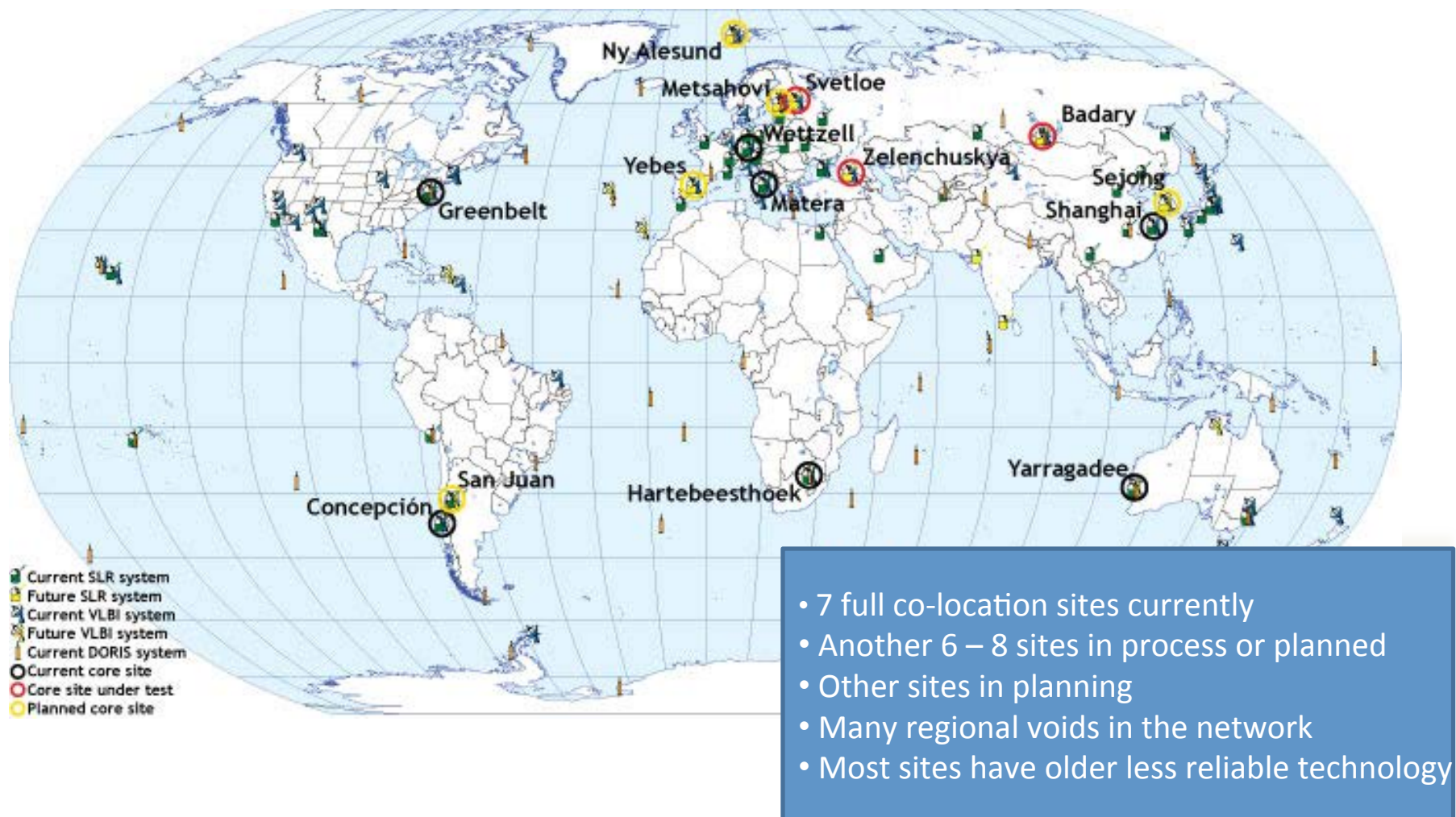

Simulation Studies to Scope the Network

(impact on the Reference Frame)
(Erricos Pavlis)

- Simulations completed
 - ~30 globally distributed, well positioned, co-location Core Sites with modern technology and proper conditions;
 - 16 of these Core Sites must track GNSS satellites with SLR to calibrate the GNSS orbits;
- Simulations underway
 - Sensitivity to intersystem vector accuracy
 - Phased deployment; evolution of the products
 - Impact of errors and outages;
 - Additional space objects
 - Tracking scenarios

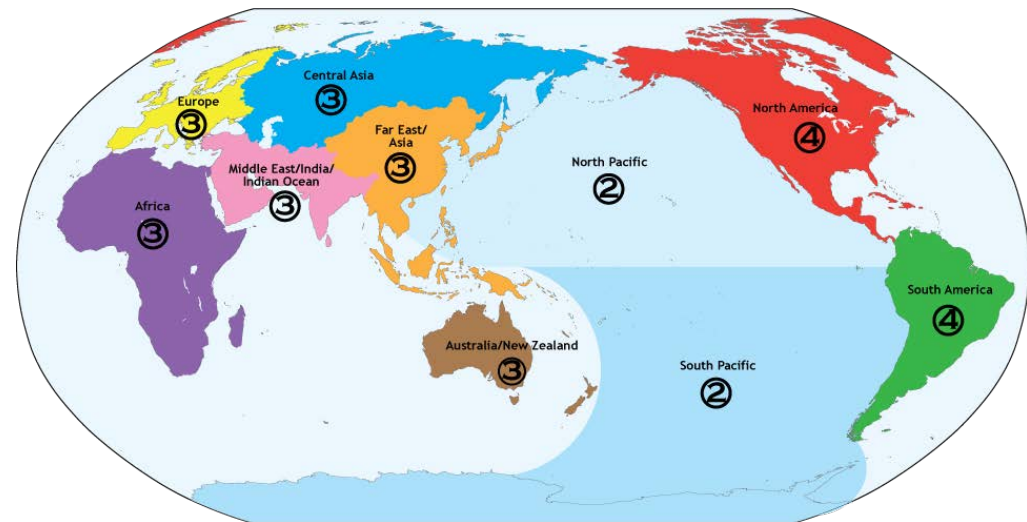

GGOS Site Requirements Document

(http://cddis.gsfc.nasa.gov/docs/GGOS_SiteReqDoc.pdf)



- Introduction and Justification
 - What is a Fundamental Station?
 - Why do we need the Reference Frame?
 - Why do we need a global network?
 - What is the current situation?
 - What do we need?
- Site Conditions
 - Global consideration for the location
 - Geology
 - Site area
 - Weather and sky conditions
 - Radio frequency and optical Interference
 - Horizon conditions
 - Air traffic and aircraft Protection
 - Communications
 - Land ownership
 - Local ground geodetic networks
 - Site Accessibility
 - Local infrastructure and accommodations
 - Electric power
 - Site security and safety
 - Local commitment

Technology

- **The Ground-based Techniques are making progress**
- **Path Forward on the Technology is pretty much known**
- **Improvements are being made in the Space Segment**

Current Trends in Satellite Laser Ranging



- Higher pulse repetition rate (0.1 – 2 KHz) for faster data acquisition;
- Smaller, faster slewing telescope for more rapid target acquisition and pass interleaving;
- Ranging from LEO to GNSS;
- Ranging to Space-born receivers
- More accurate pointing for link efficiency;
- Narrower laser pulse width for greater precision;
- Single photon detection for greater accuracy;
- More automation for economy (24/7);
- Greater temporal and spatial filtering for improved signal to noise conditions;
- Modular construction and more off the shelf components for lower fabrication/operations/maintenance cost;

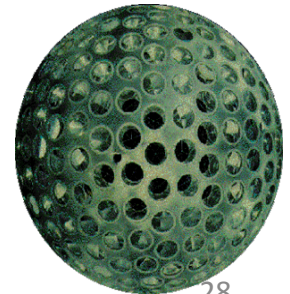

Next Generation VLBI 2010

(Developed within the International VLBI Service (IVS))



- Smaller, faster antennas (~12m) for more rapid target acquisition;
- Unattended operation for expanded temporal coverage;
- Broad continuous frequency range (~2-12 GHz) using multiple bands - smaller observation error;
- Selectable frequency bands RFI avoidance and better accommodation with legacy (S/X) systems;
- Higher speed recording (8 Gbps), for increased sensitivity increased sensitivity - Mark 5C recorder;
- Transfer data with combination of high speed networks and high rate disk systems;
- Standardization and commercial off-the-shelf availability of many parts for lower operating and replicating costs;
- Improved group delay to support ~1 mm position determination;
- Possible use of phase delay for even better precision