

# NGSLR: NASA's Next Generation Satellite Laser Ranging System

Jan McGarry  
Space Geodesy Project  
Solar System Exploration Division

August 2012

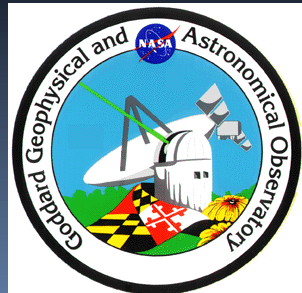

# Satellite Laser Ranging Technique

**Observable:** The precise measurement of the roundtrip time-of-flight of an ultrashort ( $< 500$  psec) laser pulse between an SLR ground station and a retroreflector-equipped satellite which is then corrected for atmospheric refraction using ground-based meteorological sensors.

- **Unambiguous time-of-flight measurement**
- **1 to 2 mm normal point precision**
- **Passive space segment (reflector)**
- **Simple refraction model**
- **Night / Day Operation**
- **Near real-time global data availability**
- **Satellite altitudes from 300 km to 22,000 km (GPS, GLONASS) and the Moon**
- **Centimeter accuracy satellite orbits**  
~ 1-2 cm (LAGEOS) & ~2-3 cm (GPS)

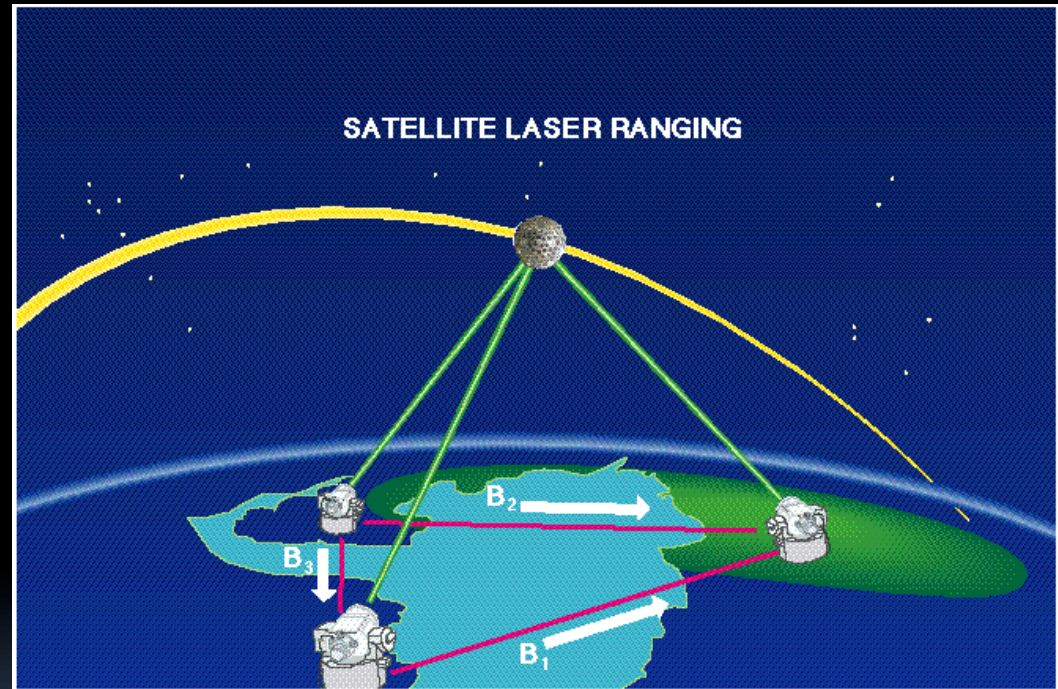

**SLR generates unambiguous centimeter accuracy orbits!**

## Retro-Reflector Array (RRA): GPS 35,36

32 solid cubes – each 28mm

Aluminum coated reflective surfaces

Array shape: planar square

Array size: 239 x 194 x 37 mm

Array mass: 1.27 kg



## Hollow corner cube

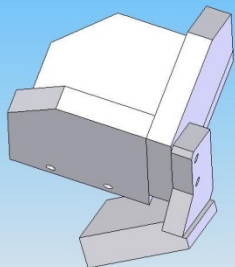

# Corner Cube Reflectors and Arrays

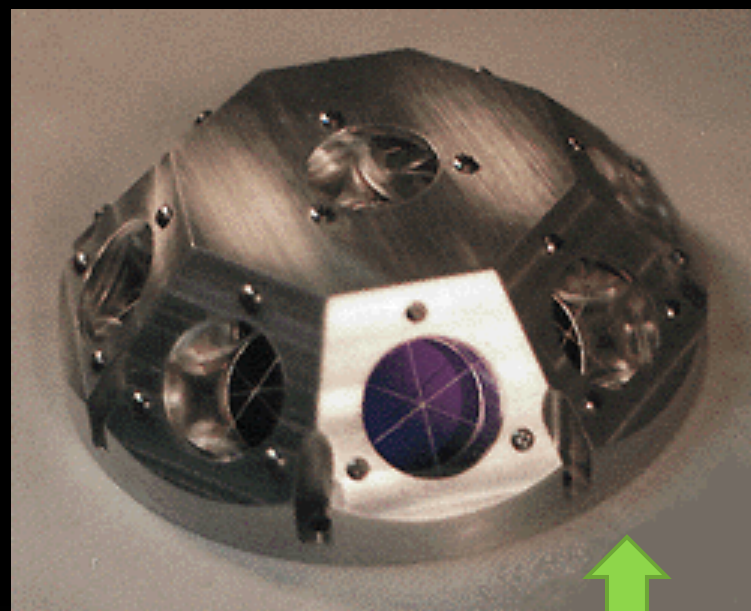

## Retro-Reflector Array (RRA):

**ICESat, JASON, GFO, ADEOS-II**

9 solid cubes – each 32 mm

Research grade radiation resistant suprasil quartz

Silver coated

Array shape: hemispherical (16cm diameter)

Array mass: 731 gm

# Space Missions Tracked by SLR

~70 satellites tracked

Satellite Type:

- Geodetic
- Earth Sensing
- Navigation
- Space Science

Start of the ILRS →

Today →

Satellite Name

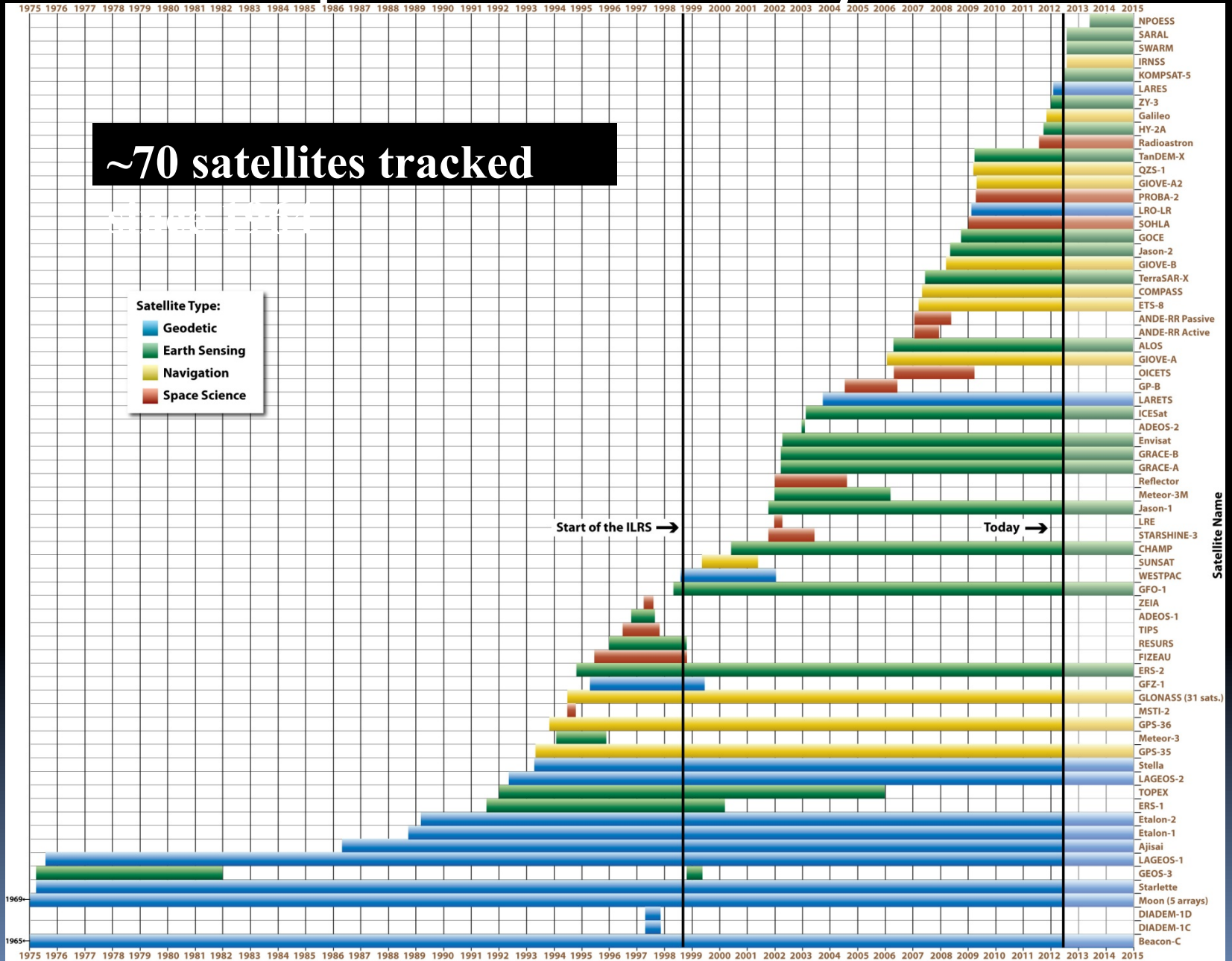



## International Laser Ranging Service (ILRS)

# Lunar Laser Ranging (LLR) to retro-reflectors

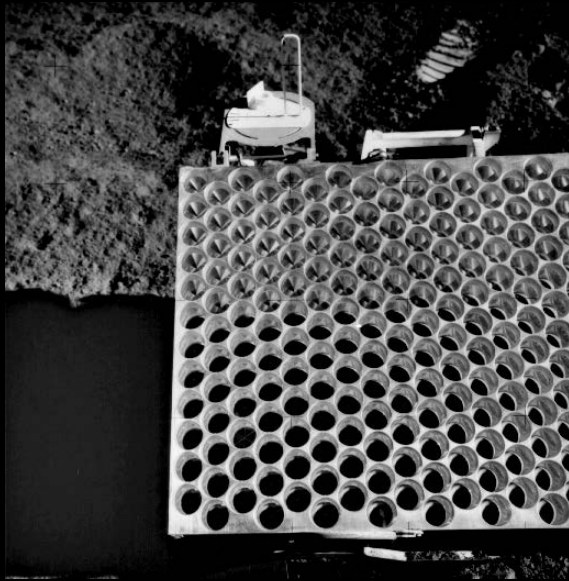

- There are 5 retro-reflectors arrays: 3 Apollo and 2 Luna.

- Apollo RRA's have 3.8 cm cubes. Apollo 11 & 14 have 100, Apollo 15 has 300.

- Regularly tracked by only a few stations. NASA funded University of Texas (MLRS) has successfully ranged continuously since 1970s. Ranges are accurate to a few centimeters.

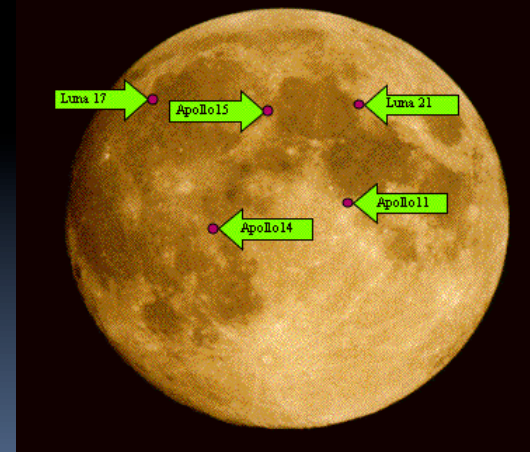
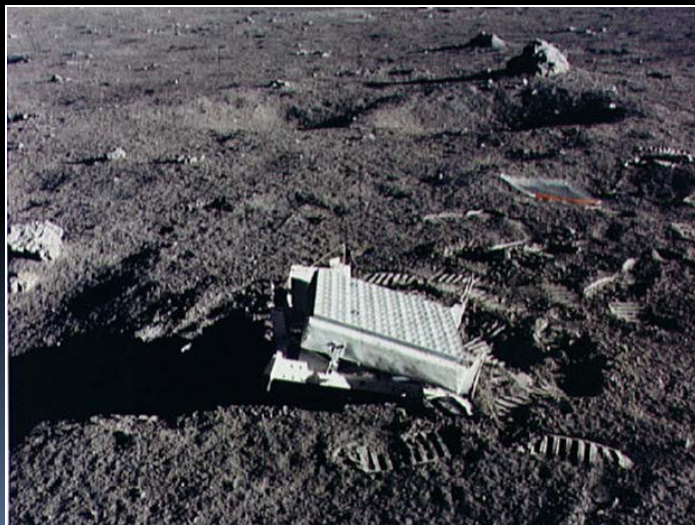

# GSFC records first SLR returns ever on Oct 31, 1964 (GSFC team lead by Henry Plotkin)

## SATELLITE LASER RANGING - 1964

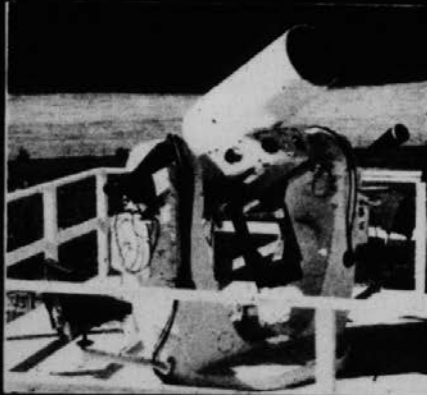

TRANSMITTING LASER AND  
RECEIVING TELESCOPE,  
MOUNTED ON A MODIFIED  
NIKE-AJAX RADAR PEDESTAL.

### GODDARD LASER (GODLAS)

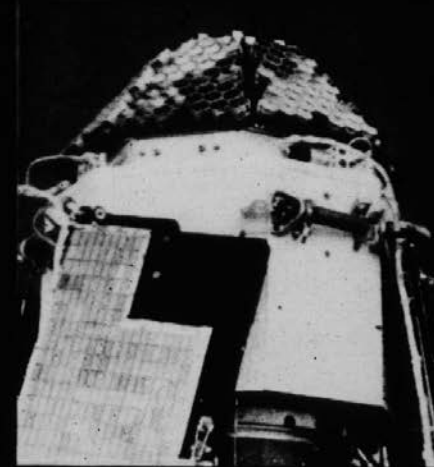

THE BEACON EXPLORER-B  
SATELLITE WITH ARRAY OF  
CUBE-CORNER REFLECTORS.

BE-B: first satellite with  
retro-reflectors

# Goddard Geophysical and Astronomical Observatory (GGAO)

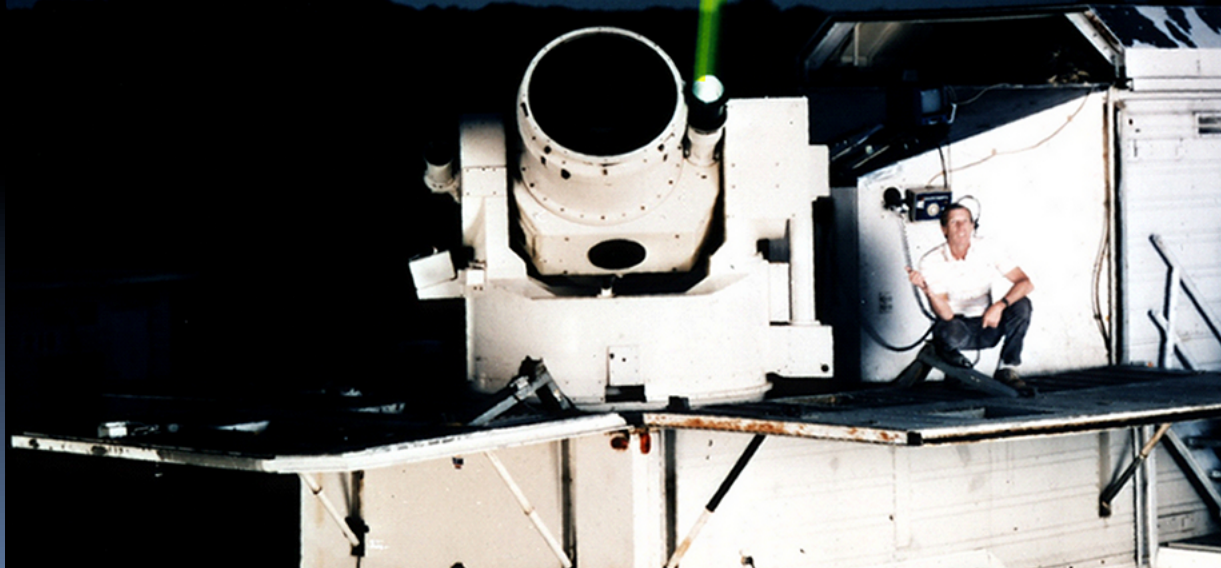

Photo circa 1980

- Located ~ 3 miles from GSFC in middle of BARC on Springfield Road.
- Currently one of only a few sites with all four Geodetic Techniques.
- GGAO has been the site of all NASA SLR system development, testing and colocations. The Italian MLRO system, the Saudi SALRO, German MTLRS, the Japanese GUTS, and other ILRS systems have also been developed and tested at site.



# Current NASA SLR: MOBILAS-7



- Systems built around in late 1970s and still operating.
- 76 cm (30") diameter telescope.
- Laser rep rate: 1,2,4,5,10Hz.
- Wavelength & energy: 532nm, 100mJ.
- 5 systems, all still operating, now located in:

California  
Australia  
South Africa  
Maryland (GGAO)  
Tahiti.

# The Next Generation SLR System

NGSLR is a high repetition rate single photon detection laser ranging system capable of tracking cube corner reflector (CCR) equipped satellites in Earth orbit. The concept of NGSLR was developed by J. Degnan (GSFC, retired) in the 1990s. Technical development continues at Goddard. The system has demonstrated tracking of Earth orbit satellites with altitudes from 300 km to 20000 km. Completion of the NGSLR prototype will occur during the Space Geodesy Project.



## Achievements & Status:

- Successfully tracked most of ILRS satellites.
- LEO, LAGEOS 1 & 2, and GNSS have all been successfully tracked in both daylight and night.
- Preliminary intercomparison testing with MOBILAS-7 completed. Analysis ongoing.
- Installing new optical bench to support use of 2.5 mJ, 2 kHz Photonics Industries laser and to provide required automation.

## System Features:

- 1 to 2 arcsecond pointing/tracking accuracy
- Track CCR equipped satellites to 20,000 km altitude, 24/7 operation
- Single photon detection
- Semi automated tracking features
- Increased accuracy & stability
- Small, compact, low maintenance, increased reliability
- Lower operating/replication costs

# Major Subsystems

1. Time & Frequency
2. Telescope
3. Transceiver Bench
4. Laser
5. Laser Hazard Reduction System (LHRS)
6. Tracking
7. Receiver
8. Computer and Software
9. Weather
10. Shelter and Dome

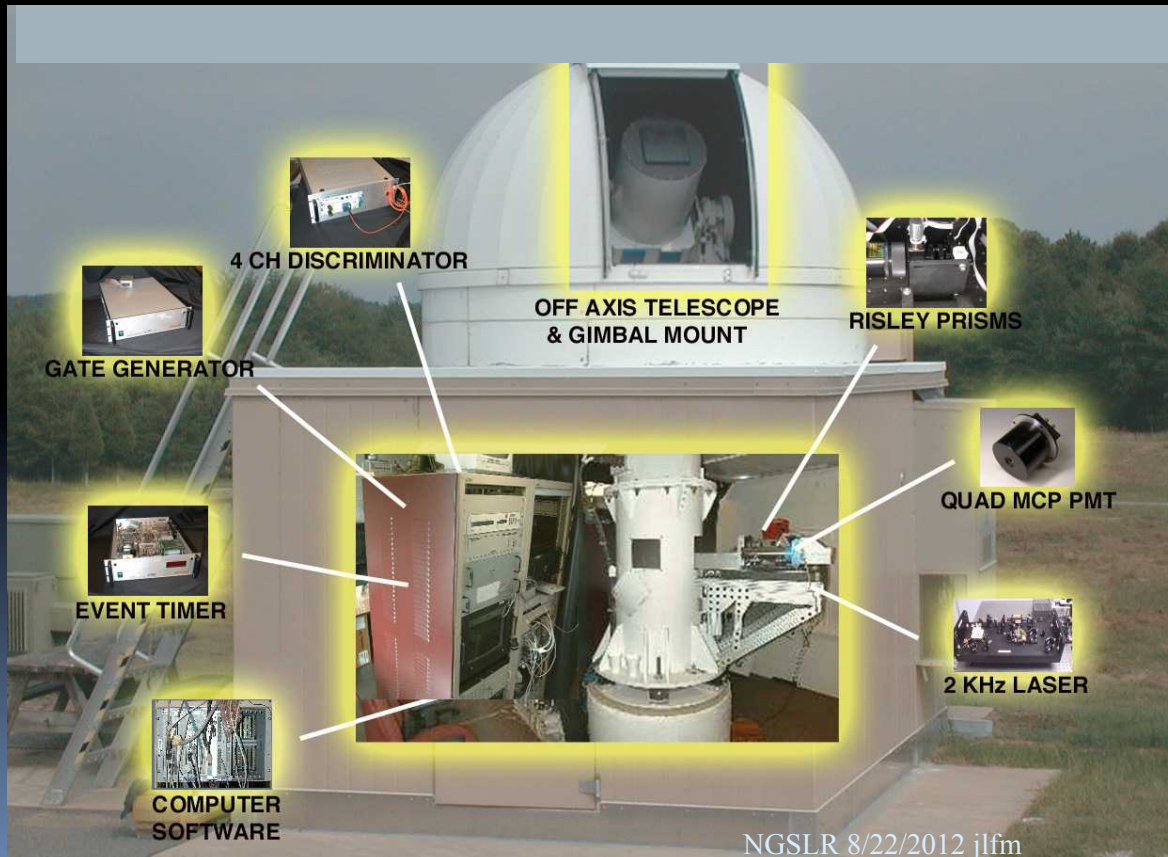

# NGSLR System Characteristics

- **Telescope:**
  - 40 cm Telescope Aperture Off-Axis Parabola
  - No Central Obscuration
- **Tracking:**
  - AZ/EL with 1 arcsec RMS gimbal pointing accuracy
- **Transceiver Bench:**
  - Common Optics for Transmit and Receive
  - Passive Transmit/Receive Switch
  - Risyey Prism Point-Ahead of Transmit
- **Laser (new):**
  - 50 ps pulsewidth, 2 kHz PRF, 3 mJ/pulse
  - Asynchronous PRF, software controlled
  - Divergence control by software
- **Receiver:**
  - High QE, GaAsP Microchannel Plate Photomultiplier
  - Constant Fraction Discriminators
  - GPS-synchronized Rubidium Oscillator /Time and Frequency Receiver
  - Picosecond Precision Event Timer
- **Weather:**
  - Day/Night All-Sky Cloud Sensor (thermal)
  - Wind Monitor
  - Surface Pressure, Temperature, and Humidity Monitors
  - Visibility/Precipitation Sensor

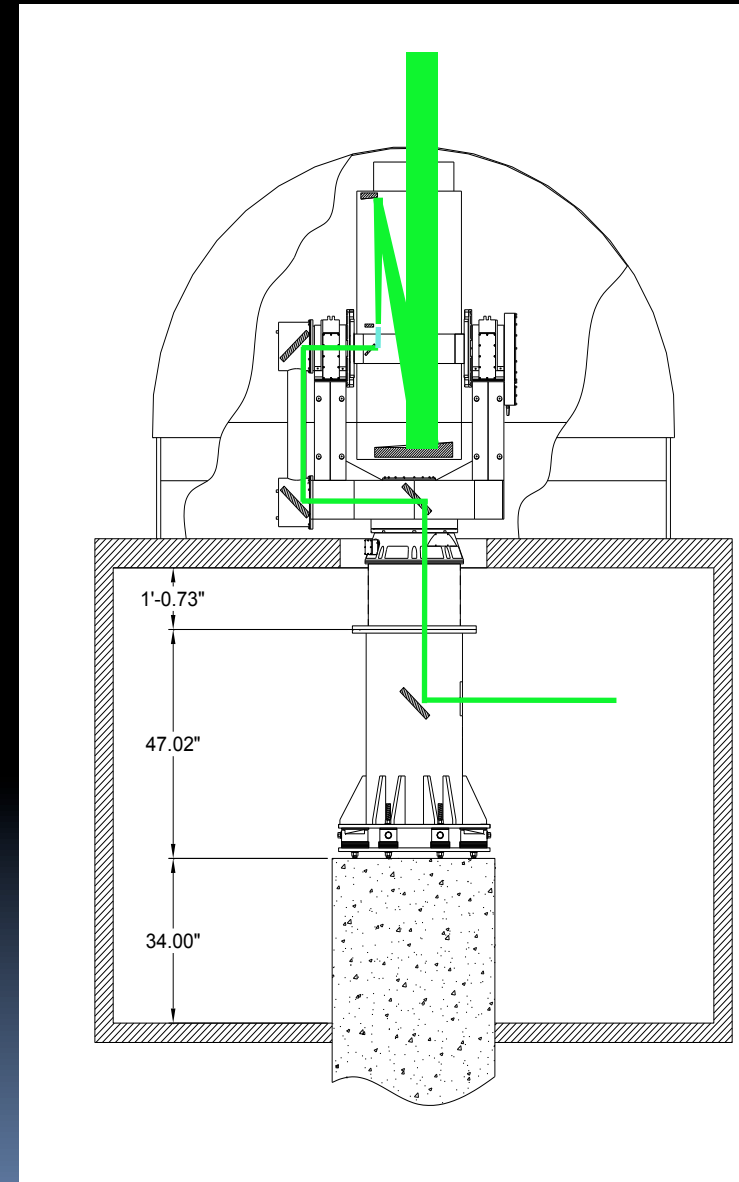

# New Technologies Developed for NGSLR

The requirements of SLR2000 (i.e. eye safety and unmanned operation) led to a number of unique computer-controlled hardware devices including:

- **Totally Passive Transmit/Receive Switch** allows the full aperture of the telescope to be shared simultaneously, with minimal optical loss, by the transmitter and receiver independent of the laser repetition rate and receive signal polarization.
- **Dual Risley Prism Device** permits independent arcsecond accuracy pointing of the transmitter and receiver allowing smaller receiver fields-of view for reduced solar noise.
- **Variable Laser Trigger** varies laser repetition rate about the nominal 2 kHz to prevent backscatter from the outgoing laser pulse from overlapping satellite returns at receiver.
- **Smart Meteorological Station** monitors hemispherical cloud cover and ground visibility, precipitation, wind speed and direction, while providing the usual atmospheric surface pressure, temperature, and relative humidity measurements needed to support atmospheric refraction corrections to the range measurements.

# NGSLR System Block Diagram

## Simplified Hardware Block Diagram

This diagram shows the basic flow of signals within the system.

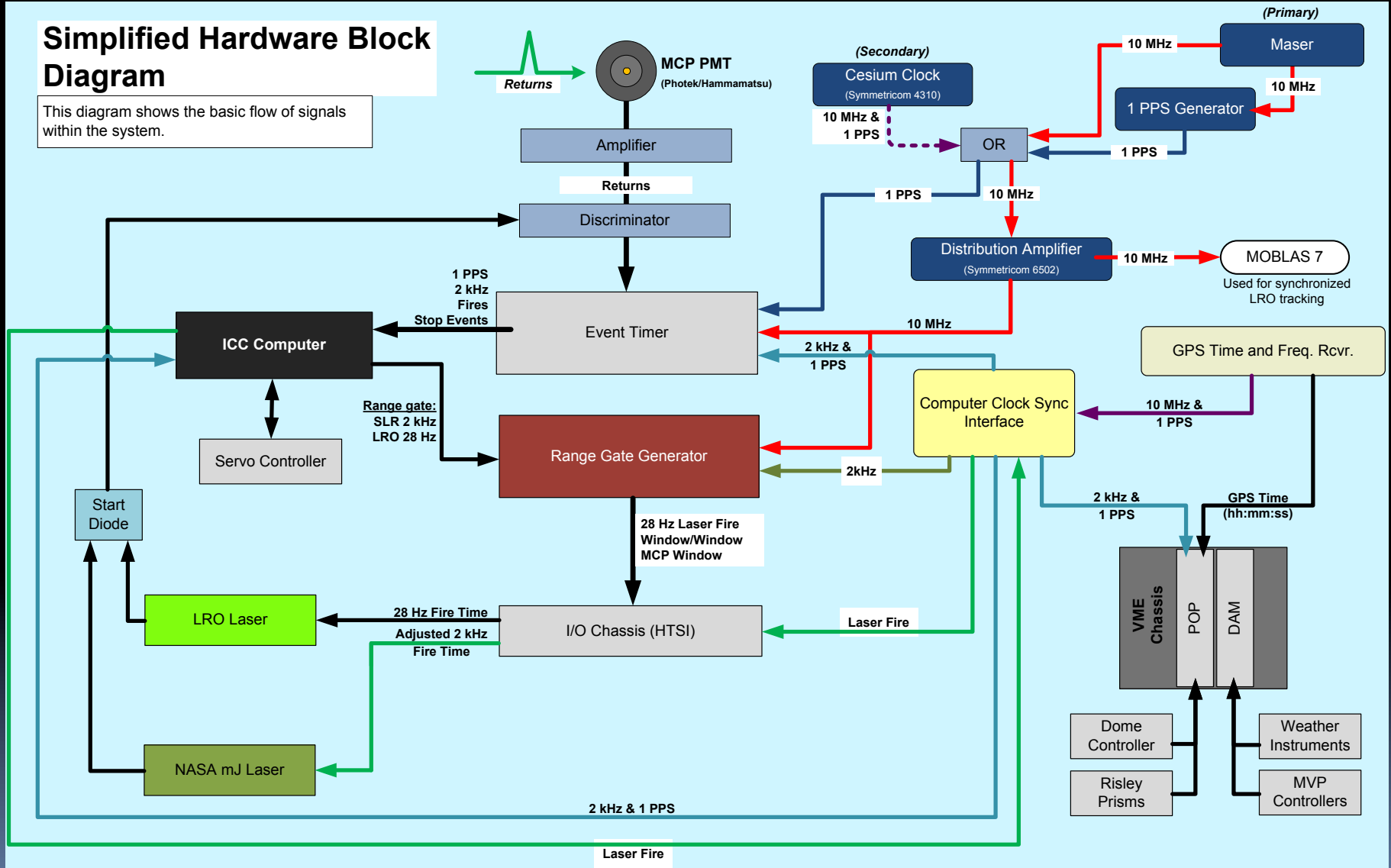

# Automation Overview

(some of the functions performed by the software)

- **Obtaining input files:**
  - automatically pull prediction and other data files from the server.
- **System scheduling:**
  - software completely determines/controls what is tracked and when.
- **Operator decision making:**
  - open/close dome based on weather,
  - keep telescope from pointing into the sun,
  - determine if we can track and where in the sky based on cloud cover.
- **Signal processing and closed-loop tracking:**
  - determine if system is hitting the satellite,
  - search for the satellite and optimize the pointing.
- **Transmit / receive path optics configuration and control:**
  - determine and control optical bench configuration,
  - decide configuration based on target, day/night.
- **Data processing and product delivery:** normal points delivered hourly.

# In-house built 2 kHz mJ laser

Regenerative amplifier seeded by a gain-switched diode laser

Used for intercomparison passes with MOB-7

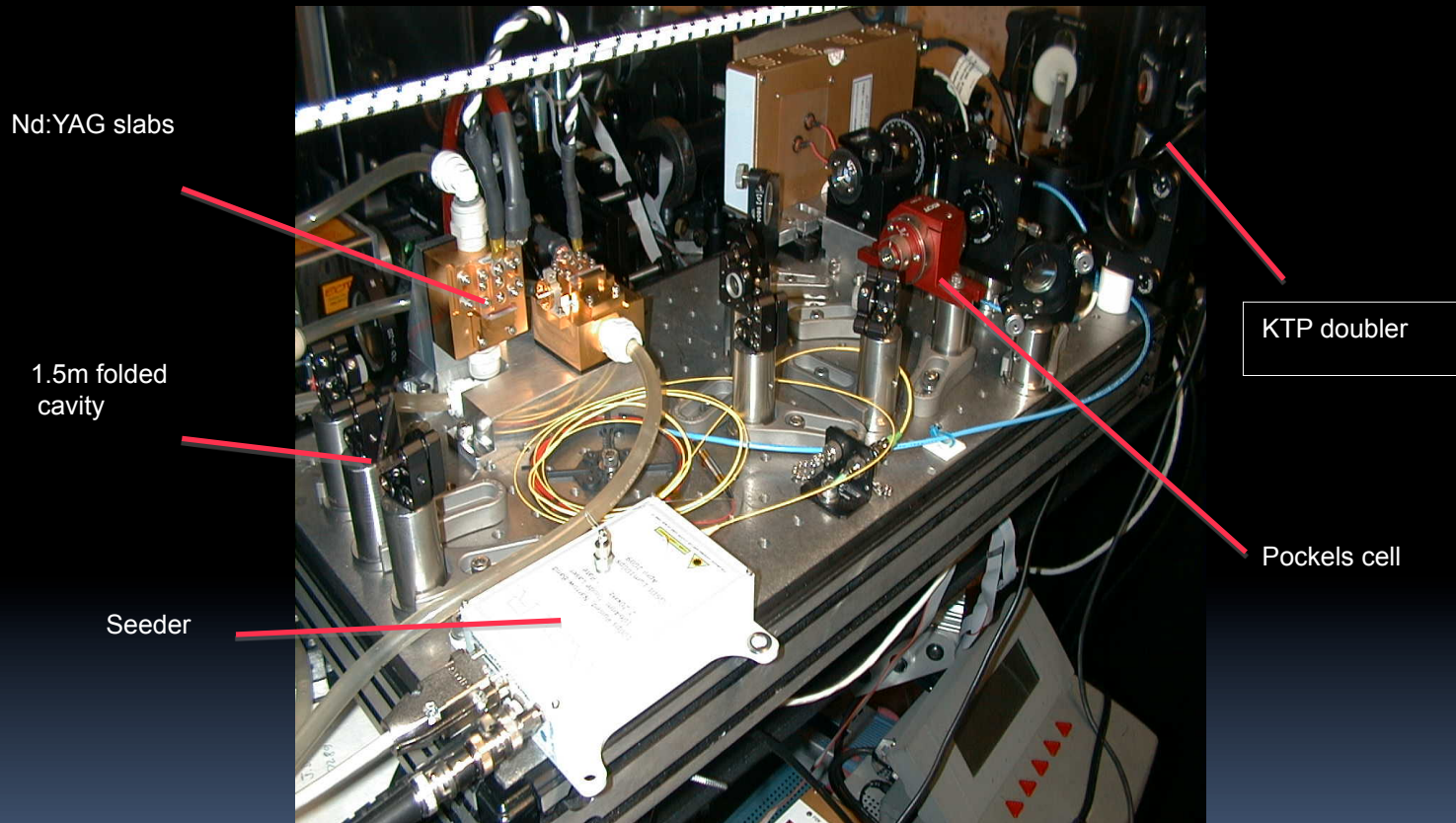

$\sim 200$  ps pulsewidth,  $\sim 1$  mJ per pulse energy

D. Poullos and B.Coyle



# SATELLITE PASSES TRACKED BY NGSLR APRIL TO JUNE 2012 SUBSET SELECTED FOR PRELIMINARY PERFORMANCE ANALYSIS

| SATELLITE              | # passes NIGHT | # passes DAY |
|------------------------|----------------|--------------|
| GLONASS (GNSS)         | 5              | 1            |
| GALILEO (GNSS)         | 1              | 0            |
| ETALON (GNSS altitude) | 1              | 0            |
| LAGEOS (1/2)           | 7              | 5            |
| LARES                  | 4              | 1            |
| STARLETTE/STELLA       | 4              | 5            |
| Other LEO              | 17             | 6            |
|                        |                |              |
| TOTAL                  | 39             | 18           |
|                        |                |              |

Passes tracked with Coyle laser and Hamamatsu detector

# Daylight Ranging to GNSS Observed Minus Calculated (OMC)

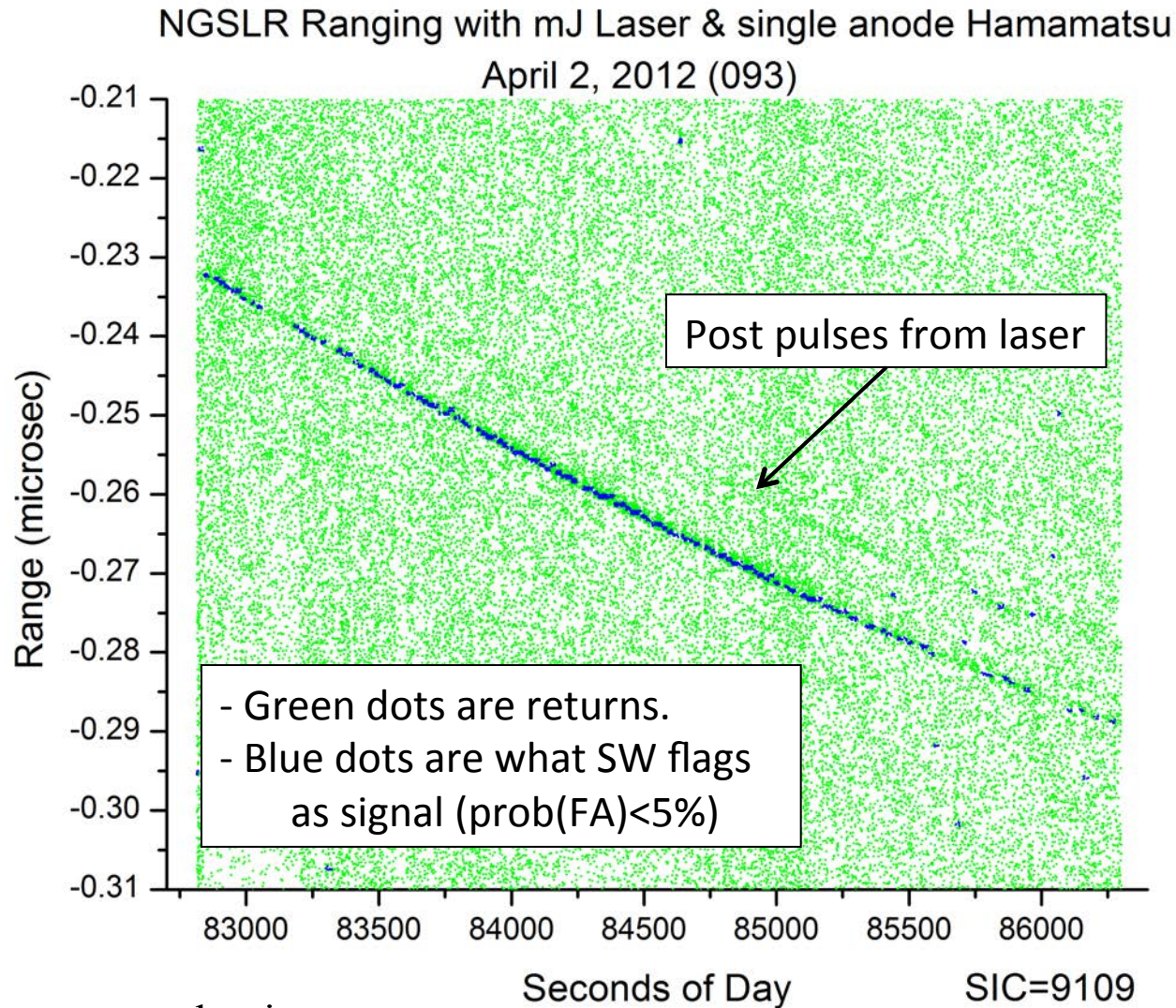

3 mm normal points

# Final System Configuration

## Hamamatsu High QE MCP PMT:

- Model R5916U-64
- GaAsP Photocathode
- QE > 43%
- Rise Time <178 ps
- Photocathode Input = 25mm  $\varnothing$



**In NGS LR now**

## Photonics Industries Short Pulse, Hi Energy, Hi Rep Rate Laser:

- Model RGL532-2.5
- Maximum Energy = 3 mJ
- Pulse Width FWHM = 50 ps
- Repetition Rate = Single Shot to 5 kHz
- Beam Divergence < 1 mR
- Output Beam Diameter = 1.7mm
- Spatial Mode Profile = TEM<sub>00</sub>
- Long Term Stability < +/- 2%
- Pulse to Pulse Stability < 2% RMS

**To be installed at NGS LR next week**



# New Optical Bench

## Reasons for new design:

- Improved alignment capability
- Space for automated controls
- Improved isolation between Xmit/Rcv

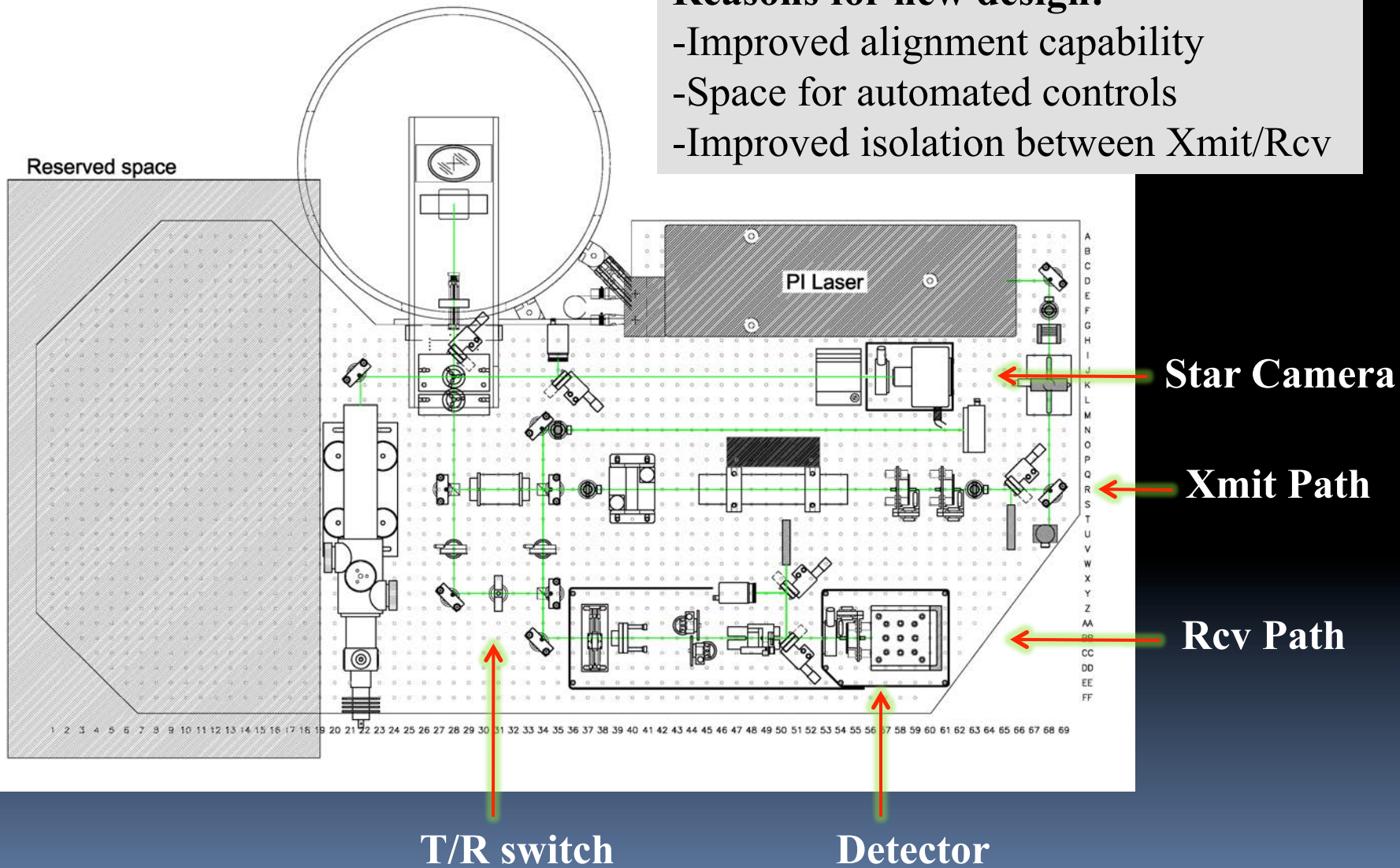

# Optical Bench Development in B33 Clean-room: completed

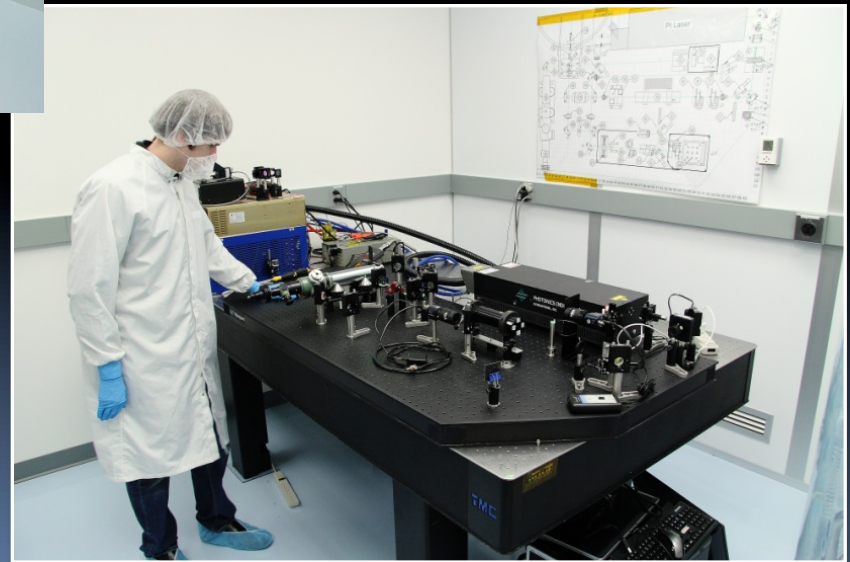
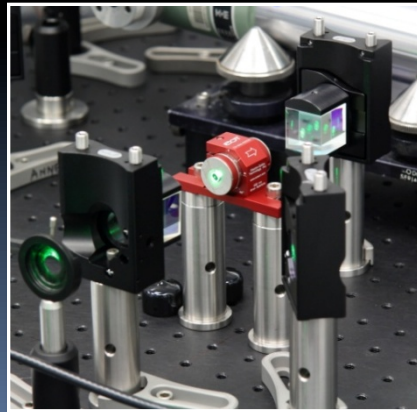
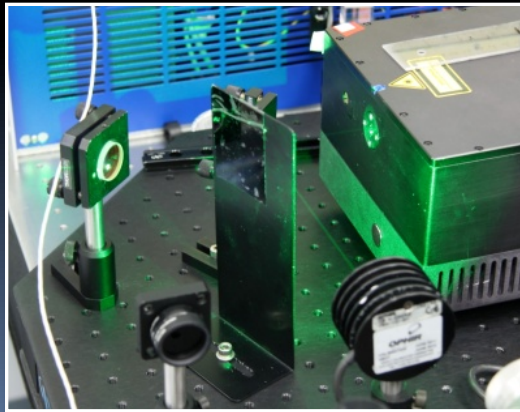
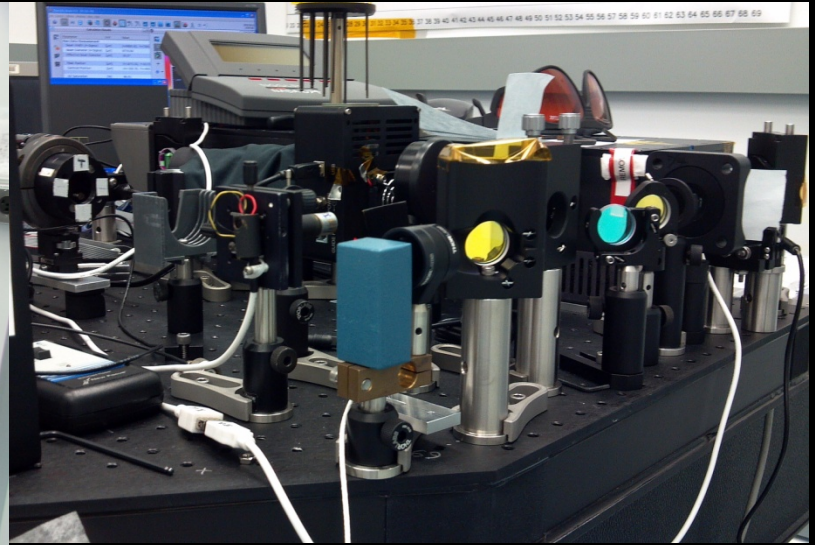
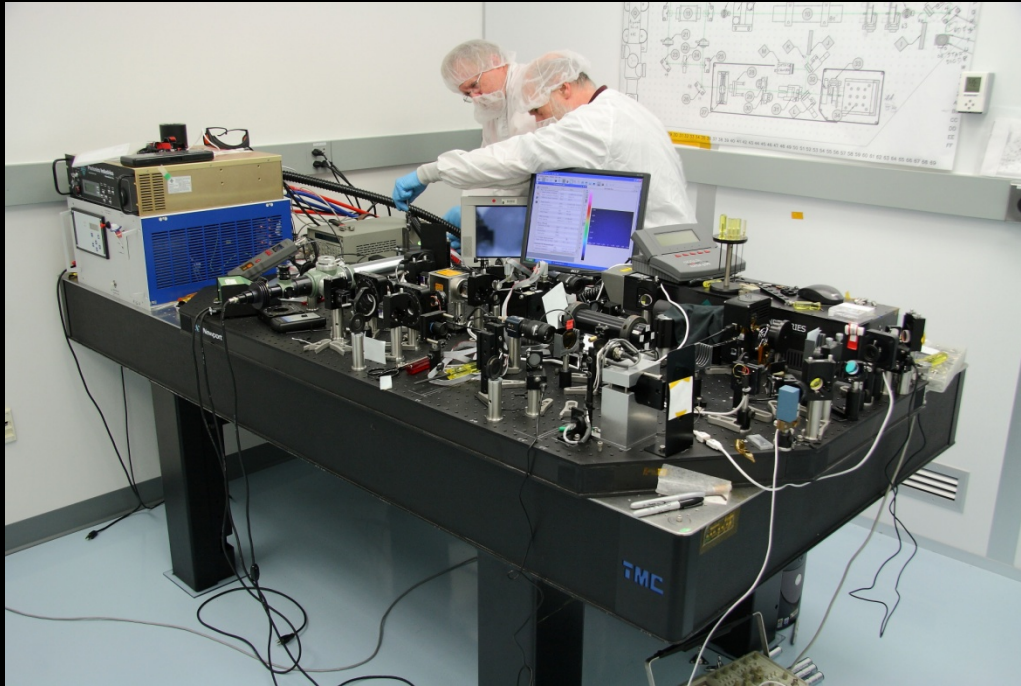

# Automation Testing at 1.2m Telescope Lab: close to complete

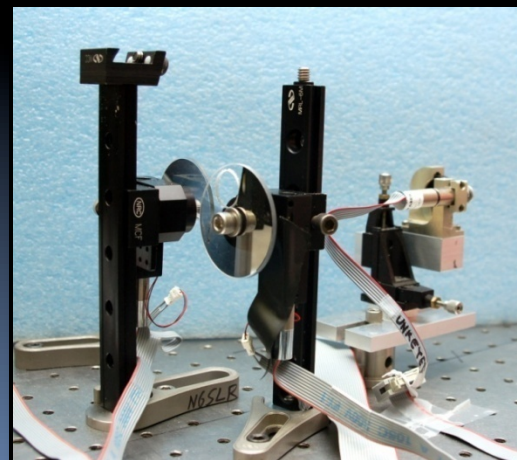
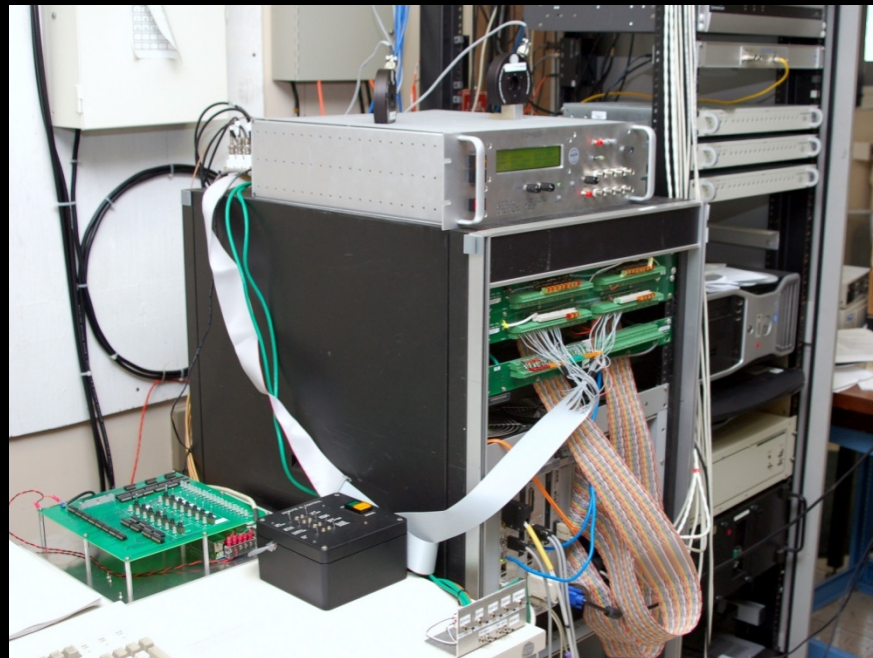
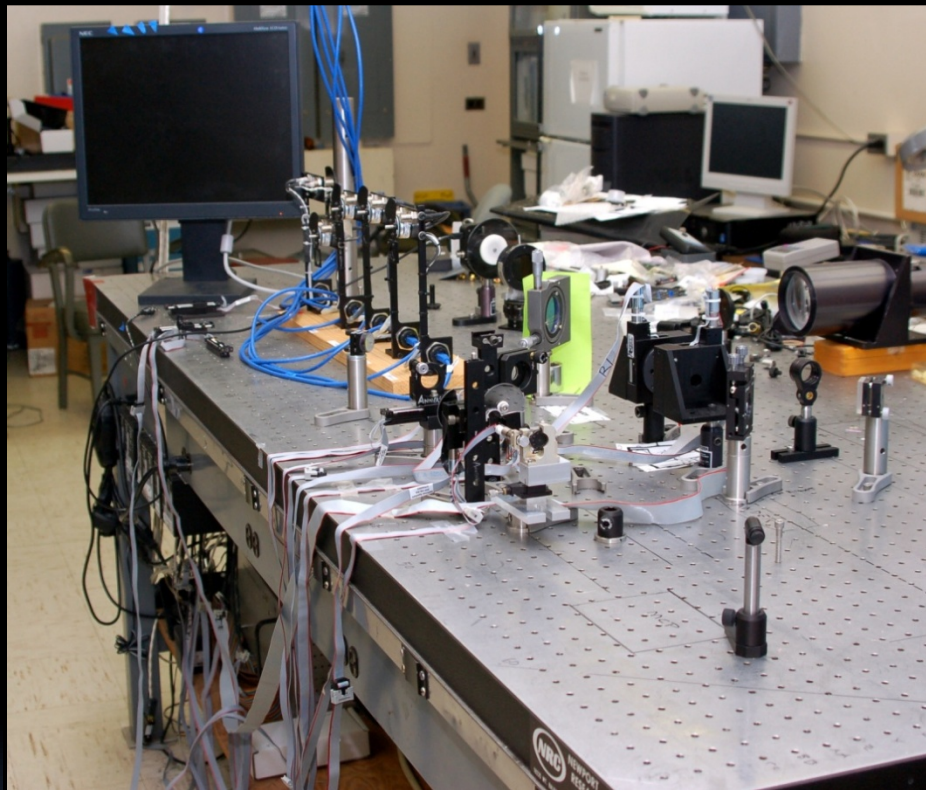

# SUMMARY

- GGAO is the birthplace of SLR. NASA has had an active SLR program at NASA since the 1964.
- Current NASA stations were built in the late 1970s and need to be replaced.
- One of the goals of the Space Geodesy Project is to get the prototype stations completed and to demonstrate performance.
- The Next Generation SLR (NGSLR) has demonstrated tracking of LEO to GNSS day and night (from altitudes of 300 km to 22000+ km).
- Preliminary tracking data being analyzed for performance.
- The automation and performance of NGSLR with new laser and optical bench will be demonstrated in the coming months.



NGSLR ranging to LRO

